

■ GENERAL DESCRIPTION

The NJM1496 is a double balanced modulator-demodulator which produces an output voltage proportional to the product of an input (signal) voltage and a switching (carrier) signal. Typical applications include suppressed carrier modulation, amplitude modulation, synchronous detection, FM or PM detection, broadband frequency doubling and chopping.

■ FEATURES

- Excellent carrier suppression
65dB typical at 0.5MHz
50 dB typical at 10MHz
- Adjustable gain and signal handling
- Fully balanced inputs and outputs
- High Common Mode Rejection 85dB Typ.
- Package Outline DIP14, DMP14, SSOP14
- Bipolar Technology

■ APPLICATION

- Balanced Modulation
- Synchronous Detection
- FM Detection
- Phase Detection
- Sampling

■ PIN CONFIGURATION

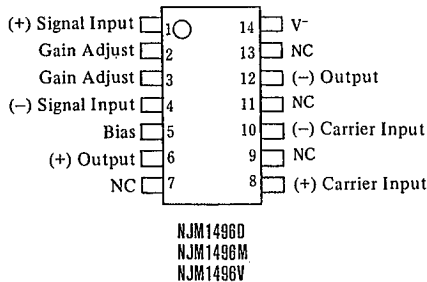

■ PACKAGE OUTLINE

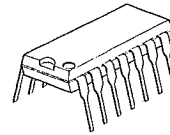

NJM1496D

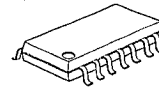

NJM1496M



NJM1496V

■ EQUIVALENT CIRCUIT

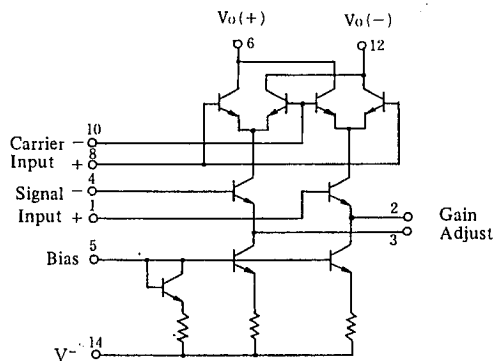

■ ABSOLUTE MAXIMUM RATINGS

(Ta=25°C)

PARAMETER	RATINGS	UNIT
Applied Voltage	30(Applied Pins 6-8, 12-8, 6-10, 12-10, 10-1, 8-1, 10-4, 8-4, 2-5, 3-5)	V
Carrier Input Voltage	±5(Applied Pins 8-10)	V
Signal Input Voltage	±(5+I _e Re) (Applied Pins 1-4)	V
Input Signal	5	V
Bias Current (I _s)	10	mA
Power Dissipation	(DIP14) 570	mW
	(DMP14) 300	mW
	(SSOP14) 300	mW
Operating Temperature Range	-20~+75	°C
Storage Temperature Range	-40~+125	°C

■ ELECTRICAL CHARACTERISTICS

DC Characteristics (V⁺=12V, V⁻=-8V, I_s=1.0mA, R_L=3.9kΩ, R_e=1.0kΩ, Ta=25°C)

PARAMETER	SYMBOL	TEST CONDITION	MIN.	TYP.	MAX.	UNIT
Single-Ended Input Impedance						
Parallel Input Resistance	R _{ip}	Signal Port, f=5.0MHz	—	200	—	kΩ
Parallel Input Capacitance	C _{ip}	Signal Port, f=5.0MHz	—	2.0	—	pF
Single-Ended Output Impedance						
Parallel Output Resistance	R _{op}	f=10MHz	—	40	—	kΩ
Parallel Output Capacitance	C _{op}	f=10MHz	—	5.0	—	pF
Input Bias Current						
I _{bs} = I ₁ + I ₄ /2	I _{bs}		—	12	30	μA
I _{bc} = I ₈ + I ₁₀ /2	I _{bc}		—	12	30	μA
Input Offset Current						
I _{ios} = I ₁ - I ₄	I _{ios}		—	0.7	7	μA
I _{ioc} = I ₈ - I ₁₀	I _{ioc}		—	0.7	7	μA
Average Temperature Coefficient of Input Offset Current	ΔI _{ios}		—	2.0	—	nA/°C
Output Offset Current (I _o - I ₁₂)	I _{oc}		—	15	80	μA
Average Temperature Coefficient of Output Offset Current	ΔI _{oc}		—	90	—	nA/°C
Output Voltage	V _o		—	8.0	—	V
Operating Current						
(I _o + I ₁₂)	I _{D+}		—	2.0	4.0	mA
I ₁₄	I _{D-}		—	3.0	5.0	mA
DC Power Dissipation	P _D		—	33	—	mW

■ **ELECTRICAL CHARACTERISTICS** AC Characteristics ($V^+=12V$, $V^-=-8V$, $I_S=1.0mA$, $R_L=2.9k\Omega$, $R_e=1.0k\Omega$, $T_a=25^\circ C$)

PARAMETER	SYMBOL	TEST CONDITION	MIN.	TYP.	MAX.	UNIT	
Carrier Feedthrough	V_{CFR}	$V_c = 60mV_{rms}$ sine wave offset adjusted	—	40	—	μV_{rms}	
		$f_c = 1.0kHz$	—	140	—	μV_{rms}	
	V_{CFR}	$V_c = 300mV_{p-p}$ square wave $f_c = 1.0kHz$	—	0.04	0.4	mV_{rms}	
		offset adjusted	—	20	200	mV_{rms}	
	Carrier Suppression	V_{CS}	$f_s = 10kHz$, $300mV_{rms}$ sine wave offset adjusted	40	65	—	dB
			$f_c = 500kHz$, $60mV_{rms}$ sine wave	—	50	—	dB
$f_c = 10MHz$, $60mV_{rms}$ sine wave			—	—	—	—	—
Transadmittance Bandwidth ($R_L = 50\Omega$)		$V_c = 60mV_{rms}$ sine wave					
Carrier Input Port	BW 3dB	$f_s = 1.0kHz$, $300mV_{rms}$ sine wave	—	300	—	MHz	
Signal Input Port	BW 3dB	$V_s = 300mV_{rms}$ sine wave $ V_c = 5V_{dc}$	—	80	—	MHz	
Voltage Gain, Signal Channel	AV_S	$V_s = 100mV_{rms}$ $f_s = 1.0kHz$ $ V_c = 0.5V_{dc}$	2.5	3.5	—	V/V	
Signal Port Common Mode Input Voltage Range	CM_V	$f_s = 1.0kHz$	—	5.0	—	V_{p-p}	
Signal Port Common Mode Rejection Ratio	ACM	$f_s = 1.0kHz$, $ V_c = 0.5V_{dc}$	—	-85	—	dB	
Differential Output Swing Capability	DV_{out}		—	8.0	—	V_{p-p}	

■ **TEST CIRCUIT**

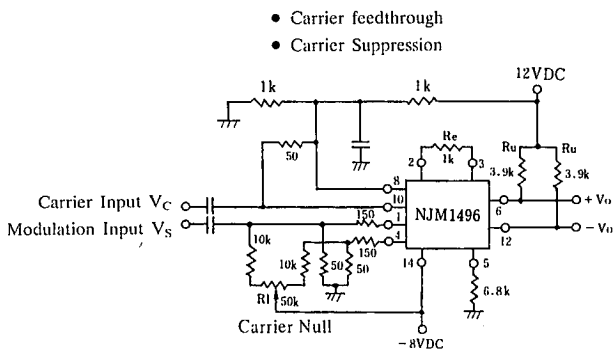

- Differential Output Swing Capability
- Signal Port Common Mode Rejection Ratio

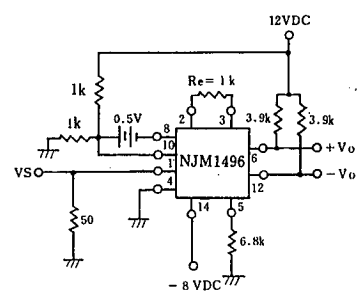

Connect a $100\mu F$ capacitor and a $3000pF$ capacitor in parallel to each other, if the capacitance is not specified.

■ TYPICAL CHARACTERISTICS

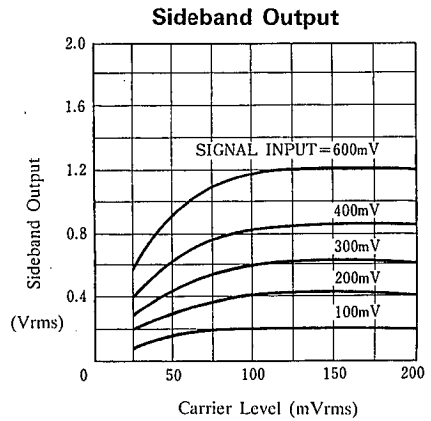
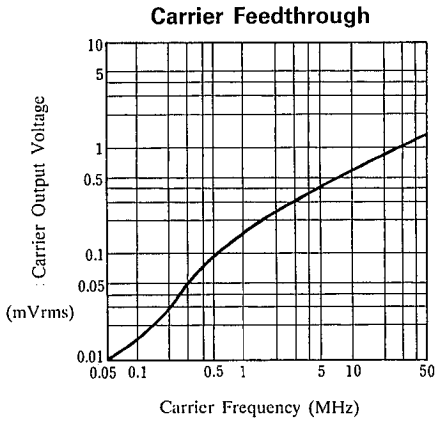
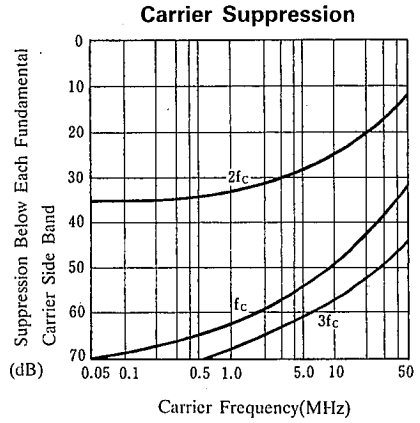
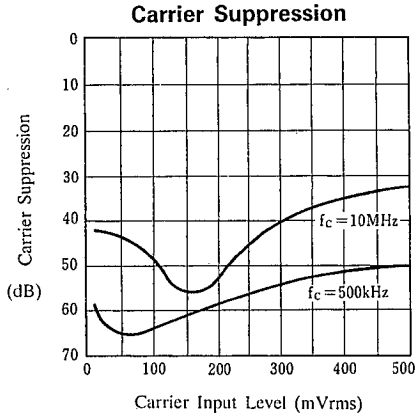

4

■ TYPICAL APPLICATIONS

AM Modulator Circuit

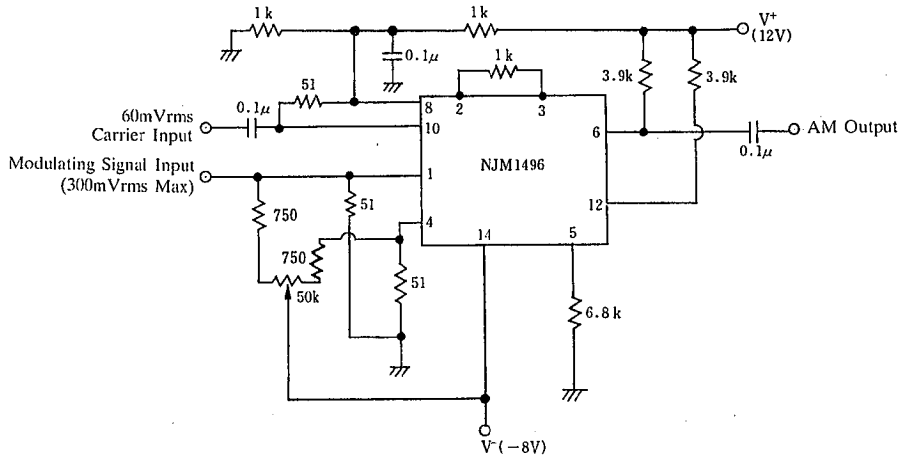

Product Detector (+12V DC Single Supply)

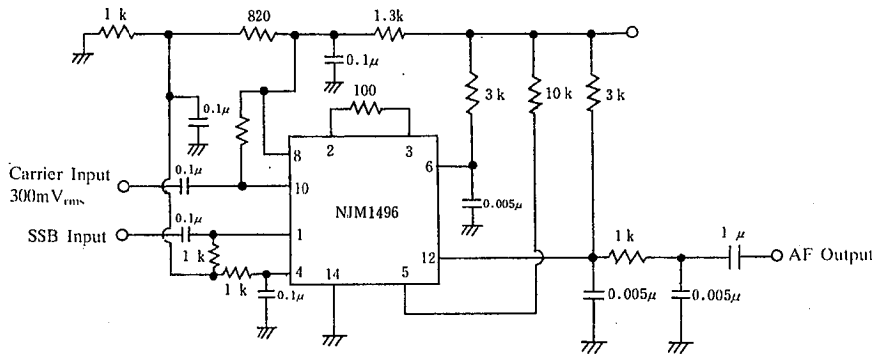

4

MEMO

[CAUTION]

The specifications on this databook are only given for information, without any guarantee as regards either mistakes or omissions. The application circuits in this databook are described only to show representative usages of the product and not intended for the guarantee or permission of any right including the industrial rights.