HD74AC74

Dual D-Type Positive Edge-Triggered Flip-Flop

HITACHI

Description

The HD74AC74 is a dual D-type flip-flop with Asynchronous Clear and Set inputs and complementary (Q, \bar{Q}) outputs. Information at the input is transferred to the outputs on the positive edge of the clock pulse. Clock triggering occurs at a voltage level of the clock pulse and is not directly related to the transition time of the positive-going pulse. After the Clock Pulse input threshold voltage has been passed, the Data input is locked out and information present will not be transferred to the outputs until the next rising edge of the Clock Pulse input.

Features

Asynchronous Inputs:

- Low input to \bar{S}_D (Set) sets Q to High level
 - Low input to \bar{C}_D (Clear) sets Q to Low level
 - Clear and Set are independent of clock
 - Simultaneous Low on \bar{C}_D and \bar{S}_D makes both Q and \bar{Q} High
- Outputs Source/Sink 24 mA

HD74AC74

Pin Arrangement

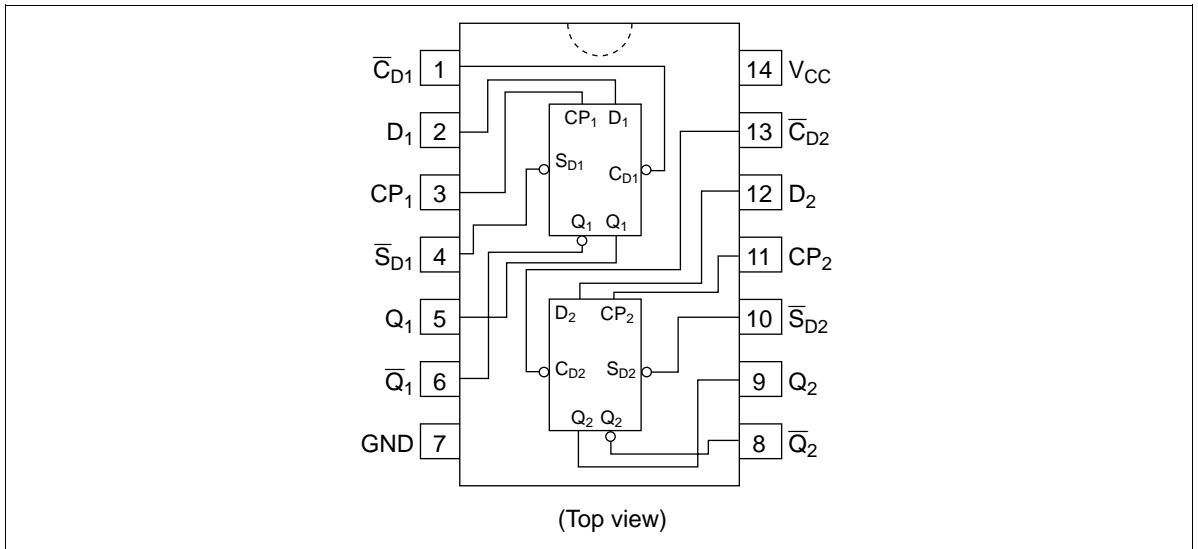

Logic Symbol

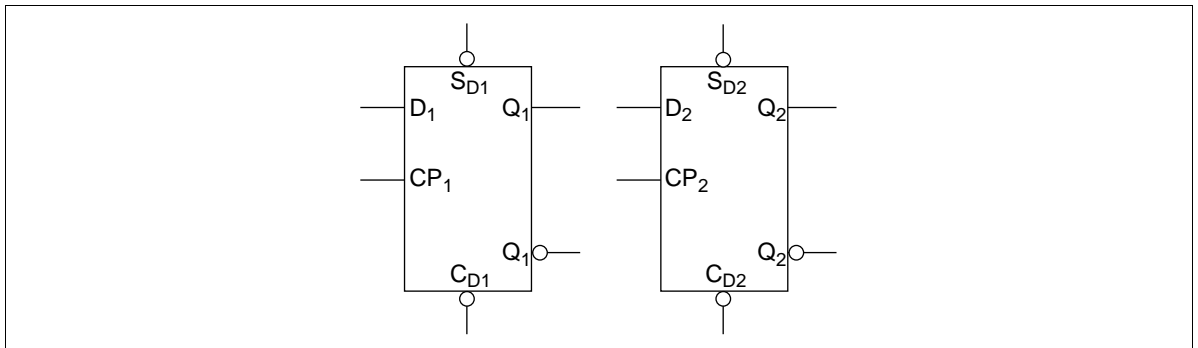

Pin Names

- D_1, D_2 Data Inputs
- CP_1, CP_2 Clock Pulse Inputs
- $\bar{C}_{D1}, \bar{C}_{D2}$ Direct Clear Inputs
- $\bar{S}_{D1}, \bar{S}_{D2}$ Direct Set Inputs
- $Q_1, \bar{Q}_1, Q_2, \bar{Q}_2$ Outputs

Truth Table (Each Half)

Inputs				Outputs	
\overline{S}_D	\overline{C}_D	CP	D	Q	\overline{Q}
L	H	X	X	H	L
H	L	X	X	L	H
L	L	X	X	H	H
H	H	\lrcorner	H	H	L
H	H	\lrcorner	L	L	H
H	H	L	X	Q ₀	\overline{Q}_0

H : High Voltage Level

L : Low Voltage Level

X : Immaterial

\lrcorner : Low-to-High Clock Transition

Q₀ (\overline{Q}_0) : Previous Q (\overline{Q}) before Low-to-High Transition of Clock

Logic Diagram

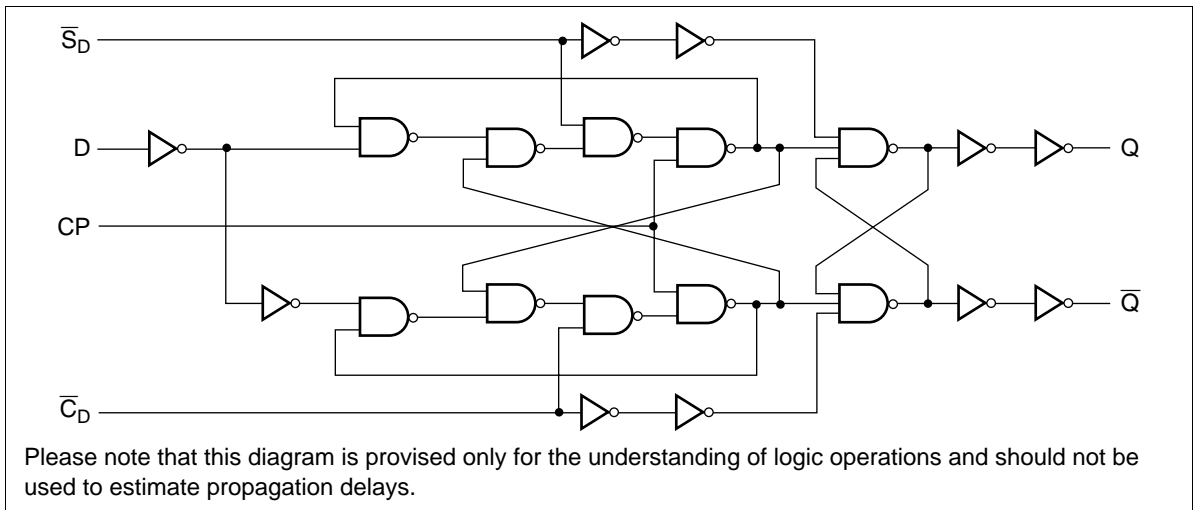

DC Characteristics (unless otherwise specified)

Item	Symbol	Max	Unit	Condition
Maximum quiescent supply current	I _{CC}	40	μA	V _{IN} = V _{CC} or ground, V _{CC} = 5.5 V, Ta = Worst case
Maximum quiescent supply current	I _{CC}	4.0	μA	V _{IN} = V _{CC} or ground, V _{CC} = 5.5 V, Ta = 25°C

HD74AC74

AC Characteristics

Item	Symbol	V _{CC} (V)*1	Ta = +25°C C _L = 50 pF			Ta = -40°C to +85°C C _L = 50 pF		Unit
			Min	Typ	Max	Min	Max	
Maximum clock frequency	f _{max}	3.3	100	125	—	95	—	MHz
		5.0	140	160	—	125	—	
Propagation delay C _{Dn} or S _{Dn} to Q _n or Q _n	t _{PLH}	3.3	1.0	8.0	12.0	1.0	13.0	ns
		5.0	1.0	6.0	9.0	1.0	10.0	
Propagation delay C _{Dn} or S _{Dn} to Q _n or Q _n	t _{PHL}	3.3	1.0	10.5	12.0	1.0	13.5	ns
		5.0	1.0	8.0	9.5	1.0	10.5	
Propagation delay CP _n to Q _n or Q _n	t _{PLH}	3.3	1.0	8.0	13.5	1.0	16.0	ns
		5.0	1.0	6.0	10.0	1.0	10.5	
Propagation delay CP _n to Q _n or Q _n	t _{PHL}	3.3	1.0	8.0	14.0	1.0	14.5	ns
		5.0	1.0	6.0	10.0	1.0	10.5	

Note: 1. Voltage Range 3.3 is 3.3 V ± 0.3 V
Voltage Range 5.0 is 5.0 V ± 0.5 V

AC Operating Requirements: HD74AC74

Item	Symbol	V _{CC} (V)*1	Ta = +25°C C _L = 50 pF		Ta = -40°C to +85°C C _L = 50 pF		Unit
			Typ	Guaranteed Minimum	Guaranteed Minimum	Guaranteed Minimum	
Set-up time, HIGH or LOW D _n to CP _n	t _{su}	3.3	1.5	4.0	4.5	ns	
		5.0	1.0	3.0	3.0		
Hold time, HIGH or LOW D _n to CP _n	t _h	3.3	-2.0	0	0	ns	
		5.0	-1.5	0	0		
Pulse width CP _n or C _{Dn} or S _{Dn}	t _w	3.3	3.0	5.5	7.0	ns	
		5.0	2.5	4.5	5.0		
Recovery time C _{Dn} or S _{Dn} to CP	t _{rec}	3.3	-2.5	0	0	ns	
		5.0	-2.0	0	0		

Note: 1. Voltage Range 3.3 is 3.3 V ± 0.3 V
Voltage Range 5.0 is 5.0 V ± 0.5 V

Capacitance

Item	Symbol	Typ	Unit	Condition
Input capacitance	C_{IN}	4.5	pF	$V_{CC} = 5.5 \text{ V}$
Power dissipation capacitance	C_{PD}	35.0	pF	$V_{CC} = 5.0 \text{ V}$

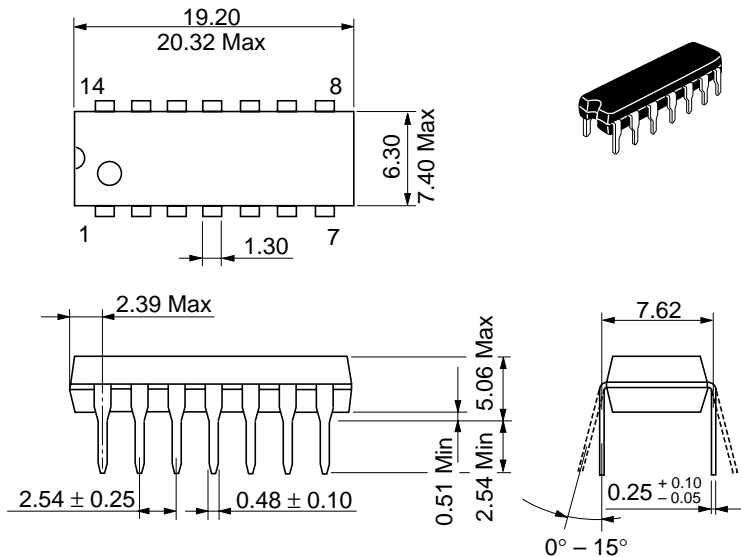

Hitachi Code	DP-14
JEDEC	Conforms
EIAJ	Conforms
Weight (reference value)	0.97 g

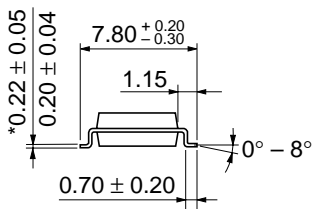
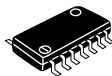
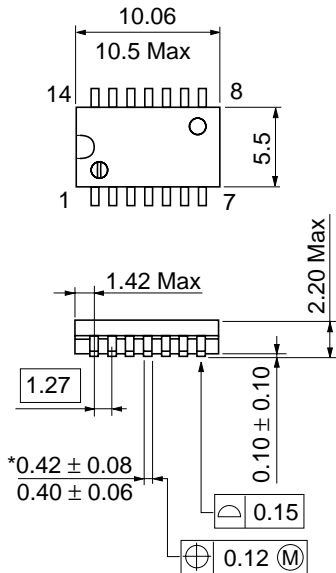

Hitachi Code	FP-14DA
JEDEC	—
EIAJ	Conforms
Weight (reference value)	0.23 g

*Dimension including the plating thickness
Base material dimension

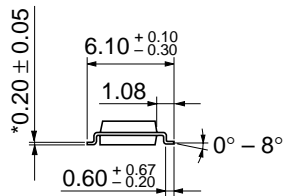
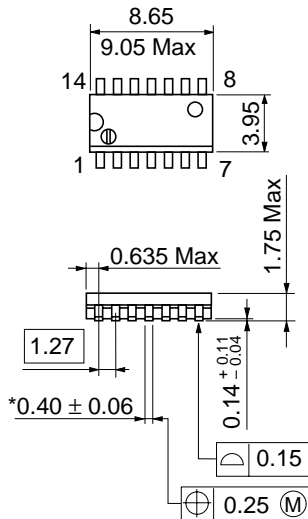

Hitachi Code	FP-14DN
JEDEC	Conforms
EIAJ	Conforms
Weight (reference value)	0.13 g

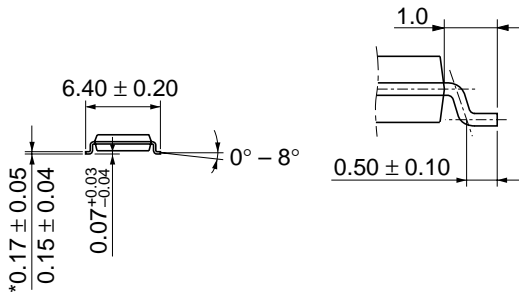
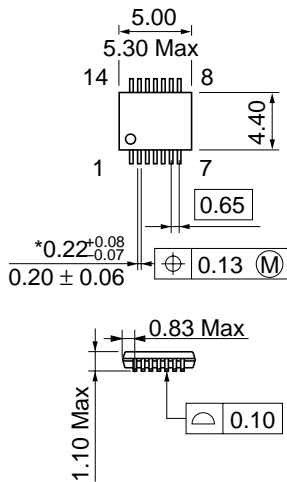

*Dimension including the plating thickness
 Base material dimension

Hitachi Code	TTP-14D
JEDEC	—
EIAJ	—
Weight (reference value)	0.05 g

Cautions

1. Hitachi neither warrants nor grants licenses of any rights of Hitachi's or any third party's patent, copyright, trademark, or other intellectual property rights for information contained in this document. Hitachi bears no responsibility for problems that may arise with third party's rights, including intellectual property rights, in connection with use of the information contained in this document.
2. Products and product specifications may be subject to change without notice. Confirm that you have received the latest product standards or specifications before final design, purchase or use.
3. Hitachi makes every attempt to ensure that its products are of high quality and reliability. However, contact Hitachi's sales office before using the product in an application that demands especially high quality and reliability or where its failure or malfunction may directly threaten human life or cause risk of bodily injury, such as aerospace, aeronautics, nuclear power, combustion control, transportation, traffic, safety equipment or medical equipment for life support.
4. Design your application so that the product is used within the ranges guaranteed by Hitachi particularly for maximum rating, operating supply voltage range, heat radiation characteristics, installation conditions and other characteristics. Hitachi bears no responsibility for failure or damage when used beyond the guaranteed ranges. Even within the guaranteed ranges, consider normally foreseeable failure rates or failure modes in semiconductor devices and employ systemic measures such as fail-safes, so that the equipment incorporating Hitachi product does not cause bodily injury, fire or other consequential damage due to operation of the Hitachi product.
5. This product is not designed to be radiation resistant.
6. No one is permitted to reproduce or duplicate, in any form, the whole or part of this document without written approval from Hitachi.
7. Contact Hitachi's sales office for any questions regarding this document or Hitachi semiconductor products.

HITACHI

Hitachi, Ltd.

Semiconductor & Integrated Circuits.
Nippon Bldg., 2-6-2, Ohte-machi, Chiyoda-ku, Tokyo 100-0004, Japan
Tel: Tokyo (03) 3270-2111 Fax: (03) 3270-5109

URL North America : <http://semiconductor.hitachi.com/>
 Europe : <http://www.hitachi-eu.com/hel/ecg>
 Asia (Singapore) : <http://www.has.hitachi.com.sg/grp3/sicd/index.htm>
 Asia (Taiwan) : http://www.hitachi.com.tw/E/Product/SICD_Frame.htm
 Asia (HongKong) : <http://www.hitachi.com.hk/eng/bo/grp3/index.htm>
 Japan : <http://www.hitachi.co.jp/Sicd/indx.htm>

For further information write to:

Hitachi Semiconductor
(America) Inc.
179 East Tasman Drive,
San Jose, CA 95134
Tel: <1> (408) 433-1990
Fax: <1> (408) 433-0223

Hitachi Europe GmbH
Electronic components Group
Dornacher Straße 3
D-85622 Feldkirchen, Munich
Germany
Tel: <49> (89) 9 9180-0
Fax: <49> (89) 9 29 30 00

Hitachi Europe Ltd.
Electronic Components Group.
Whitebrook Park
Lower Cookham Road
Maidenhead
Berkshire SL6 8YA, United Kingdom
Tel: <44> (1628) 585000
Fax: <44> (1628) 778322

Hitachi Asia Pte. Ltd.
16 Collyer Quay #20-00
Hitachi Tower
Singapore 049318
Tel: 535-2100
Fax: 535-1533

Hitachi Asia Ltd.
Taipei Branch Office
3F, Hung Kuo Building, No.167,
Tun-Hwa North Road, Taipei (105)
Tel: <886> (2) 2718-3666
Fax: <886> (2) 2718-8180

Hitachi Asia (Hong Kong) Ltd.
Group III (Electronic Components)
7/F., North Tower, World Finance Centre,
Harbour City, Canton Road, Tsim Sha Tsui,
Kowloon, Hong Kong
Tel: <852> (2) 735 9218
Fax: <852> (2) 730 0281
Telex: 40815 HITEC HX

Copyright ' Hitachi, Ltd., 1999. All rights reserved. Printed in Japan.

HITACHI