

1/3-inch CCD Image Sensor for EIA B/W Camera

Description

The ICX054AL is an interline CCD solid-state image sensor suitable for EIA 1/3-inch B/W video cameras. High sensitivity is achieved through the adoption of HAD (Hole-Accumulation Diode) sensors.

This chip features a field period readout system, and an electronic shutter with variable charge-storage time.

Features

- High sensitivity (+3dB compare with ICX044BLA) and low dark current
- Continuous variable-speed shutter
1/60s (Typ.), 1/100s to 1/10000s
- Low smear
- Excellent antiblooming characteristics
- Horizontal register: 5V drive
- Reset gate: 5V drive

Device Structure

- Optical size: 1/3-inch format
- Number of effective pixels: 510 (H) x 492 (V) approx. 250K pixels
- Number of total pixels: 537 (H) x 505 (V) approx. 270K pixels
- Interline CCD image sensor
- Chip size: 6.00mm (H) x 4.96mm (V)
- Unit cell size: 9.6µm (H) x 7.5µm (V)
- Optical black:

Horizontal (H) direction:	Front 2 pixels, Rear 25 pixels
Vertical (V) direction:	Front 12 pixels, Rear 1 pixel
- Number of dummy bits:

Horizontal	16
Vertical	1 (even field only)
- Substrate material: Silicon

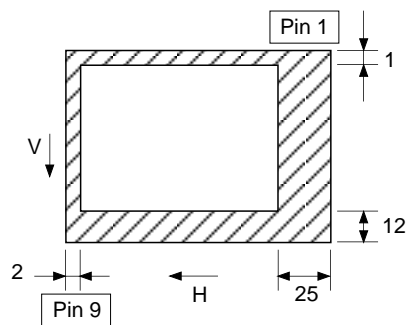
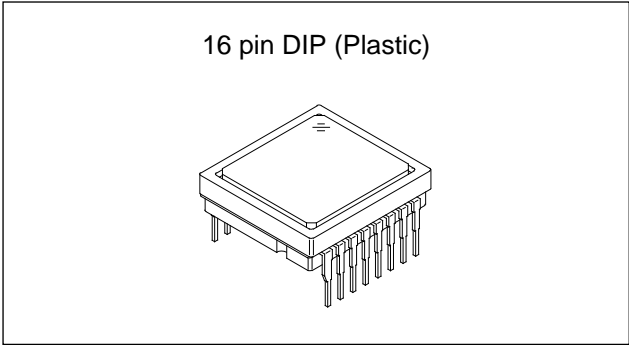

Optical black position
(Top View)

Sony reserves the right to change products and specifications without prior notice. This information does not convey any license by any implication or otherwise under any patents or other right. Application circuits shown, if any, are typical examples illustrating the operation of the devices. Sony cannot assume responsibility for any problems arising out of the use of these circuits.

Block Diagram and Pin Configuration

(Top View)

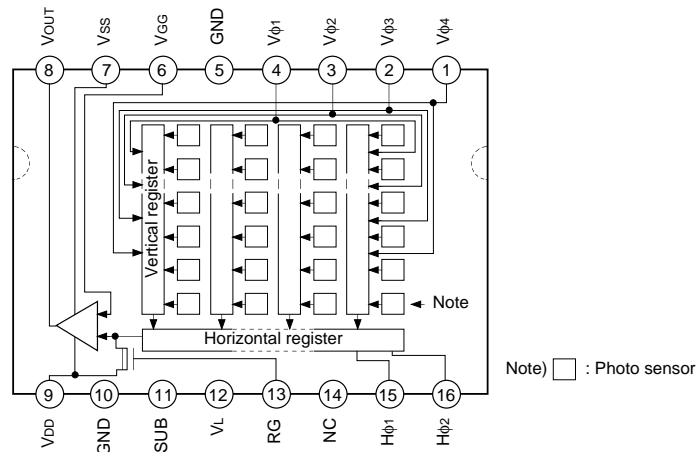

Pin Description

Pin No.	Symbol	Description	Pin No.	Symbol	Description
1	V ϕ ₄	Vertical register transfer clock	9	V _{DD}	Output amplifier drain supply
2	V ϕ ₃	Vertical register transfer clock	10	GND	GND
3	V ϕ ₂	Vertical register transfer clock	11	SUB	Substrate (Overflow drain)
4	V ϕ ₁	Vertical register transfer clock	12	V _L	Protective transistor bias
5	GND	GND	13	RG	Reset gate clock
6	V _{GG}	Output amplifier gate bias	14	NC	
7	V _{SS}	Output amplifier source	15	H ϕ ₁	Horizontal register transfer clock
8	V _{OUT}	Signal output	16	H ϕ ₂	Horizontal register transfer clock

Absolute Maximum Ratings

Item		Ratings	Unit	Remarks
Substrate voltage SUB – GND		-0.3 to +55	V	
Supply voltage	V _{DD} , V _{OUT} , V _{SS} – GND	-0.3 to +18	V	
	V _{DD} , V _{OUT} , V _{SS} – SUB	-55 to +10	V	
Vertical clock input voltage	V ϕ ₁ , V ϕ ₂ , V ϕ ₃ , V ϕ ₄ – GND	-15 to +20	V	
	V ϕ ₁ , V ϕ ₂ , V ϕ ₃ , V ϕ ₄ – SUB	to +10	V	
Voltage difference between vertical clock input pins		to +15	V	*1
Voltage difference between horizontal clock input pins		to +17	V	
H ϕ ₁ , H ϕ ₂ – V ϕ ₄		-17 to +17	V	
H ϕ ₁ , H ϕ ₂ , RG, V _{GG} – GND		-10 to +15	V	
H ϕ ₁ , H ϕ ₂ , RG, V _{GG} – SUB		-55 to +10	V	
V _L – SUB		-65 to +0.3	V	
V ϕ ₁ , V ϕ ₂ , V ϕ ₃ , V ϕ ₄ , V _{DD} , V _{OUT} – V _L		-0.3 to +30	V	
RG – V _L		-0.3 to +24	V	
V _{GG} , V _{SS} , H ϕ ₁ , H ϕ ₂ – V _L		-0.3 to +20	V	
Storage temperature		-30 to +80	°C	
Operating temperature		-10 to +60	°C	

*1 +27V (Max.) when clock width < 10 μ s, clock duty factor < 0.1%.

Clock Voltage Conditions

Item	Symbol	Min.	Typ.	Max.	Unit	Waveform diagram	Remarks
Readout clock voltage	V_{VT}	14.55	15.0	15.45	V	1	
Vertical transfer clock voltage	V_{VH1}, V_{VH2}	-0.05	0	0.05	V	2	$V_{VH} = (V_{VH1} + V_{VH2}) / 2$
	V_{VH3}, V_{VH4}	-0.2	0	0.05	V	2	
	$V_{VL1}, V_{VL2}, V_{VL3}, V_{VL4}$	-9.0	-8.5	-8.0	V	2	$V_{VL} = (V_{VL3} + V_{VL4}) / 2$
	$V_{\phi V}$	7.8	8.5	9.05	V	2	$V_{\phi V} = V_{VHn} - V_{VLn} (n = 1 \text{ to } 4)$
	$ V_{VH1} - V_{VH2} $			0.1	V	2	
	$V_{VH3} - V_{VH}$	-0.25		0.1	V	2	
	$V_{VH4} - V_{VH}$	-0.25		0.1	V	2	
	V_{VHH}			0.5	V	2	High-level coupling
	V_{VHL}			0.5	V	2	High-level coupling
	V_{VLH}			0.5	V	2	Low-level coupling
	V_{VLL}			0.5	V	2	Low-level coupling
Horizontal transfer clock voltage	$V_{\phi H}$	4.75	5.0	5.25	V	3	
	V_{HL}	-0.05	0	0.05	V	3	
Reset gate clock voltage	$V_{\phi RG}$	4.5	5.0	5.5	V	4	*1
	$V_{RGLH} - V_{RGLL}$			0.8	V	4	Low-level coupling
Substrate clock voltage	$V_{\phi SUB}$	22.5	23.5	24.5	V	5	

*1 The reset gate clock voltage need not be adjusted when reset gate clock is driven when the specifications are as given below. In this case, the reset gate clock voltage setting indicated on the back of the image sensor has not significance.

Item	Symbol	Min.	Typ.	Max.	Unit	Waveform diagram	Remarks
Reset gate clock voltage	V_{RGL}	-0.2	0	0.2	V	4	
	$V_{\phi RG}$	8.5	9.0	9.5	V	4	

Clock Equivalent Circuit Constant

Item	Symbol	Min.	Typ.	Max.	Unit	Remarks
Capacitance between vertical transfer clock and GND	$C\phi V1, C\phi V3$		1500		pF	
	$C\phi V2, C\phi V4$		820		pF	
Capacitance between vertical transfer clocks	$C\phi V12, C\phi V34$		470		pF	
	$C\phi V23, C\phi V41$		230		pF	
	$C\phi V13$		150		pF	
	$C\phi V24$		230		pF	
Capacitance between horizontal transfer clock and GND	$C\phi H1, C\phi H2$		47		pF	
Capacitance between horizontal transfer clocks	$C\phi HH$		47		pF	
Capacitance between reset gate clock and GND	$C\phi RG$		5		pF	
Capacitance between substrate clock and GND	$C\phi SUB$		320		pF	
Vertical transfer clock series resistor	$R1, R3$		51		Ω	
	$R2, R4$		100		Ω	
Vertical transfer clock ground resistor	R_{GND}		15		Ω	
Horizontal transfer clock series resistor	$R\phi H$		10		Ω	
Reset gate clock series resistor	$R\phi RG$		40		Ω	

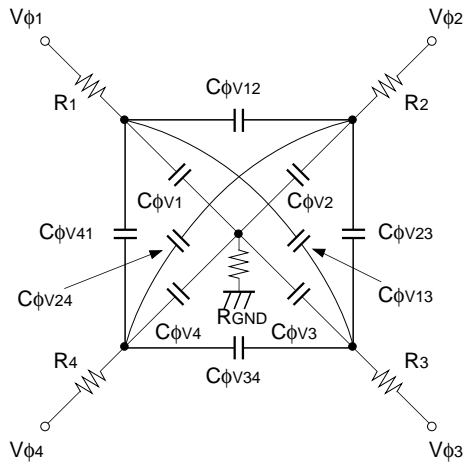

Vertical transfer clock equivalent circuit

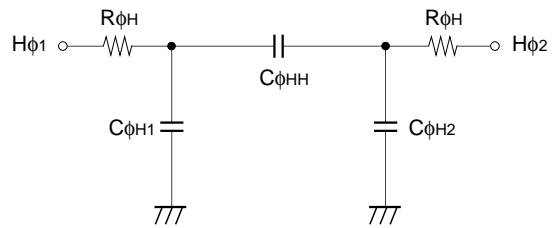

Horizontal transfer clock equivalent circuit

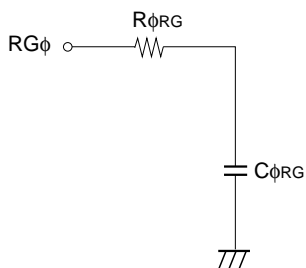

Reset gate clock equivalent circuit

Drive Clock Waveform Conditions

(1) Readout clock waveform

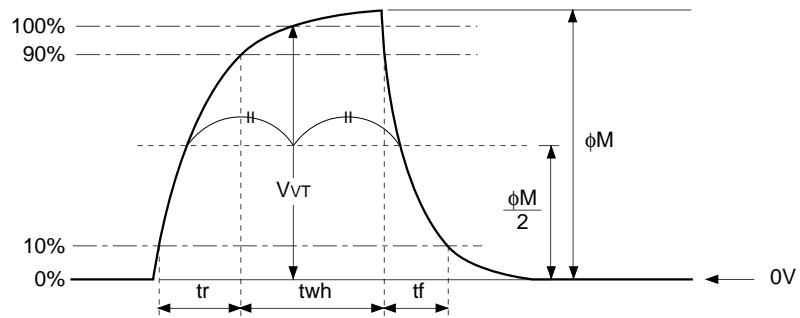

(2) Vertical transfer clock waveform

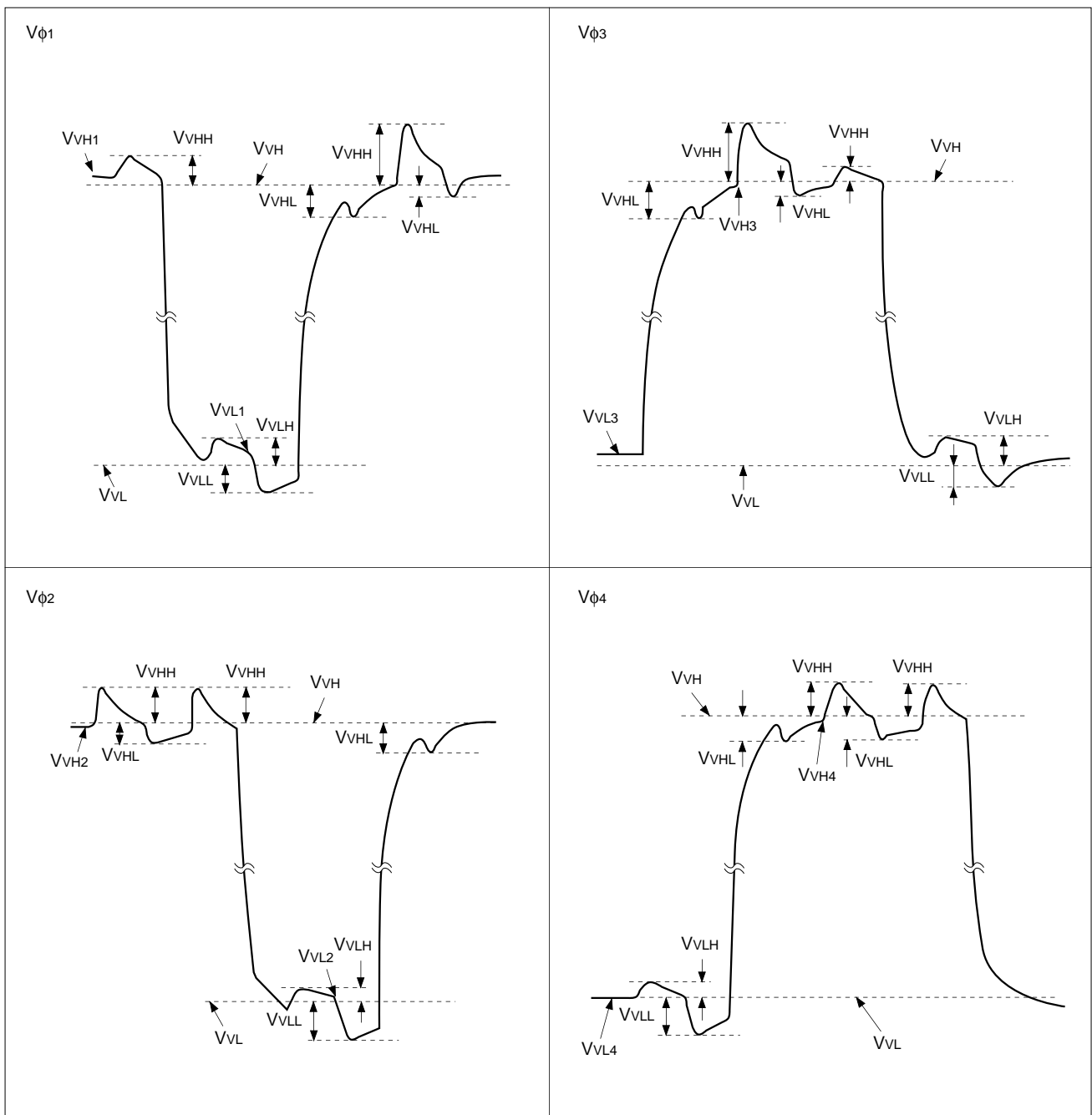

(3) Horizontal transfer clock waveform

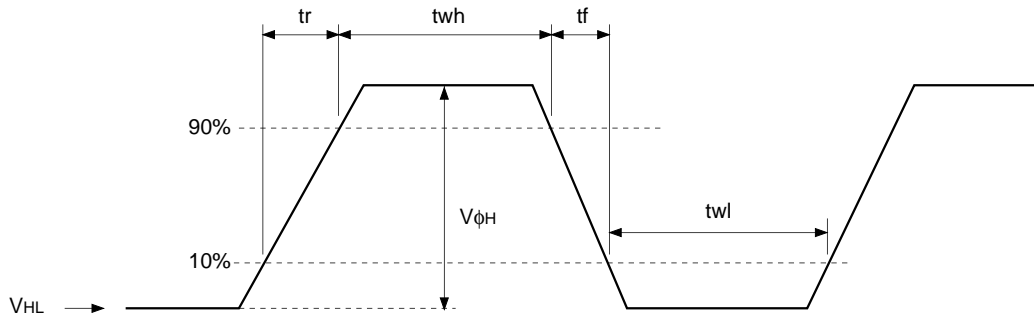

(4) Reset gate clock waveform

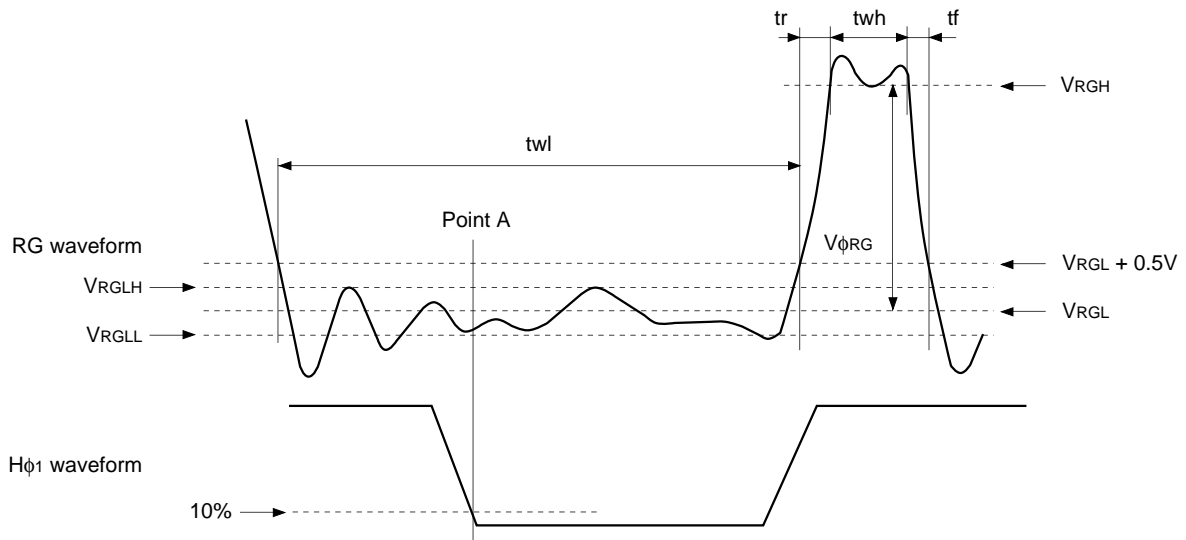

V_{RGLH} is the maximum value and V_{RGL} is the minimum value of the coupling waveform during the period from Point A in the above diagram until the rising edge of RG.

In addition, V_{RGL} is the average value of V_{RGLH} and V_{RGL} .

$$V_{RGL} = (V_{RGLH} + V_{RGL})/2$$

Assuming V_{RGH} is the minimum value during the interval t_{wh} , then:

$$V_{\phi RG} = V_{RGH} - V_{RGL}$$

(5) Substrate clock waveform

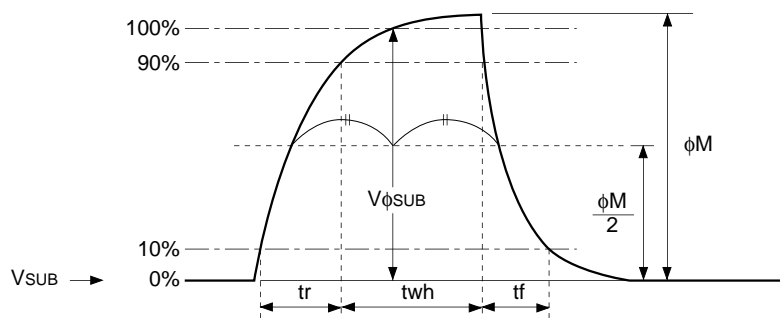

Clock Switching Characteristics

Item	Symbol	twh			twl			tr			tf			Unit	Remarks
		Min.	Typ.	Max.	Min.	Typ.	Max.	Min.	Typ.	Max.	Min.	Typ.	Max.		
Readout clock	V_T	2.3	2.5						0.5			0.5		μs	During readout
Vertical transfer clock	$V_{\phi_1}, V_{\phi_2}, V_{\phi_3}, V_{\phi_4}$										0.015		0.25	μs	*1
Horizontal transfer clock	H_{ϕ}	37	41		38	42			12	15	*2	10	15	ns	During imaging
Horizontal transfer clock	H_{ϕ_1}		5.6						0.012			0.012		μs	During parallel-serial conversion
Horizontal transfer clock	H_{ϕ_2}					5.6			0.012			0.012		μs	During parallel-serial conversion
Reset gate clock	ϕ_{RG}	11	15		75	79			6.5			4.5		ns	
Substrate clock	ϕ_{SUB}	1.5	2.0						0.5			0.5		μs	During drain charge

*1 When vertical transfer clock driver CXD1250 is used.

*2 $t_f \geq t_r - 2ns$

Image Sensor Characteristics

(Ta = 25°C)

Item	Symbol	Min.	Typ.	Max.	Unit	Measurement method	Remarks
Sensitivity	S	470	560		mV	1	
Saturation signal	Vsat	700			mV	2	Ta = 60°C
Smear	Sm		0.005	0.007	%	3	
Video signal shading	SH			20	%	4	Zone 0, I
				25	%	4	Zone 0 to II'
Dark signal	Vdt			2	mV	5	Ta = 60°C
Dark signal shading	ΔVdt			1	mV	6	Ta = 60°C
Flicker	F			2	%	7	
Lag	Lag			0.5	%	8	

Zone Definition of Video Signal Shading

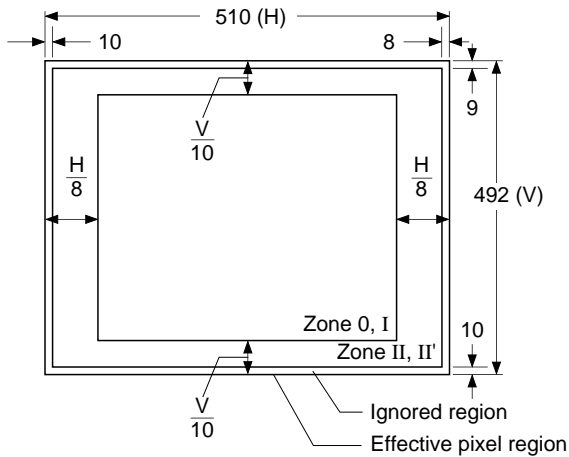

Image Sensor Characteristics Measurement Method

◎ Measurement conditions

- 1) In the following measurements, the substrate voltage and the reset gate clock voltage are set to the values indicated on the device, and the device drive conditions are at the typical values of the bias and clock voltage conditions.
- 2) In the following measurements, spot blemishes are excluded and, unless otherwise specified, the optical black (OB) level is used as the reference for the signal output, and the value measured at point [*A] in the drive circuit example is used.

◎ Definition of standard imaging conditions

- 1) Standard imaging condition I:
Use a pattern box (luminance 706cd/m², color temperature of 3200K halogen source) as a subject. (Pattern for evaluation is not applicable.) Use a testing standard lens with CM500S (t = 1.0mm) as an IR cut filter and image at F8. The luminous intensity to the sensor receiving surface at this point is defined as the standard sensitivity testing luminous intensity.
- 2) Standard imaging condition II:
Image a light source (color temperature of 3200K) with a uniformity of brightness within 2% at all angles. Use a testing standard lens with CM500S (t = 1.0mm) as an IR cut filter. The luminous intensity is adjusted to the value indicated in each testing item by the lens diaphragm.

1. Sensitivity

Set to standard imaging condition I. After selecting the electronic shutter mode with a shutter speed of 1/250s, measure the signal output (Vs) at the center of the screen and substitute the value into the following formula.

$$S = V_s \times \frac{250}{60} \text{ [mV]}$$

2. Saturation signal

Set to standard imaging condition II. After adjusting the luminous intensity to 10 times the intensity with average value of the signal output, 200mV, measure the minimum value of the signal output.

3. Smear

Set to standard imaging condition II. With the lens diaphragm at F5.6 to F8, adjust the luminous intensity to 500 times the intensity with average value of the signal output, 200mV. When the readout clock is stopped and the charge drain is executed by the electronic shutter at the respective H blankings, measure the maximum value VSm [mV] of the signal output and substitute the value into the following formula.

$$S_m = \frac{V_{Sm}}{200} \times \frac{1}{500} \times \frac{1}{10} \times 100 \text{ [%]} \text{ (1/10V method conversion value)}$$

4. Video signal shading

Set to standard imaging condition II. With the lens diaphragm at F5.6 to F8, adjust the luminous intensity so that the average value of the signal output is 200mV. Then measure the maximum (Vmax [mV]) and minimum (Vmin [mV]) values of the signal output and substitute the values into the following formula.

$$SH = (V_{max} - V_{min})/200 \times 100 \text{ [%]}$$

5. Dark signal

Measure the average value of the signal output (Vdt [mV]) with the device ambient temperature 60°C and the device in the light-obstructed state, using the horizontal idle transfer level as a reference.

6. Dark signal shading

After measuring 5, measure the maximum (Vdmax [mV]) and minimum (Vdmin [mV]) values of the dark signal output and substitute the values into the following formula.

$$\Delta V_{dt} = V_{dmax} - V_{dmin} \text{ [mV]}$$

7. Flicker

Set to standard imaging condition II. Adjust the luminous intensity so that the average value of the signal output is 200mV, and then measure the difference in the signal level between fields (ΔV_f [mV]). Then substitute the value into the following formula.

$$F = (\Delta V_f / 200) \times 100 \text{ [%]}$$

8. Lag

Adjust the signal output value generated by strobe light to 200mV. After setting the strobe light so that it strobes with the following timing, measure the residual signal (Vlag). Substitute the value into the following formula.

$$\text{Lag} = (V_{lag} / 200) \times 100 \text{ [%]}$$

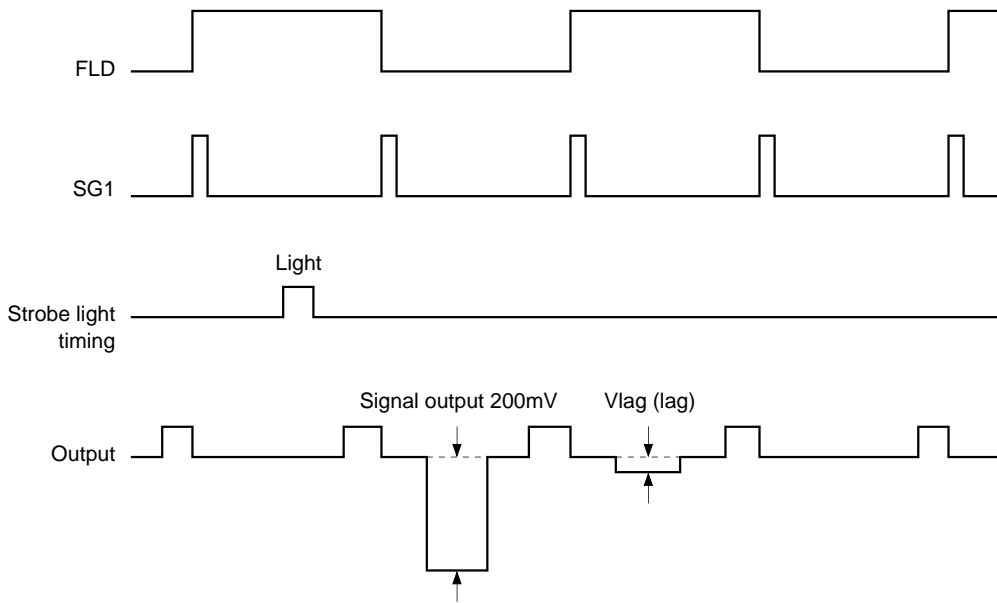

Drive Circuit

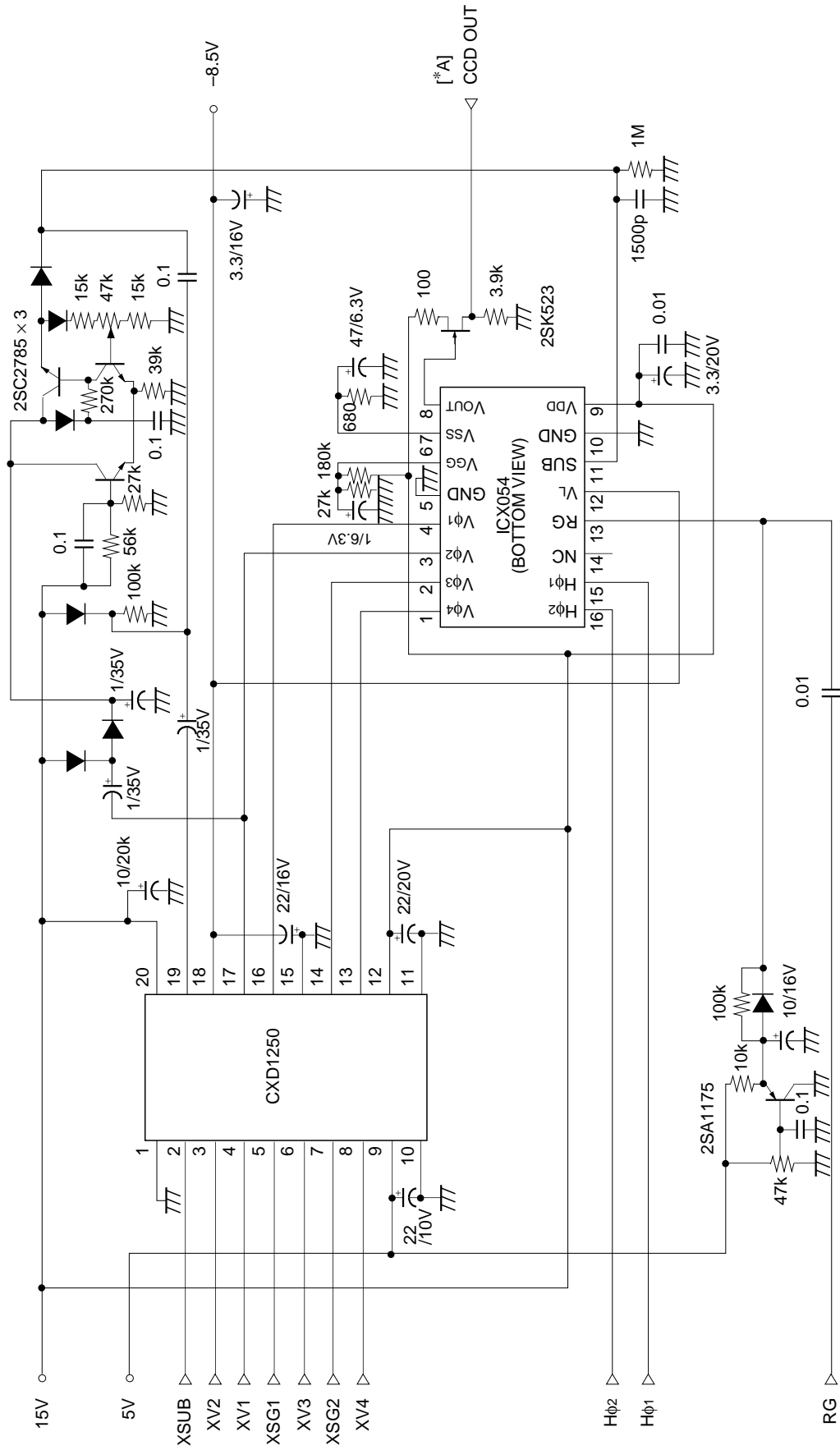

Spectral Sensitivity Characteristics

(Includes lens characteristics, excludes light source characteristics)

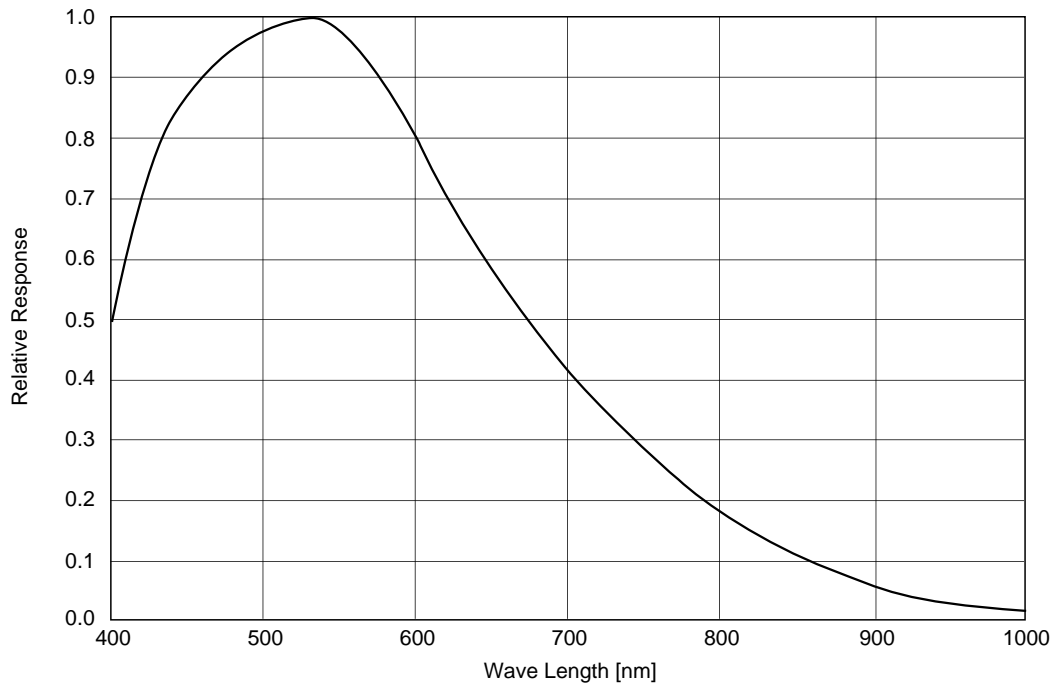

Sensor Readout Clock Timing Chart

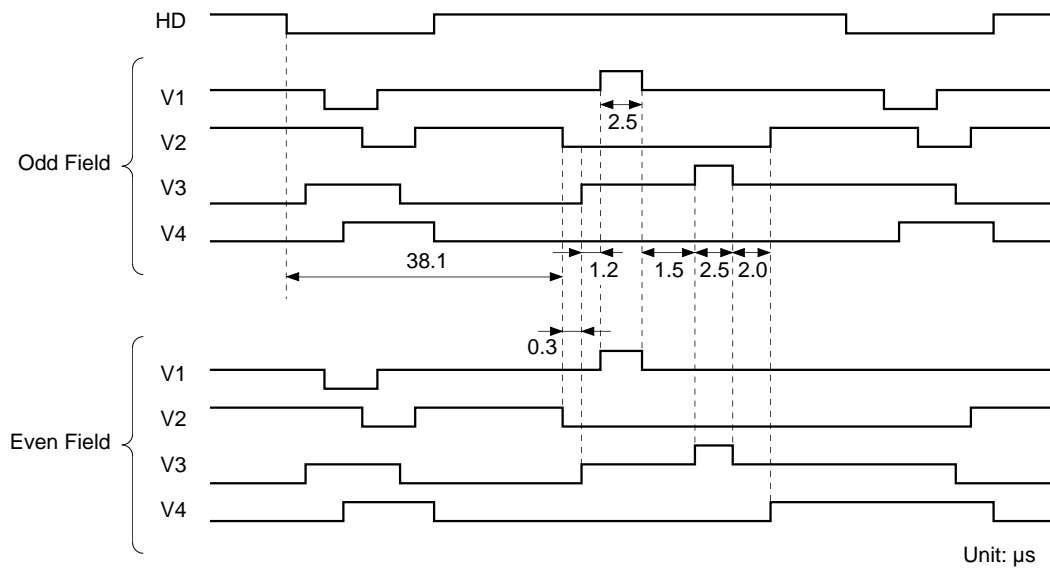

Drive Timing Chart (Vertical sync)

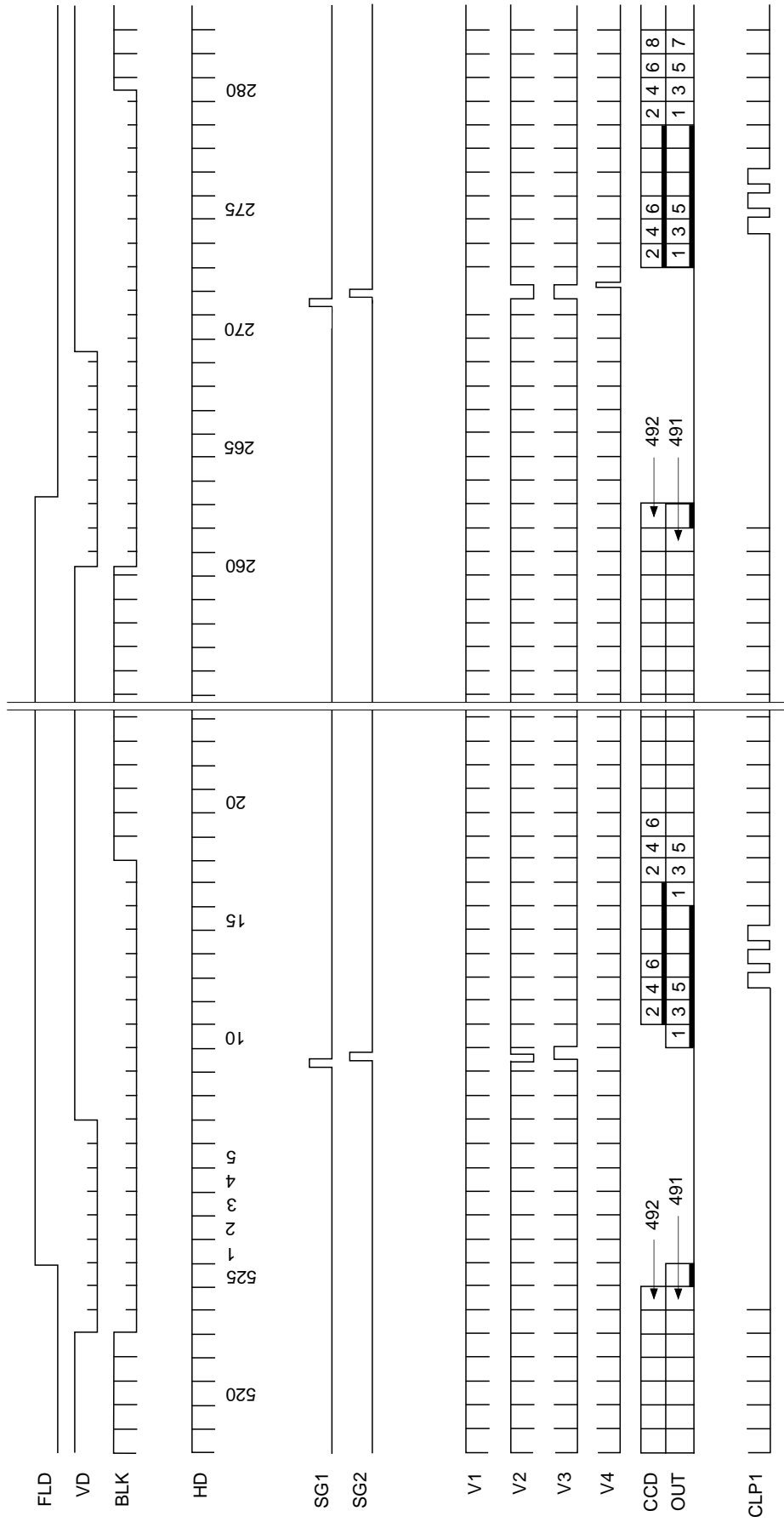

Drive Timing Chart (Horizontal sync)

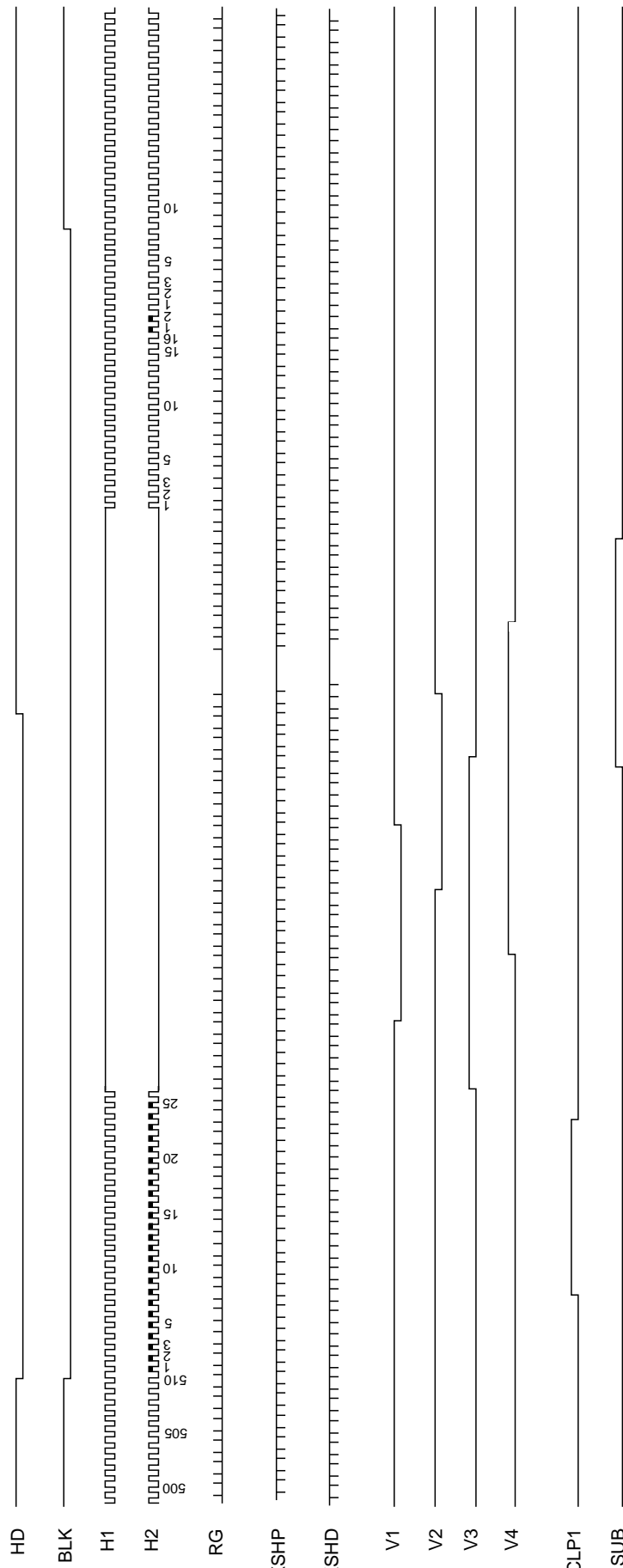

Notes on Handling

1) Static charge prevention

CCD image sensors are easily damaged by static discharge. Before handling be sure to take the following protective measures.

- a) Either handle bare handed or use non-chargeable gloves, clothes or material.
Also use conductive shoes.
- b) When handling directly use an earth band.
- c) Install a conductive mat on the floor or working table to prevent the generation of static electricity.
- d) Ionized air is recommended for discharge when handling CCD image sensor.
- e) For the shipment of mounted substrates, use boxes treated for the prevention of static charges.

2) Soldering

- a) Make sure the package temperature does not exceed 80°C.
- b) Solder dipping in a mounting furnace causes damage to the glass and other defects. Use a ground 30W soldering iron and solder each pin in less than 2 seconds. For repairs and remount, cool sufficiently.
- c) To dismount an image sensor, do not use a solder suction equipment. When using an electric desoldering tool, use a thermal controller of the zero cross On/Off type and connect it to ground.

3) Dust and dirt protection

- a) Operate in clean environments (around class 1000 is appropriate).
- b) Do not either touch glass plates by hand or have any object come in contact with glass surfaces. Should dirt stick to a glass surface, blow it off with an air blower. (For dirt stuck through static electricity ionized air is recommended.)
- c) Clean with a cotton bud and ethyl alcohol if the grease stained. Be careful not to scratch the glass.
- d) Keep in a case to protect from dust and dirt. To prevent dew condensation, preheat or precool when moving to a room with great temperature differences.
- e) When a protective tape is applied before shipping, just before use remove the tape applied for electrostatic protection. Do not reuse the tape.

4) Do not expose to strong light (sun rays) for long periods.

5) Exposure to high temperature or humidity will affect the characteristics. Accordingly avoid storage or usage in such conditions.

6) CCD image sensors are precise optical equipment that should not be subject to mechanical shocks.

Package Outline Unit: mm

16pin DIP (450mil)

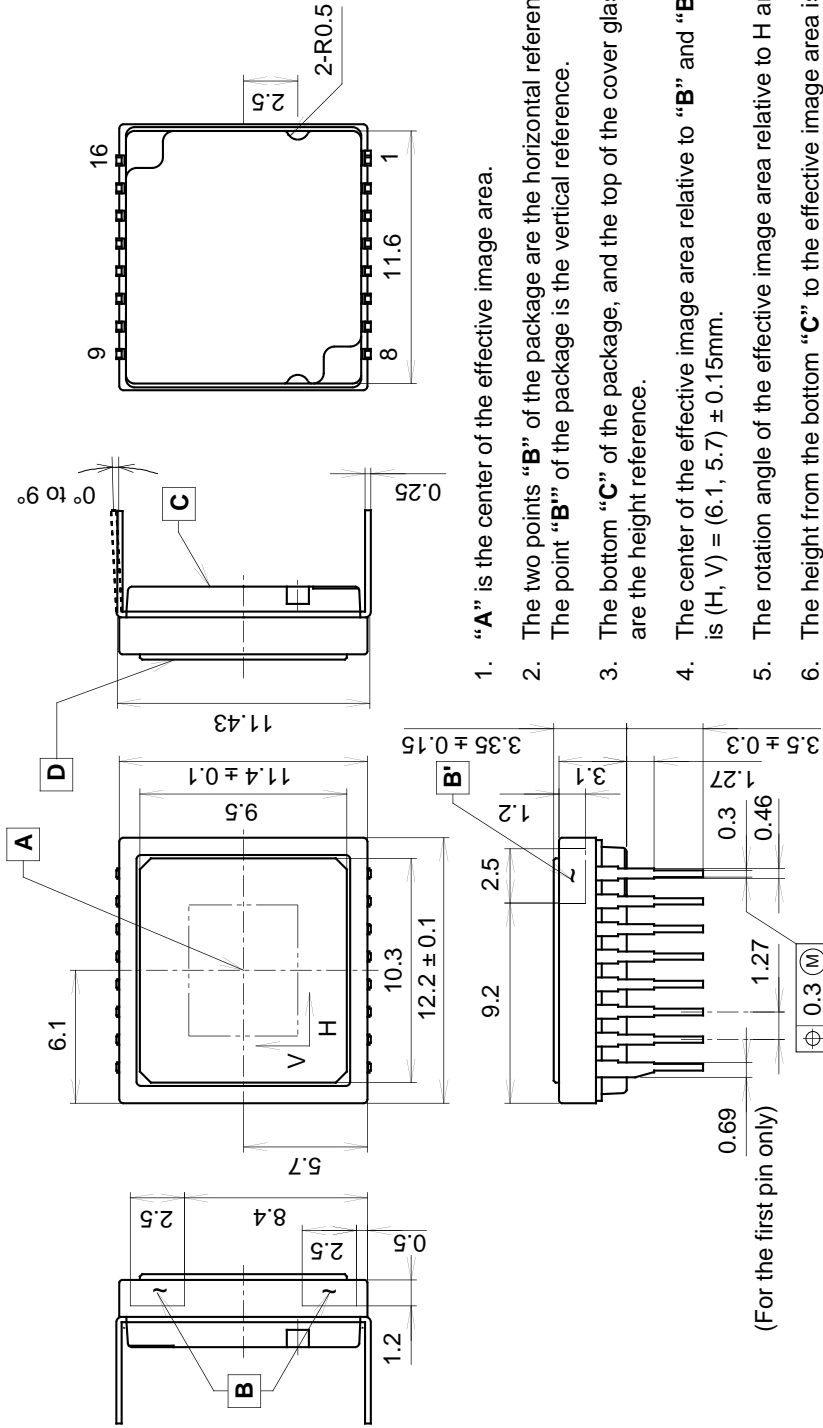

1. "A" is the center of the effective image area.
2. The two points "B" of the package are the horizontal reference. The point "B'" of the package is the vertical reference.
3. The bottom "C" of the package, and the top of the cover glass "D" are the height reference.
4. The center of the effective image area relative to "B" and "B'" is (H, V) = (6.1, 5.7) ± 0.15mm.
5. The rotation angle of the effective image area relative to H and V is ± 1°.
6. The height from the bottom "C" to the effective image area is 1.41 ± 0.10mm. The height from the top of the cover glass "D" to the effective image area is 1.94 ± 0.15mm.
7. The tilt of the effective image area relative to the bottom "C" is less than 50µm. The tilt of the effective image area relative to the top "D" of the cover glass is less than 50µm.
8. The thickness of the cover glass is 0.75mm, and the refractive index is 1.5.
9. The notches on the bottom of the package are used only for directional index, they must not be used for reference of fixing.

PACKAGE STRUCTURE

PACKAGE MATERIAL	Plastic
LEAD TREATMENT	GOLD PLATING
LEAD MATERIAL	42 ALLOY
PACKAGE WEIGHT	0.9g