

FEATURES

- Rise/Fall Time..... **4.0ns**
- Swing **65VP-P**
- Supply Voltage..... **100V**

APPLICATIONS

- CRT driver for up to 89kHz monitors with resolution up to 1280 x 1024.
- Excellent Gray Scale Linearity
- Emitter Peaking Option
- Adjustable Gain

DESCRIPTION

The CVA2401T contains three wideband amplifiers, designed specifically to drive a CRT. It features no crossover distortion for excellent gray scale linearity, external emitter peaking to maximize the high frequency gain at cross hatch pattern and adjustable gain for ease of use. This device can drive monitors with resolutions of 1280 x 1024 (non-interlaced) with pixel frequency of 210MHz.

The part is housed in the industry standard 11-lead TO-220 molded power package. The heat sink is grounded.

ORDERING INFORMATION

Part	Package	Temperature
CVA2401T	T11A	0°C to +110°C

CONNECTION DIAGRAM

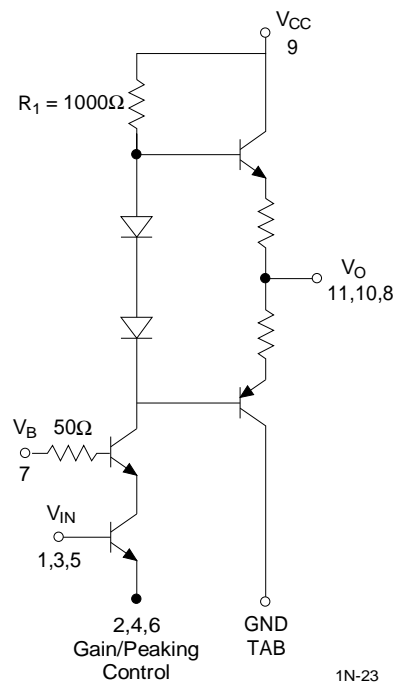
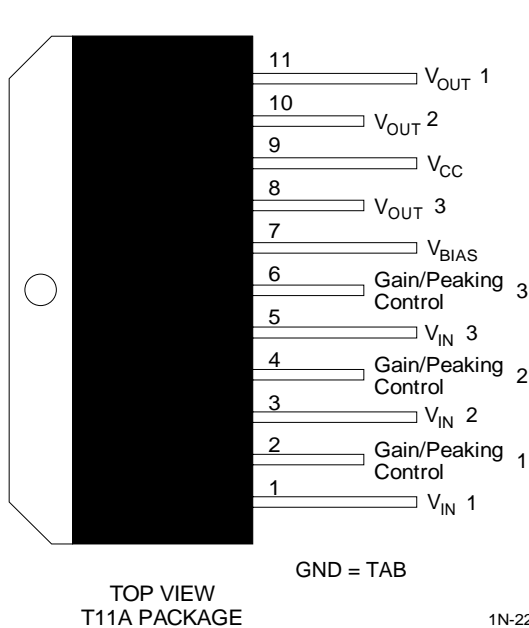

ABSOLUTE MAXIMUM RATINGS

Supply Voltage	100V	Case Temperature	0°C to +110°C
Storage Temperature	-25°C to +125°C	Lead Temperature	+300°C
Junction Temperature	+175°C		

DC ELECTRICAL CHARACTERISTICS $V_s = 80V$, $C_L = 8pF$, $DC_{INPUT\ BIAS} = 12V$, $V_{IN} = 3.2V$, $V_{OUT} = 50V_{p-p}$. $T_{CASE} = +25^\circ C$. See Figure 1.

SYMBOL	CHARACTERISTICS	MIN	TYP	MAX	UNITS
I_{CC}	Supply Current	38	43	48	mA
$V_{OUT\ DC}$	Output DC Level	40	45	50	V
A_v	Voltage Gain	14	14.4	15	V
R_{IN}	Input Impedance	10,000	12,000	20,000	Ω
	Gain Matching		0.2	0.7	dB

AC ELECTRICAL CHARACTERISTICS $V_s = 80V$, $C_L = 8pF$, $DC_{INPUT\ BIAS} = 12V$, $V_{IN} = 3.2V$, $V_{OUT} = 50V_{p-p}$. $T_{CASE} = +25^\circ C$. See Figure 1.

SYMBOL	CHARACTERISTICS	MIN	TYP	MAX	UNITS
T_r	Rise Time		4	5.0	ns
T_f	Fall Time		4	5.0	ns
L_e	Linearity		6		%
OS	Overshoot		3	7	%

FIGURE 1. TEST CIRCUIT

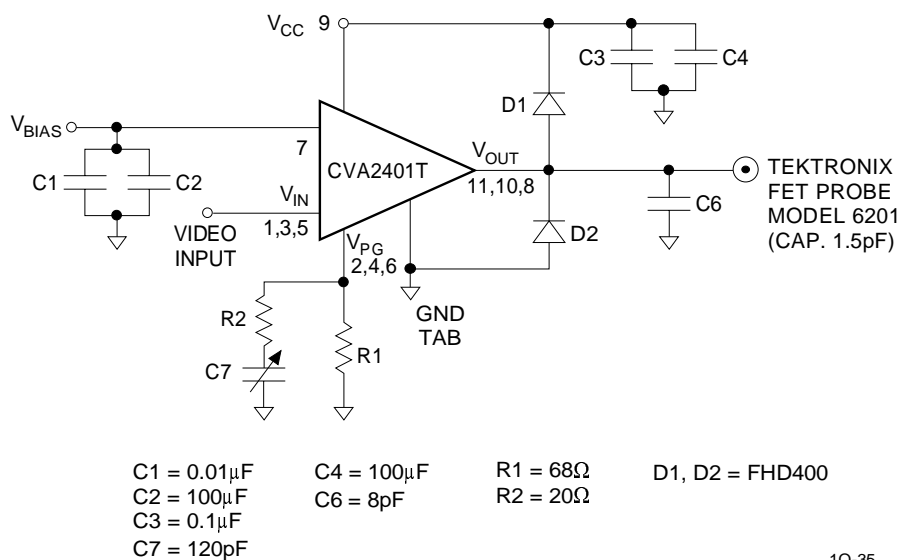
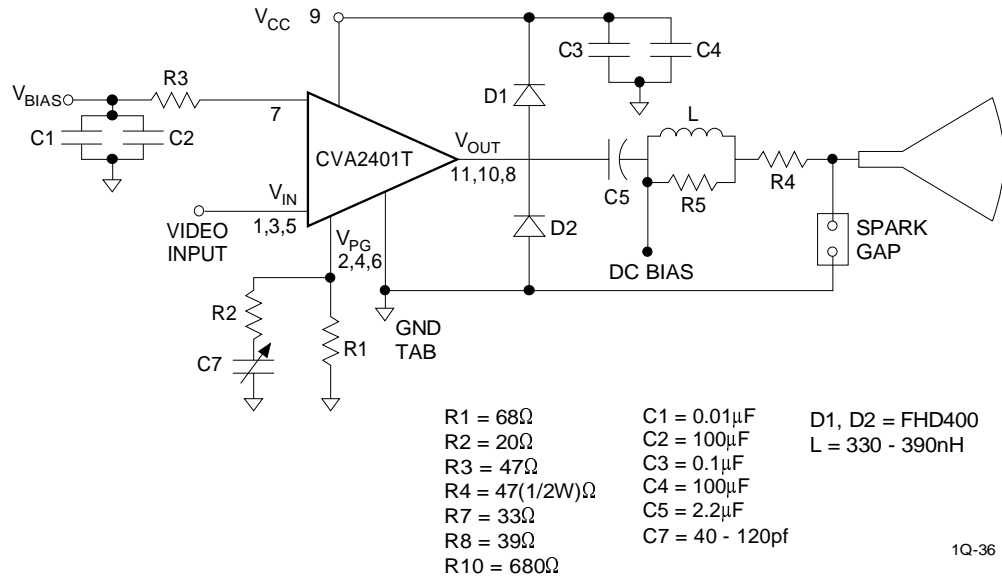

FIGURE 2. APPLICATION CIRCUIT



APPLICATION INFORMATION

The CVA2401T is a high voltage triple CRT driver suitable for VGA, Super VGA, IBM® 8514, 1280 x 1024 and 1024 x 768 non-interlaced display applications. The CVA2401T features 80V operation. The part is housed in the industry standard 11 lead TO-220 molded power package. The heat sink is grounded for ease of manufacturing and RFI shielding.

Thermal Considerations

The transfer characteristics of the amplifier are shown in *Figure 3*. Since this is a class A input stage, power supply current increases as the input signal increases and consequently power dissipation also increases.

The CVA2401T cannot be used without heat sinking. *Figure 3* shows the power dissipated in each channel over the operating voltage range of the device. Under white screen conditions, i.e.: 25V output, dissipation increases to 13.2W total. The CVA2401T case temperature must be maintained below +100°C. If the maximum expected ambient temperature is +50°C, then a heat sink is needed with thermal resistance equal to or less than:

$$R_{th} = \frac{(100 - 50^{\circ}\text{C})}{13.2\text{W}} = 3.8^{\circ}\text{C/W}$$

The CVA2401T maximum load is 600Ω to ground or V⁺.

The output of CVA2401T is not short circuit proof. Any resistance to V⁺ or Ground should be > 600Ω.

FIGURE 3. CVA2401T DC Characteristics

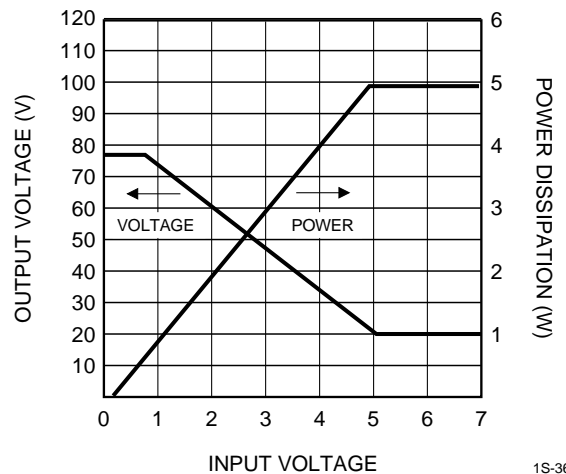

TYPICAL CHARACTERISTICS

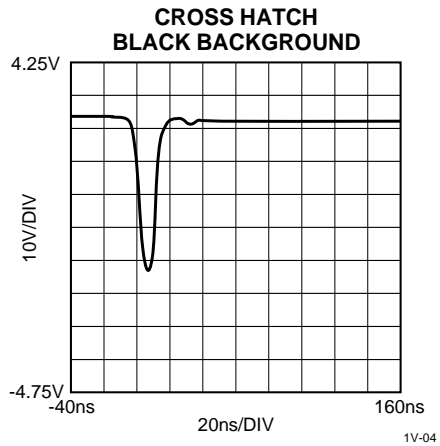
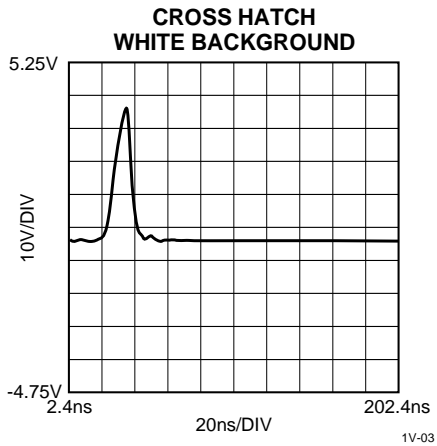
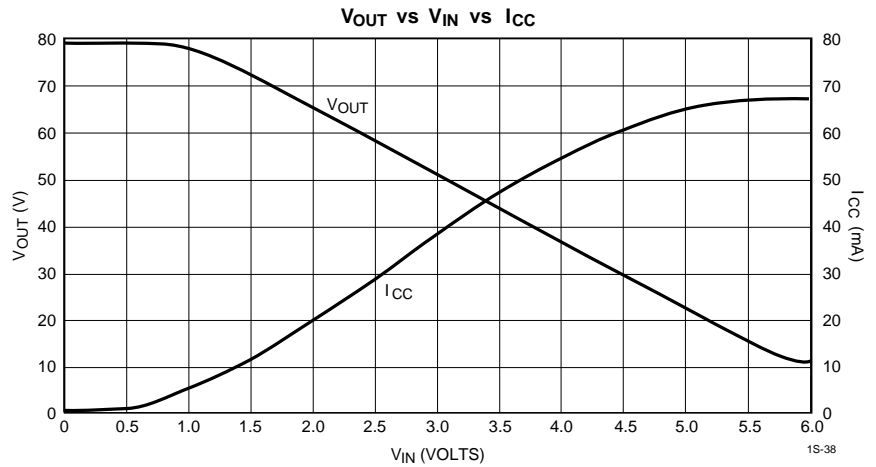
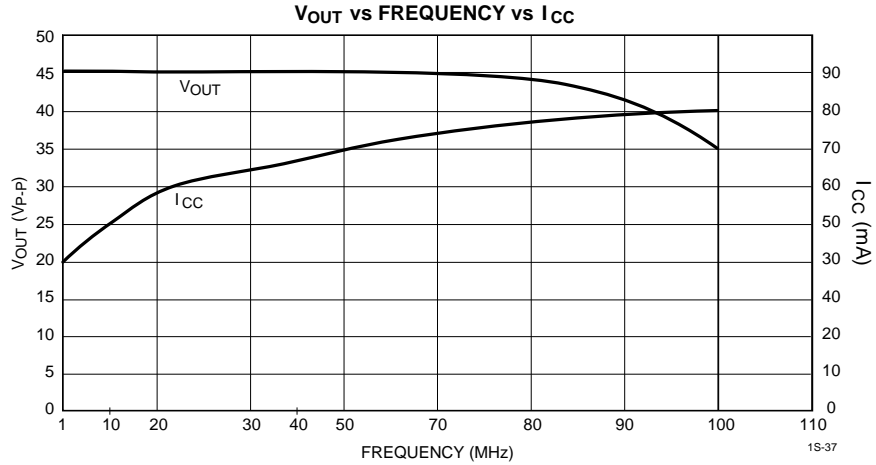

TYPICAL CHARACTERISTICS (continued)

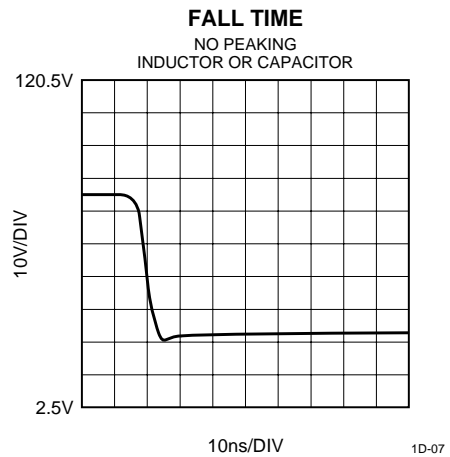
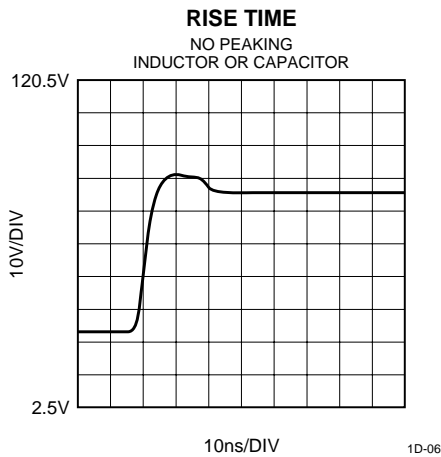
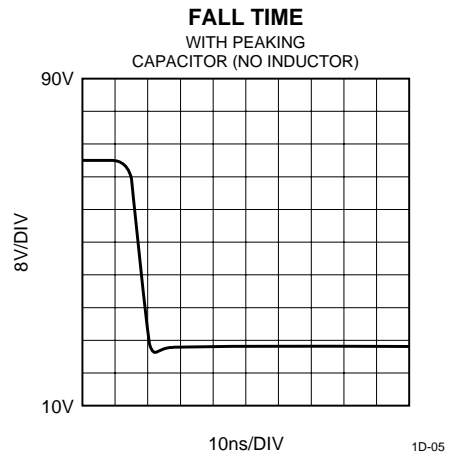
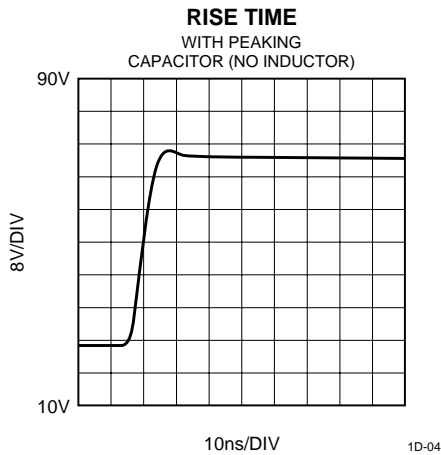
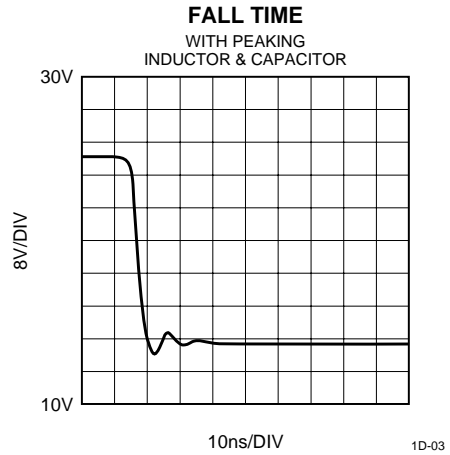
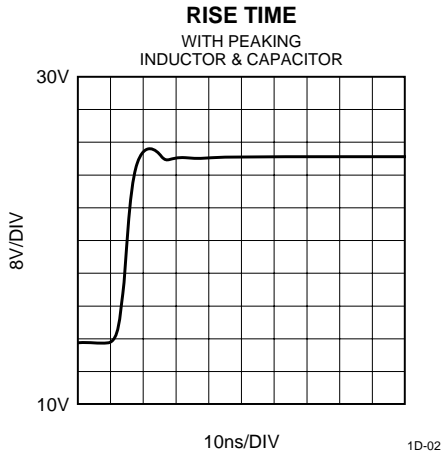

Information furnished by Calogic is believed to be accurate and reliable. However, no responsibility is assumed for its use: nor for any infringement of patents or other rights of third parties which may result from its use. No license is granted by implication or otherwise under any patent rights of Calogic.