

## Document Title

64K x16 bit 3.0V Super Low Power Full CMOS Slow SRAM

## Revision History

<u>Revision No</u>	<u>History</u>	<u>Draft Date</u>	<u>Remark</u>
03	Divide output load into two factors - tCLZ,tOLZ,tBLZ,tCHZ,tOHZ,tBHZ,tWHZ,tOW - Others Add marking information	Dec.10. 2000	Final
04	Add 100ns speed	Dec.27. 2000	Final

## DESCRIPTION

The HY62UF16101C is a high speed, super low power and 1M bit full CMOS SRAM organized as 65,536 words by 16bit. The HY62UF16101C uses high performance full CMOS process technology and designed for high speed low power circuit technology. It is particularly well suited for used in high density low power system application. This device has a data retention mode that guarantees data to remain valid at a minimum power supply voltage of 1.2V.

## FEATURES

- Fully static operation and Tri-state output
- TTL compatible inputs and outputs
- Battery backup(LL/SL-part)
  - 1.2V(min) data retention
- Standard pin configuration
  - 48 - FBGA

Product No.	Voltage (V)	Speed (ns)	Operation Current/Icc(mA)	Standby Current(uA)		Temperature (°C)
				LL	SL	
HY62UF16101C	2.7~3.3	55/70/85/100	3	5	1	0~70
HY62UF16101C-I	2.7~3.3	55/70/85/100	3	5	1	-40~85(I)

Note 1. Blank : Commercial, I : Industrial  
 2. Current value is max.

## PIN CONNECTION

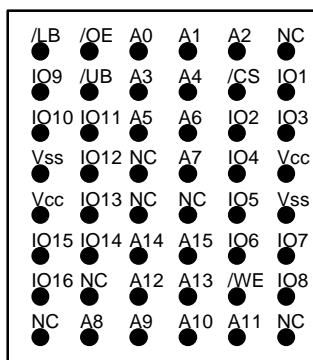

48-FBGA(Top View)

## BLOCK DIAGRAM

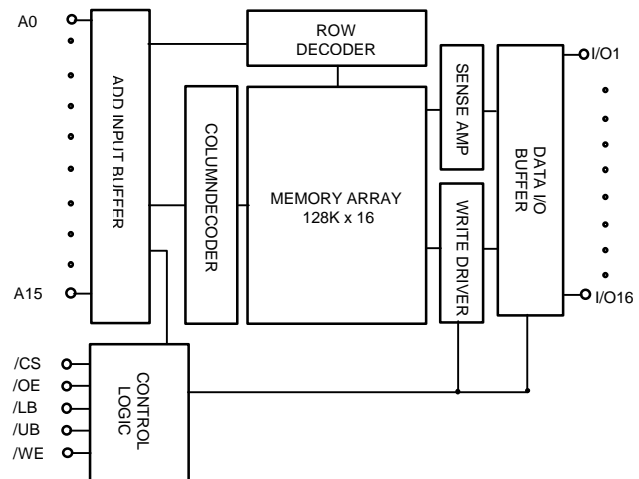

## PIN DESCRIPTION

Pin Name	Pin Function	Pin Name	Pin Function
/CS	Chip Select	I/O1~I/O16	Data Inputs / Outputs
/WE	Write Enable	A0~A15	Address Inputs
/OE	Output Enable	Vcc	Power(2.7V~3.3V)
/LB	Low Byte Control(I/O1~I/O8)	Vss	Ground
/UB	Upper Byte Control(I/O9~I/O16)	NC	No Connection

**ORDERING INFORMATION**

Part No.	Speed	Power	Temp.	Package
HY62UF16101CLLF	55/70/85/100	LL-part		FBGA
HY62UF16101CLLF-I	55/70/85/100	LL-part	I	FBGA
HY62UF16101CSLF	55/70/85/100	SL-part		FBGA
HY62UF16101CSLF-I	55/70/85/100	SL-part	I	FBGA

Note 1 Blank : Commercial, I : Industrial

**ABSOLUTE MAXIMUM RATING (1)**

Symbol	Parameter	Rating	Unit	Remark
V <sub>IN</sub> , V <sub>OUT</sub>	Input/Output Voltage	-0.2 to 3.6	V	
V <sub>CC</sub>	Power Supply	-0.2 to 4.6	V	
T <sub>A</sub>	Operating Temperature	0 to 70	°C	HY62UF16101C
		-40 to 85	°C	HY62UF16101C-I
T <sub>STG</sub>	Storage Temperature	-55 to 150	°C	
P <sub>D</sub>	Power Dissipation	1.0	W	
T <sub>SOLDER</sub>	Lead Soldering Temperature & Time	260•10	°C•sec	

Note

- Stresses greater than those listed under ABSOLUTE MAXIMUM RATINGS may cause permanent damage to the device. This is stress rating only and the functional operation of the device under these or any other conditions above those indicated in the operation of this specification is not implied. Exposure to the absolute maximum rating conditions for extended period may affect reliability.

**TRUTH TABLE**

/CS	/WE	/OE	/LB	/UB	Mode	I/O		Power
						I/O1~I/O8	I/O9~I/O16	
H	X	X	X	X	Deselected	High-Z	High-Z	Stand by
X	X	X	H	H	Deselected	High-Z	High-Z	Stand by
L	H	H	L	X	Output Disabled	High-Z	High-Z	Active
L	H	H	X	L	Output Disabled	High-Z	High-Z	Active
L	H	L	L	H	Read	DOUT	Hi-Z	Active
			H	L		Hi-Z	DOUT	
			L	L		DOUT	DOUT	
L	L	X	L	H	Write	DIN	Hi-Z	Active
			H	L		Hi-Z	DIN	
			L	L		DIN	DIN	

Note:

- H=V<sub>IH</sub>, L=V<sub>IL</sub>, X=don't care(V<sub>IH</sub> or V<sub>IL</sub>)
- /UB, /LB(Upper, Lower Byte enable)  
 These active LOW inputs allow individual bytes to be written or read.  
 When /LB is LOW, data is written or read to the lower byte, I/O 1 -I/O 8.  
 When /UB is LOW, data is written or read to the Upper byte, I/O 9 -I/O 16.

**RECOMMENDED DC OPERATING CONDITION**

Symbol	Parameter	Min.	Typ.	Max.	Unit
V <sub>CC</sub>	Supply Voltage	2.7	3.0	3.3	V
V <sub>SS</sub>	Ground	0	0	0	V
V <sub>IH</sub>	Input High Voltage	2.2	-	V <sub>CC</sub> +0.3	V
V <sub>IL</sub>	Input Low Voltage	-0.3(1)	-	0.6	V

Note : 1. V<sub>IL</sub> = -1.5V for pulse width less than 30ns  
 2. Undershoots are sampled and not 100% tested.

**DC ELECTRICAL CHARACTERISTICS**

V<sub>CC</sub> = 2.7V~3.3V, T<sub>A</sub> = 0°C to 70°C / -40°C to 85°C (I)

Sym	Parameter	Test Condition	Min.	Typ.	Max.	Unit	
I <sub>LI</sub>	Input Leakage Current	V <sub>SS</sub> ≤ V <sub>IN</sub> ≤ V <sub>CC</sub>	-1	-	1	uA	
I <sub>LO</sub>	Output Leakage Current	V <sub>SS</sub> ≤ V <sub>OUT</sub> ≤ V <sub>CC</sub> , /CS = V <sub>IH</sub> or /OE = V <sub>IH</sub> or /WE = V <sub>IL</sub> , /UB = /LB = V <sub>IH</sub>	-1	-	1	uA	
I <sub>CC</sub>	Operating Power Supply Current	/CS = V <sub>IL</sub> , V <sub>IN</sub> = V <sub>IH</sub> or V <sub>IL</sub> , I <sub>I/O</sub> = 0mA	-	-	3	mA	
I <sub>CC1</sub>	Average Operating Current	/CS ≤ 0.2V, 1us Cycle Time, 100% Duty, I <sub>I/O</sub> = 0mA, V <sub>IN</sub> ≤ 0.2V	-	-	5	mA	
		/CS = V <sub>IL</sub> , V <sub>IN</sub> = V <sub>IH</sub> or V <sub>IL</sub> Cycle Time = Min. 100% Duty I <sub>I/O</sub> = 0mA	-	-	45	mA	
I <sub>SB</sub>	TTL Standby Current (TTL Input)	/CS = V <sub>IH</sub> or /UB = /LB = V <sub>IH</sub> , V <sub>IN</sub> = V <sub>IH</sub> or V <sub>IL</sub>	-	-	0.5	mA	
I <sub>SB1</sub>	Standby Current (CMOS Input)	/CS ≥ V <sub>CC</sub> - 0.2V or /UB = /LB ≥ V <sub>CC</sub> - 0.2V, V <sub>IN</sub> ≥ V <sub>CC</sub> - 0.2V or V <sub>IN</sub> ≤ V <sub>SS</sub> + 0.2V	SL	-	-	1	uA
			LL		0.5	5	uA
V <sub>OL</sub>	Output Low Voltage	I <sub>OL</sub> = 2.1mA	-	-	0.4	V	
V <sub>OH</sub>	Output High Voltage	I <sub>OH</sub> = -1.0mA	2.4	-	-	V	

Note : 1. Typical values are at V<sub>CC</sub> = 3.0V, T<sub>A</sub> = 25°C  
 2. Typical values are sampled and not 100% tested.

**CAPACITANCE**

(Temp = 25°C, f = 1.0MHz)

Symbol	Parameter	Condition	Max.	Unit
C <sub>IN</sub>	Input Capacitance(Add, /CS, /UB, /LB, /WE, /OE)	V <sub>IN</sub> = 0V	8	pF
C <sub>OUT</sub>	Output Capacitance(I/O)	V <sub>I/O</sub> = 0V	10	pF

Note : These parameters are sampled and not 100% tested

**AC CHARACTERISTICS**

V<sub>CC</sub> = 2.7~3.3V, T<sub>A</sub> = 0°C to 70°C / -40°C to 85°C (I), unless otherwise specified

#	Symbol	Parameter	-55		-70		-85		-10		Unit
			Min	Max	Min	Max	Min	Max	Min	Max	
READ CYCLE											
1	t <sub>RC</sub>	Read Cycle Time	55	-	70	-	85	-	100	-	ns
2	t <sub>AA</sub>	Address Access Time	-	55	-	70	-	85	-	100	ns
3	t <sub>ACS</sub>	Chip Select Access Time	-	55	-	70	-	85	-	100	ns
4	t <sub>OE</sub>	Output Enable to Output Valid	-	35	-	40	-	45	-	50	ns
5	t <sub>BA</sub>	/LB, /UB Access Time	-	55	-	70	-	85	-	100	ns
6	t <sub>CLZ</sub>	Chip Select to Output in Low Z	10	-	10	-	10	-	20	-	ns
7	t <sub>OLZ</sub>	Output Enable to Output in Low Z	5	-	5	-	5	-	5	-	ns
8	t <sub>BLZ</sub>	/LB, /UB Enable to Output in Low Z	5	-	5	-	5	-	10	-	ns
9	t <sub>CHZ</sub>	Chip Deselection to Output in High Z	0	30	0	30	0	30	0	30	ns
10	t <sub>OHZ</sub>	Out Disable to Output in High Z	0	30	0	30	0	30	0	30	ns
11	t <sub>BHZ</sub>	/LB, /UB Disable to Output in High Z	0	30	0	30	0	30	0	30	ns
12	t <sub>OH</sub>	Output Hold from Address Change	10	-	10	-	10	-	15	-	ns
WRITE CYCLE											
13	t <sub>WC</sub>	Write Cycle Time	55	-	70	-	85	-	100	-	ns
14	t <sub>CW</sub>	Chip Selection to End of Write	50	-	60	-	70	-	80	-	ns
15	t <sub>AW</sub>	Address Valid to End of Write	50	-	60	-	70	-	80	-	ns
16	t <sub>BW</sub>	/LB, /UB Valid to End of Write	50	-	60	-	70	-	80	-	ns
17	t <sub>AS</sub>	Address Set-up Time	0	-	0	-	0	-	0	-	ns
18	t <sub>WP</sub>	Write Pulse Width	45	-	50	-	55	-	75	-	ns
19	t <sub>WR</sub>	Write Recovery Time	0	-	0	-	0	-	0	-	ns
20	t <sub>WHZ</sub>	Write to Output in High Z	0	20	0	25	0	30	0	35	ns
21	t <sub>DW</sub>	Data to Write Time Overlap	25	-	30	-	35	-	45	-	ns
22	t <sub>DH</sub>	Data Hold from Write Time	0	-	0	-	0	-	0	-	ns
23	t <sub>OW</sub>	Output Active from End of Write	5	-	5	-	5	-	10	-	ns

**AC TEST CONDITIONS**

T<sub>A</sub> = 0°C to 70°C / -40°C to 85°C (I), unless otherwise specified

Parameter	Value	
Input Pulse Level	0.4V to 2.2V	
Input Rise and Fall Time	5ns	
Input and Output Timing Reference Level	1.5V	
Output Load	CL = 5pF + 1TTL Load	
	Others	CL = 30pF + 1TTL Load

**AC TEST LOADS**

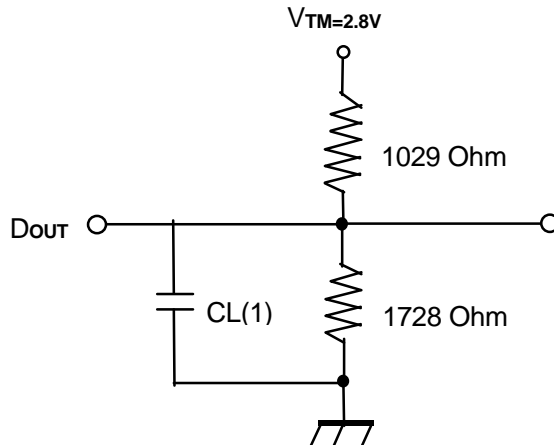

Note

1. Including jig and scope capacitance

**TIMING DIAGRAM**

**READ CYCLE 1 (Note 1,4)**

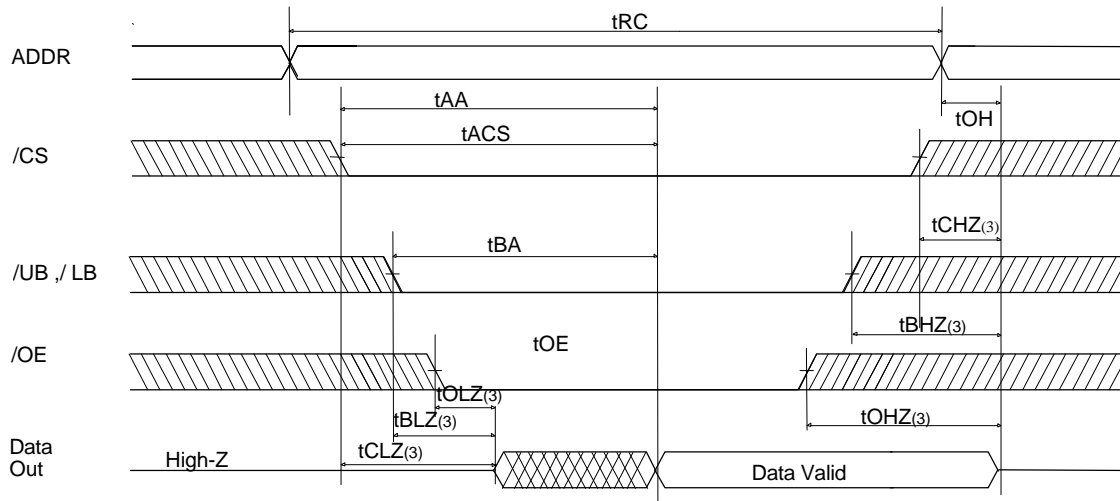

**READ CYCLE 2 (Note 1,2,4)**

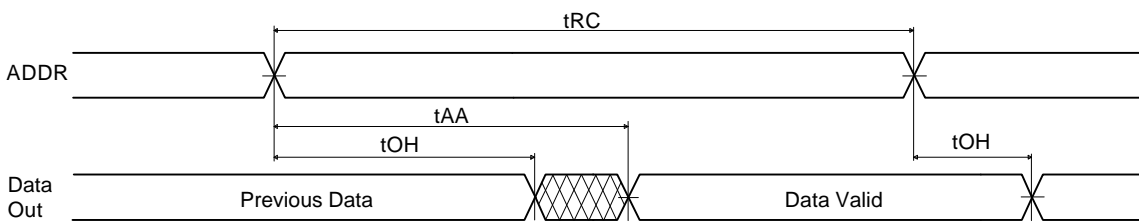

**READ CYCLE 3 (Note 1,2,4)**

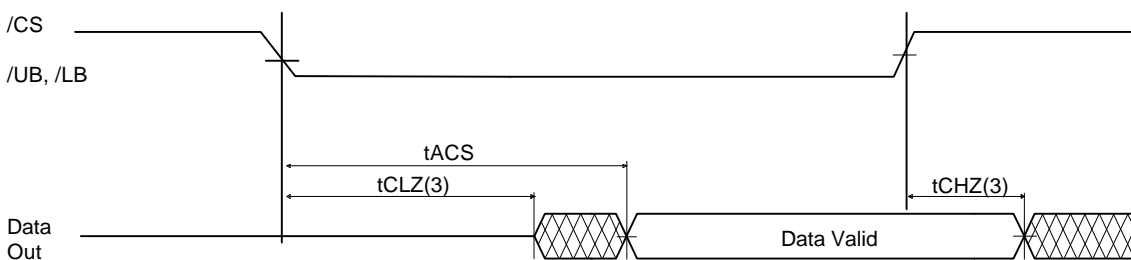

**Notes:**

- 1. A read occurs during the overlap of a low /OE, a high /WE, a low /CS1 and low /UB and/or /LB.
- 2. /OE = V<sub>IL</sub>
- 3. Transition is measured ± 200mV from steady state voltage.  
This parameter is sampled and not 100% tested.
- 4. /CS in high for the standby, low for active  
/UB and /LB in high for the standby, low for active

WRITE CYCLE 1(1,4,8) (/WE Controlled)

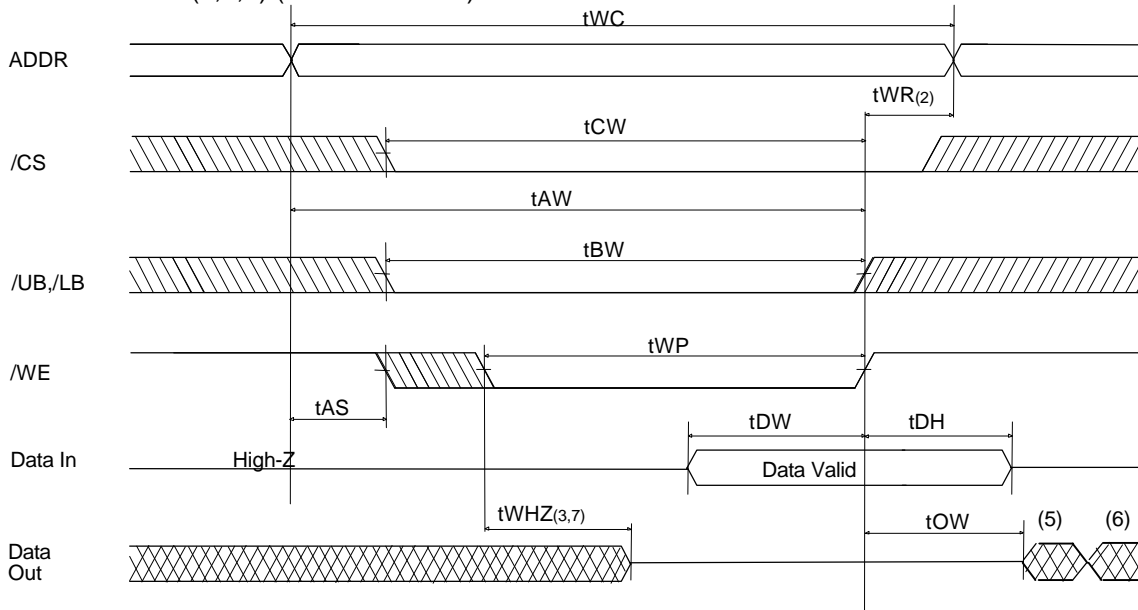

WRITE CYCLE 2 (Note 1,4,8) (/CS Controlled)

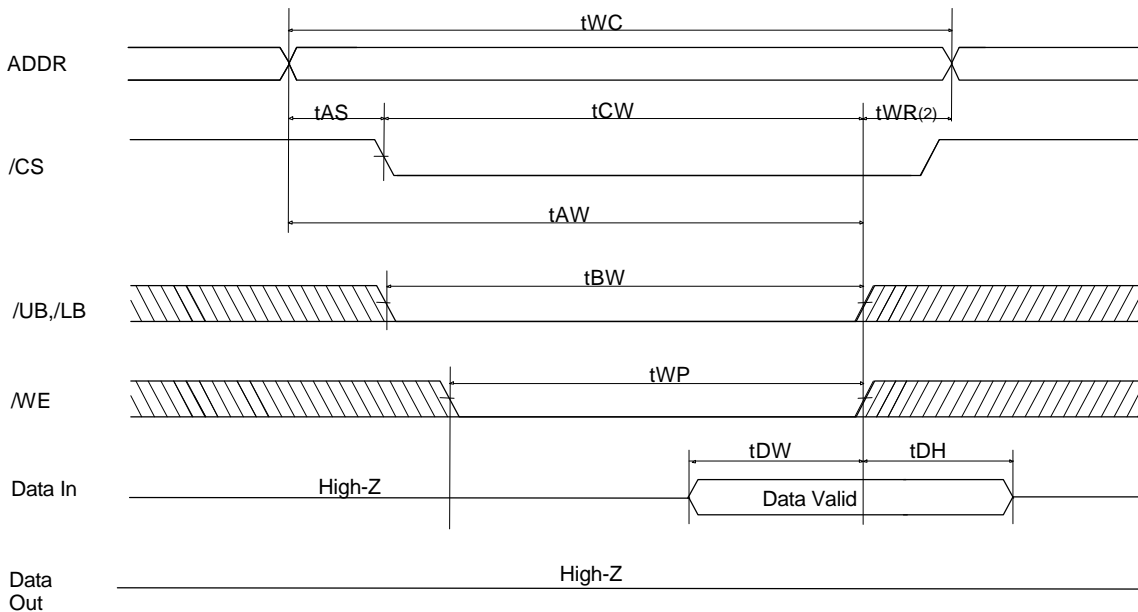

Notes:

1. A write occurs during the overlap of a low /WE, a low /CS1 and low /UB and/or /LB.
2. t<sub>WR</sub> is measured from the earlier of /CS, /LB, /UB, or /WE going high to the end of write cycle.
3. During this period, I/O pins are in the output state so that the input signals of opposite phase to the output must not be applied.
4. If the /CS, /LB and /UB low transition occur simultaneously with the /WE low transition or after the /WE transition, outputs remain in a high impedance state.
5. Q(data out) is the same phase with the write data of this write cycle.
6. Q(data out) is the read data of the next address.
7. Transition is measured ± 200mV from steady state.  
This parameter is sampled and not 100% tested.
8. /CS in high for the standby, low for active  
/UB and /LB in high for the standby, low for active

**DATA RETENTION ELECTRIC CHARACTERISTIC**

TA=0°C to 70°C / -40°C to 85°C (I)

Symbol	Parameter	Test Condition	Min	Typ	Max	Unit	
VDR	Vcc for Data Retention	/CS ≥ Vcc - 0.2V or /UB = /LB ≥ Vcc-0.2V, VIN ≥ Vcc - 0.2V or VIN ≤ Vss + 0.2V	1.2	-	3.3	V	
ICDDR	Data Retention Current	Vcc=1.5V, /CS ≥ Vcc - 0.2V, /UB = /LB ≥ Vcc-0.2V, VIN ≥ Vcc - 0.2V or VIN ≤ Vss + 0.2V	LL	-	0.5	2	uA
			SL	-	-	1	uA
tCDR	Chip Deselect to Data Retention Time	See Data Retention Timing Diagram	0	-	-	ns	
tR	Operating Recovery Time		tRC(2)	-	-	ns	

Notes:

1. Typical values are under the condition of TA = 25°C.
2. tRC is read cycle time.

**DATA RETENTION TIMING DIAGRAM**

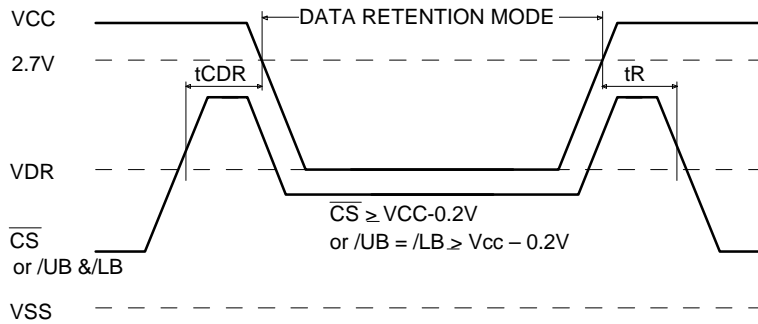



**PACKAGE INFORMATION**

48ball Fine-Pitch Ball Grid Array Package(F)

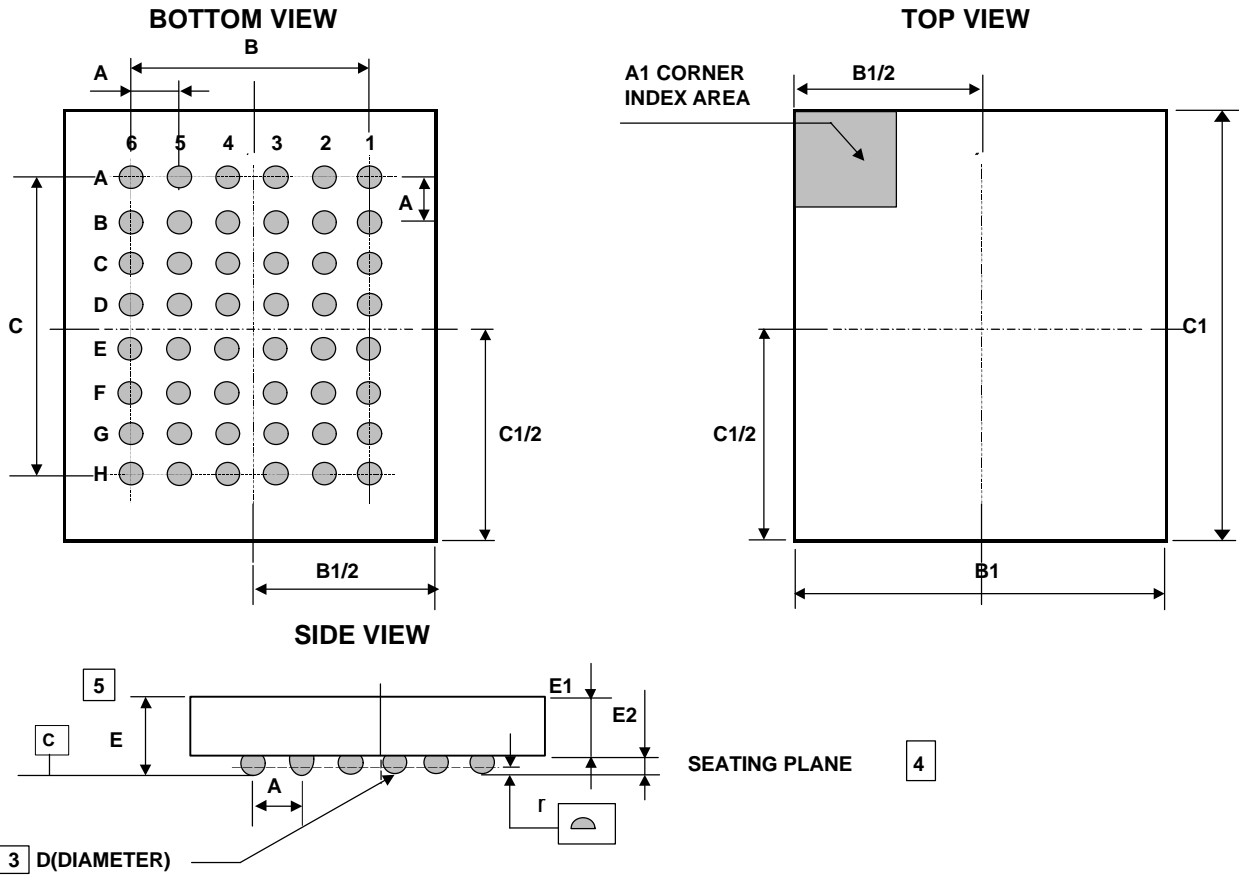

**Note**

1. DIMENSIONING AND TOLERANCING PER ASME Y14. SM-1994.
2. ALL DIMENSIONS ARE MILLIMETERS.
3. DIMENSION "D" IS MEASURED AT THE MAXIMUM SOLDER BALL DIAMETER IN A PLANE PARALLEL TO DATUM C.
4. PRIMARY DATUM C(SEATING PLANE) IS DEFINED BY THE CROWN OF THE SOLDER BALLS.
5. THIS IS A CONTROLLING DIMENSION.

Symbol	Min.	Typ.	Max.
A	-	0.75	-
B	-	3.75	-
B1	6.1	6.2	6.3
C	-	5.25	-
C1	6.2	6.3	6.4
D	0.3	0.35	0.4
E	0.9	1.0	1.1
E1	0.7	0.75	0.8
E2	0.2	0.25	0.3
r	-	-	0.1

**MARKING INSTRUCTION**

Package	Marking Example
FBGA	

<b>Index</b>
--------------

<ul style="list-style-type: none"> <li>• <b>HYUF611Cc</b></li> <li>• <b>c</b></li> <li>• <b>ss</b></li> <li>• <b>t</b></li> <li>• <b>yy</b></li> <li>• <b>ww</b></li> <li>• <b>p</b></li> <li>• <b>xxxxx</b></li> <li>• <b>KOR</b></li> </ul> <p><b>Note</b></p> <ul style="list-style-type: none"> <li>- Capital Letter</li> <li>- Small Letter</li> </ul>	<ul style="list-style-type: none"> <li>: Part Name</li> <li>: Power Consumption                             <ul style="list-style-type: none"> <li>- L : Low Low Power</li> <li>- S : Super Low Power</li> </ul> </li> <li>: Speed                             <ul style="list-style-type: none"> <li>- 55 : 55ns</li> <li>- 70 : 70ns</li> <li>- 85 : 85ns</li> <li>- 10 : 100ns</li> </ul> </li> <li>: Temperature                             <ul style="list-style-type: none"> <li>- C : Industrial ( -0 ~ 70 °C )</li> <li>- I : Industrial ( -40 ~ 85 °C )</li> </ul> </li> <li>: Year ( ex : 00 = year 2000, 01= year 2001 )</li> <li>: Work Week ( ex : 12 = work week 12 )</li> <li>: Process Code</li> <li>: Lot No.</li> <li>: Origin Country</li> </ul> <ul style="list-style-type: none"> <li>: Fixed Item</li> <li>: Non-fixed Item</li> </ul>
---	---