

Energy Management Controller IC

FEATURES

- Energy Management Controller
- Based on 8-bit RISC Technology
- Proprietary Power Management Algorithm
- Reduces the power consumption of induction motor systems
- 5V Operation
- 18-pin PDIP and SOIC Packages
- 8-bit Analog-to-Digital (A/D) Converter
- Automatic Power-on Reset
- Power-up Timer
- Commercial and Industrial Temperature Range Operation
- Multiple parts can be slaved for three-phase operation

INTRODUCTION

The MTE1122 is an Energy Management Controller IC for single-phase induction motors. This CMOS device is based on Microchip Technology Inc's RISC processor core and proprietary algorithms. When combined with some external analog components, it will provide an electronic system that economically reduces the operating costs of small induction motors by as much as 58%. It will also allow motors to run cooler and with less vibration. The system operates on single phase 110 or 220 VAC.

PACKAGE TYPE

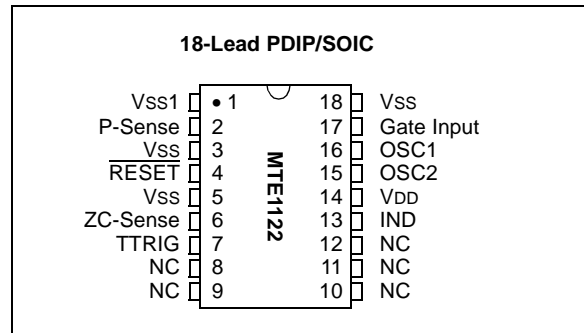

FIGURE 1: SYSTEM BLOCK DIAGRAM

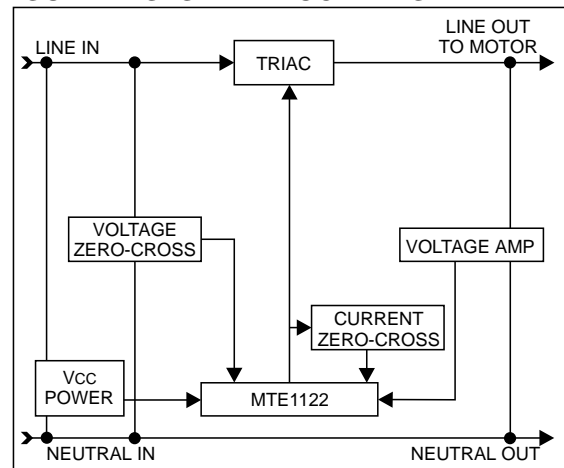
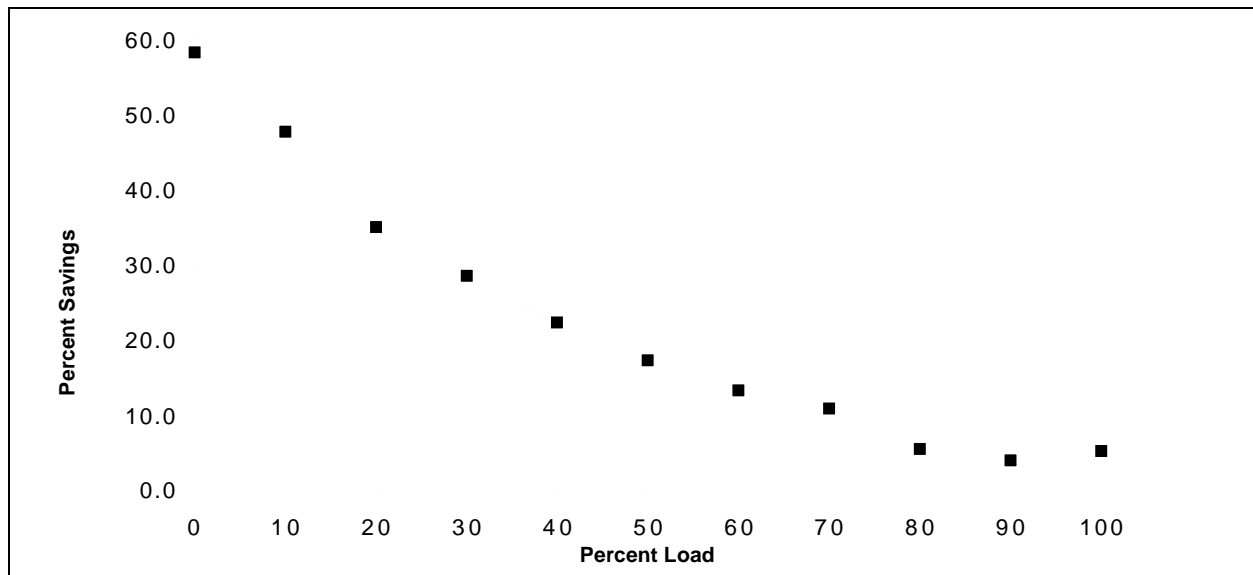

FIGURE 2: ENERGY SAVINGS



FUNCTIONAL DESCRIPTION

Single-phase induction motors run most efficiently at full load. As the applied load lessens, a greater portion of the energy consumed by the motor is wasted, mostly as heat.

It is estimated by the EPA that 50% of the energy produced in the US is consumed by small electric motors, and that 20% of this energy does no useful work. There are perhaps three major reasons for this:

1. Over-specification -- sometimes its easier or costs no more to specify a larger motor than determine actual loads.
2. Worst case design -- pumps, conveyers, fans, and the like must be able to operate properly with clogged filters, maximum heads, or specified loads. If filters are clean, or loads are lower, the motor will be running only partly loaded.
3. Idle time -- many times, systems can't be shut down conveniently when not in use.

Number 1 above can be corrected by proper design. For example, in modern refrigerators, the compressor systems have been optimized quite effectively. Numbers 2 and 3 can not be improved using traditional approaches. This is where the MTE1122 provides a new, cost-effective solution.

The MTE1122 calculates the amount of load on a motor connected to it, and adjusts the motor's supply voltage to match that load. For example, if the load is lower than the motor's rated load, the voltage to the motor can be reduced, thus decreasing the energy used by the motor.

A 1/3 HP motor will typically see 85 VAC at no load when powered through the MTE1122, for an energy savings of as much as 58%.

A system block diagram is shown in Figure 1. A graph of energy savings vs. motor load is shown in Figure 2.

A graph of motor efficiency with and without an MTE1122-based energy management controller (EMC) is shown in Figure 3. The data for the graphs are shown in Table 1. These figures are based on a 1/3 HP induction motor coupled to a dynamometer. Actual savings may vary based on motor size, motor load and motor construction.

PINOUT DESCRIPTIONS

P-Sense - analog input that is used by the device to measure the load voltage.

Gate Enable - analog input that monitors the voltage across the triac. It is used as a current feedback mechanism.

IND - TTL-compatible output that indicates that the system is operating normally. It is intended to control an LED or another indicator device.

ZC-Sense - TTL-compatible input that is used to determine the zero crossing point of the AC voltage waveform.

TTRIG - TTL-compatible output that is used to drive the triac.

RESET - TTL-compatible input used to reset the device by holding this pin low.

OSC1, OSC2 - Oscillator crystal or resonator connections.

FIGURE 3: MOTOR EFFICIENCY

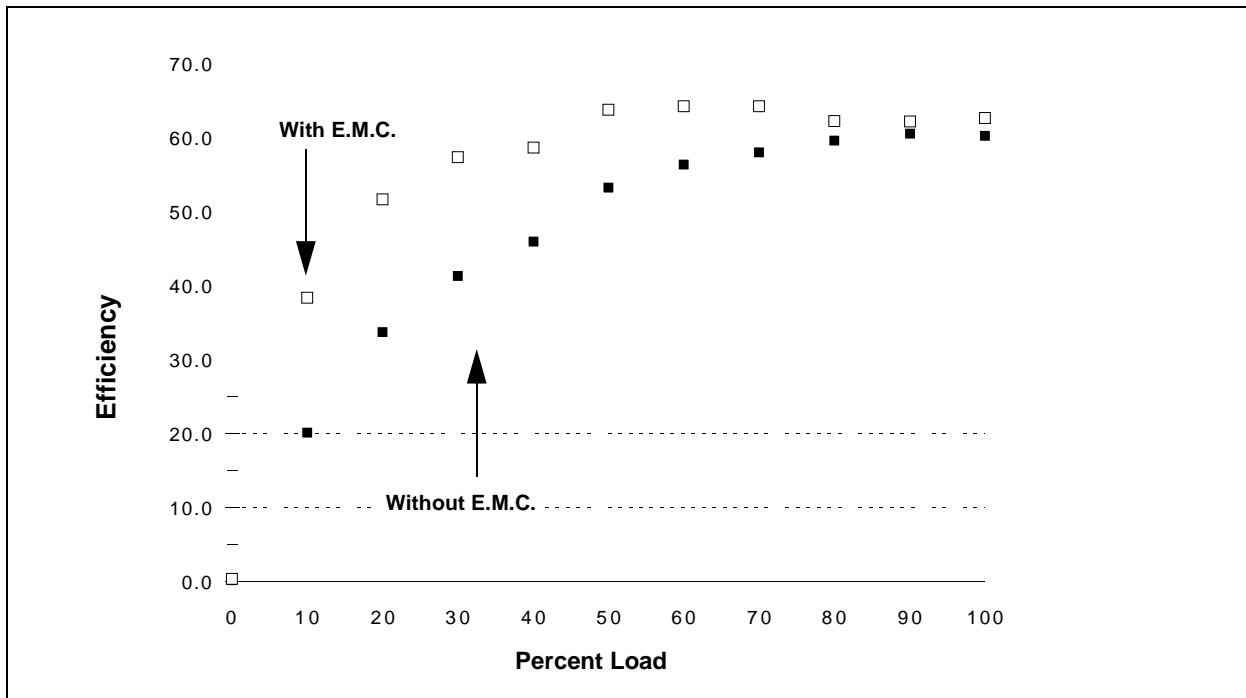

TABLE 1: OPERATING PARAMETER COMPARISONS

1/3 HP Motor without E.M.C.									
Load (%)	Load (Nm)	Vrms	Irms (A)	Power Factor	Power In (W)	RPM	Power Out (W)	Power Out (HP)	Efficiency (%)
0	0.00	115	5.7	0.18	120	1791	0	0.00	0.2
10	0.14	115	5.7	0.20	130	1788	26	0.04	20.1
20	0.29	115	5.7	0.24	160	1781	54	0.07	33.7
30	0.43	115	5.7	0.29	193	1777	80	0.11	41.4
40	0.57	115	5.7	0.35	229	1768	105	0.14	46.0
50	0.72	115	5.8	0.37	249	1764	133	0.18	53.3
60	0.86	115	5.8	0.42	280	1758	158	0.21	56.4
70	1.00	115	6.0	0.46	315	1750	183	0.25	58.0
80	1.14	116	6.1	0.49	348	1744	208	0.28	59.7
90	1.29	115	6.3	0.53	386	1736	234	0.31	60.6
100	1.43	116	6.5	0.57	428	1727	258	0.35	60.3

1/3 HP Motor with E.M.C.									
Load (%)	Load (Nm)	Vrms	Irms (A)	Power Factor	Power In (W)	RPM	Power Out (W)	Power Out (HP)	Efficiency (%)
0	0.00	113	3.1	0.14	50	1794	0	0.00	0.4
10	0.14	113	3.2	0.19	68	1786	26	0.04	38.4
20	0.29	113	3.5	0.26	104	1775	54	0.07	51.7
30	0.43	113	3.8	0.32	138	1764	79	0.11	57.4
40	0.57	113	4.1	0.38	178	1755	104	0.14	58.7
50	0.72	113	4.3	0.42	206	1749	132	0.18	63.8
60	0.86	112	4.6	0.47	243	1740	156	0.21	64.3
70	1.00	112	4.9	0.51	281	1730	181	0.24	64.3
80	1.14	112	5.3	0.55	329	1722	205	0.27	62.3
90	1.29	112	5.6	0.59	371	1713	231	0.31	62.2
100	1.43	111	6.0	0.61	406	1705	255	0.34	62.7

ELECTRICAL CHARACTERISTICS

Absolute Maximum Rating †

Ambient temperature under bias.....	-55 to +125°C
Storage Temperature.....	-65°C to +150°C
Voltage on any pin with respect to V _{SS} (except V _{DD} and RESET).....	-0.6V to V _{DD} +0.6V
Voltage on V _{DD} with respect to V _{SS}	0 to +7.5V
Voltage on RESET with respect to V _{SS} (Note 1).....	0 to +14V
Total power Dissipation (Note 2).....	800mW
Max. Current out of V _{SS} pin.....	150mA
Max. Current into V _{DD} pin.....	100mA
Input Clamping Current, I _{IK} (V _I <0 or V _I >V _{DD}).....	±20mA
Output Clamping Current, I _{OK} (V _O <0 or V _O >V _{DD}).....	±20mA
Max. Output Current sunk by any I/O pin.....	25mA
Max. Output Current sourced by any I/O pin.....	20mA

Note 1: Voltage spikes below V_{SS} at the RESET pin, inducing currents greater than 80mA, may cause latch-up. Thus, a series resistor of 50-100Ω should be used when applying a "low" level to the RESET pin rather than pulling this pin directly to V_{SS}.

Note 2: Total power dissipation should not exceed 800 mW for the package. Power dissipation is calculated as follows:

$$P_{DIS} = V_{DD} \times \{I_{DD} - \sum I_{OH}\} + \sum \{(V_{DD}-V_{OH}) \times I_{OH}\} + \sum (V_{OL} \times I_{OL})$$

†NOTICE: Stresses above those listed under "Maximum Ratings" may cause permanent damage to the device. This is a stress rating only and functional operation of the device or compliance to AC and DC parametric specifications at those or any other conditions above those indicated in the operation listings of this specification is not implied. Exposure to maximum rating conditions for extended periods may affect device reliability.

TABLE 2: DC CHARACTERISTICS POWER SUPPLY PINS

Standard Operating Conditions (unless otherwise stated)						
Operating temperature -40°C ≤ T _A ≤ +85°C for industrial, 0°C ≤ T _A ≤ +70°C for commercial						
Operating voltage V _{DD} = 4.0V to 6.0V						
Characteristic	Sym	Min	Typ (Note 1)	Max	Units	Conditions
Supply Voltage	V _{DD}	4.0		6.0	V	
V _{DD} start voltage to guarantee power on reset	V _{POR}		V _{SS}		V	
V _{DD} rise rate to guarantee Power-On Reset (Note 2)	S _{VDD}	0.05			V/ms	
Supply Current (Note 3)	I _{DD}		1.8	3.3	mA	FOSC = 4 MHz, V _{DD} = 5.5V

Note 1: Data in the column labeled "Typical" is based on characterization results at 25°C. This data is for design guidance only and is not tested for, or guaranteed by Microchip Technology.

2: This parameter is characterized but not tested.

3: The supply current is mainly a function of the operating voltage and frequency. Other factors such as I/O pin loading and switching rate, oscillator type, internal code execution pattern, and temperature also have an impact on the current consumption.

TABLE 3: DC CHARACTERISTICS: ALL PINS EXCEPT POWER SUPPLY

Standard Operating Conditions (unless otherwise stated) Operating temperature $-40^{\circ}\text{C} \leq T_A \leq +85^{\circ}\text{C}$ for industrial, $0^{\circ}\text{C} \leq T_A \leq +70^{\circ}\text{C}$ for commercial Operating voltage $V_{DD} = 4.0\text{V to }6.0\text{V}$						
Characteristic	Sym	Min	Typ	Max	Units	Conditions
All Pins Except Power Input Low Voltage: All Input Pins (Except OSC1) $\overline{\text{RESET}}$ OSC1	V_{IL} V_{IH}	V_{SS} V_{SS}		$0.2 V_{DD}$ $0.3 V_{DD}$	V V	
Input High Voltage: All Input Pins (Except $\overline{\text{RESET}}$, OSC1) $\overline{\text{RESET}}$ OSC1	V_{IH} V_{IH} V_{IH}	$0.36 V_{DD}$ $0.85 V_{DD}$ $0.7 V_{DD}$		V_{DD} V_{DD} V_{DD}	V V V	$4.5\text{V} \leq V_{DD} \leq 5.5\text{V}$
Input Leakage Current: (Notes 1,2) IND, TTRIG, AC-Sense P-Sense, Gate Input $\overline{\text{RESET}}$ OSC1	I_{IL}			± 1 ± 1 ± 1 ± 1	μA μA μA μA	$V_{SS} \leq V_{PIN} \leq V_{DD}$, Pin at hi-impedance $V_{SS} \leq V_{PIN} \leq V_{DD}$, Pin at hi-impedance $V_{SS} \leq V_{PIN} \leq V_{DD}$ $V_{SS} \leq V_{PIN} \leq V_{DD}$
Output Low Voltage: All Output Pins	V_{OL}			0.6	V	$I_{OL} = 8.5\text{mA}$, $V_{DD} = 4.5\text{V}$, $-40^{\circ}\text{C to }+85^{\circ}\text{C}$
Output High Voltage: All Output Pins (Note 2)	V_{OH}	$0.7 V_{DD}$			V	$I_{OH} 83.\text{mA}$, $V_{DD} = 4.5\text{V}$, $-40^{\circ}\text{C to }+85^{\circ}\text{C}$

Note 1: The leakage current on the $\overline{\text{RESET}}$ pin is strongly dependent on the applied voltage level. The specified levels represent normal operating conditions. Higher leakage current may be measured at different input voltages.

2: Negative current is defined as current coming out of the pin.

TABLE 4: AC CHARACTERISTICS

Standard Operating Conditions (unless otherwise stated) Operating temperature $-40^{\circ}\text{C} \leq T_A \leq +85^{\circ}\text{C}$ for industrial, $0^{\circ}\text{C} \leq T_A \leq +70^{\circ}\text{C}$ for commercial Operating voltage $V_{DD} = 4.0\text{V to }6.0\text{V}$						
Characteristic	Sym	Min	Typ	Max	Units	Conditions
Oscillator Frequency	FOSC	4		4	MHz	
Clock in (OSC1) High or Low Time	TCKHLXT	50			ns	Note 1
Clock in (OSC1) Rise or Fall Time	TCKRFXT	25			ns	Note 1
$\overline{\text{RESET}}$ Pulse Width (low)	TMCL	200			ns	Note 1

PACKAGING INFORMATION

Package Type: 18-Lead Plastic Dual In-Line (300 mil)

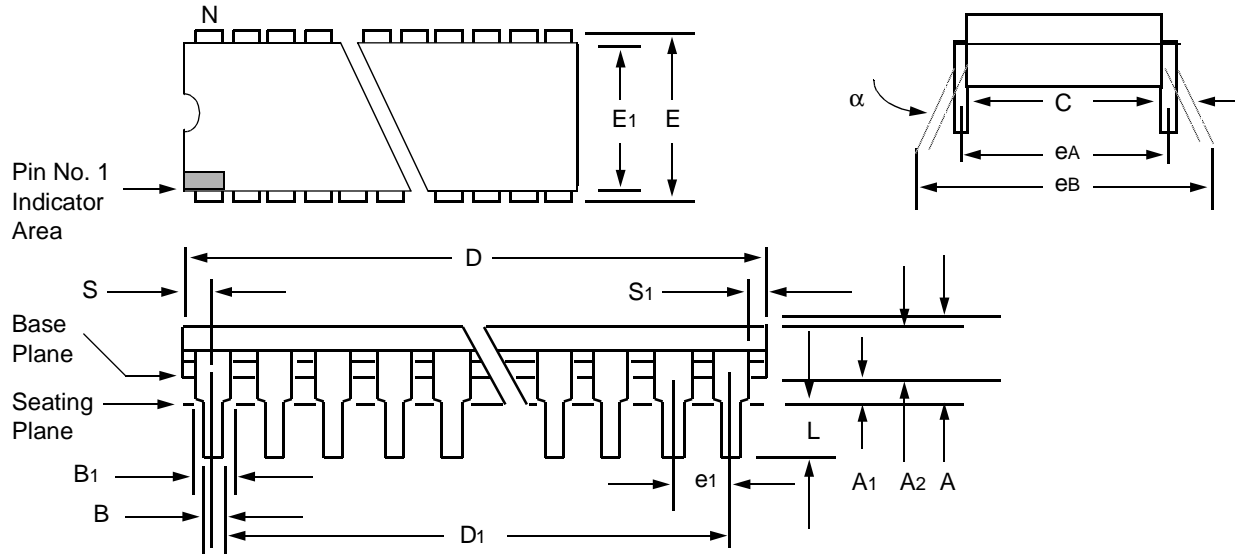

Package Group: Plastic Dual In-Line (PLA)						
Symbol	Millimeters			Inches		
	Min	Max	Notes	Min	Max	Notes
α	0°	10°		0°	10°	
A	—	4.064		—	0.160	
A1	0.381	-		0.015	—	
A2	3.048	3.810		0.120	0.150	
B	0.3556	0.5588		0.014	0.022	
B1	1.524	1.524	Reference	0.060	0.060	Reference
C	0.203	0.381	Typical	0.008	0.015	Typical
D	22.479	23.495		0.885	0.925	
D1	20.320	20.320	Reference	0.800	0.800	Reference
E	7.620	8.255		0.300	0.325	
E1	6.096	7.112		0.240	0.280	
e1	2.4892	2.5908	Typical	0.098	0.102	Typical
eA	7.620	7.620	Reference	0.300	0.300	Reference
eB	7.874	9.906		0.310	0.390	
L	3.048	3.556		0.120	0.140	
N	18	18		18	18	
S	0.889	—		0.035	—	
S1	0.508	—		0.005	—	

Package Type: 18-Lead Plastic Surface Mount (SOIC - Wide, 300 mil Body)

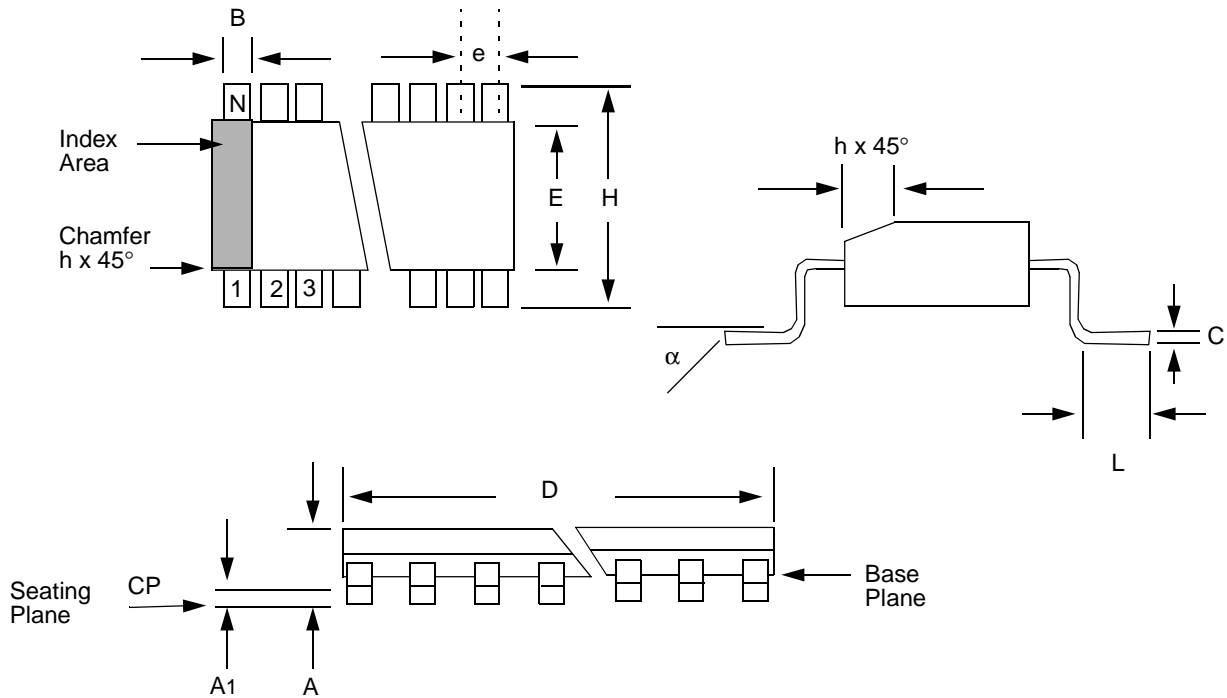

Package Group: Plastic SOIC (SO)						
Symbol	Millimeters			Inches		
	Min	Max	Notes	Min	Max	Notes
α	0°	8°		0°	8°	
A	2.3622	2.6416		0.093	0.104	
A1	0.1016	0.29972		0.004	0.0118	
B	0.3556	0.4826		0.014	0.019	
C	0.2413	0.3175		0.0095	0.0125	
D	11.3538	11.7348		0.447	0.462	
E	7.4168	7.5946		0.292	0.299	
e	1.270	1.270	Reference	0.050	0.050	Reference
H	10.0076	10.6426		0.394	0.419	
h	0.381	0.762		0.015	0.030	
L	0.4064	1.143		0.016	0.045	
N	18	18		18	18	
CP	—	0.1016		—	0.004	

MTE1122

MTE1122 Product Identification System

To order or to obtain information, e.g., on pricing or delivery, please use the listed part numbers, and refer to the factory or the listed sales offices.

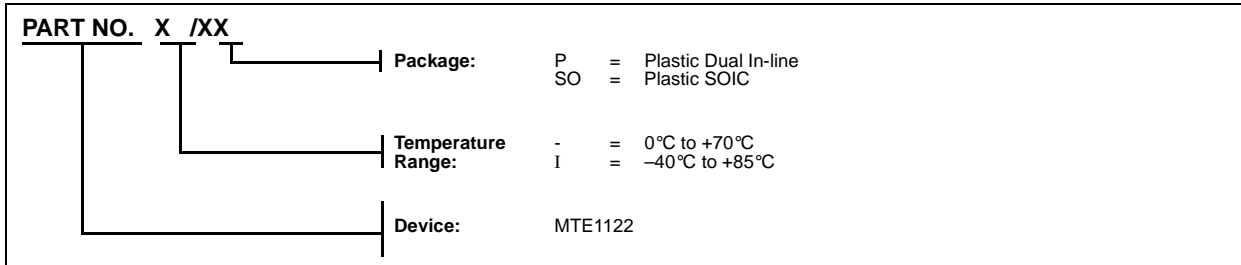

AMERICAS

Corporate Office

Microchip Technology Inc.
2355 West Chandler Blvd.
Chandler, AZ 85224-6199
Tel: 602 786-7200 Fax: 602 786-7277
Technical Support: 602 786-7627
Web: <http://www.mchip.com/biz/mchip>

Atlanta

Microchip Technology Inc.
500 Sugar Mill Road, Suite 200B
Atlanta, GA 30350
Tel: 770 640-0034 Fax: 770 640-0307

Boston

Microchip Technology Inc.
5 Mount Royal Avenue
Marlborough, MA 01752
Tel: 508 480-9990 Fax: 508 480-8575

Chicago

Microchip Technology Inc.
333 Pierce Road, Suite 180
Itasca, IL 60143
Tel: 708 285-0071 Fax: 708 285-0075

Dallas

Microchip Technology Inc.
14651 Dallas Parkway, Suite 816
Dallas, TX 75240-8809
Tel: 214 991-7177 Fax: 214 991-8588

Dayton

Microchip Technology Inc.
35 Rockridge Road
Englewood, OH 45322
Tel: 513 832-2543 Fax: 513 832-2841

Los Angeles

Microchip Technology Inc.
18201 Von Karman, Suite 455
Irvine, CA 92715
Tel: 714 263-1888 Fax: 714 263-1338

New York

Microchip Technology Inc.
150 Motor Parkway, Suite 416
Hauppauge, NY 11788
Tel: 516 273-5305 Fax: 516 273-5335

AMERICAS (continued)

San Jose

Microchip Technology Inc.
2107 North First Street, Suite 590
San Jose, CA 95131
Tel: 408 436-7950 Fax: 408 436-7955

ASIA/PACIFIC

Hong Kong

Microchip Technology
Unit No. 3002-3004, Tower 1
Metroplaza
223 Hing Fong Road
Kwai Fong, N.T. Hong Kong
Tel: 852 2 401 1200 Fax: 852 2 401 3431

Korea

Microchip Technology
168-1, Youngbo Bldg. 3 Floor
Samsung-Dong, Kangnam-Ku,
Seoul, Korea
Tel: 82 2 554 7200 Fax: 82 2 558 5934

Singapore

Microchip Technology
200 Middle Road
#10-03 Prime Centre
Singapore 188980
Tel: 65 334 8870 Fax: 65 334 8850

Taiwan

Microchip Technology
10F-1C 207
Tung Hua North Road
Taipei, Taiwan, ROC
Tel: 886 2 717 7175 Fax: 886 2 545 0139

EUROPE

United Kingdom

Arizona Microchip Technology Ltd.
Unit 6, The Courtyard
Meadow Bank, Furlong Road
Bourne End, Buckinghamshire SL8 5AJ
Tel: 44 0 1628 851077 Fax: 44 0 1628 850259

France

Arizona Microchip Technology SARL
2 Rue du Buisson aux Fraises
91300 Massy - France
Tel: 33 1 69 53 63 20 Fax: 33 1 69 30 90 79

Germany

Arizona Microchip Technology GmbH
Gustav-Heinemann-Ring 125
D-81739 Muenchen, Germany
Tel: 49 89 627 144 0 Fax: 49 89 627 144 44

Italy

Arizona Microchip Technology SRL
Centro Direzionale Colleoni
Palazzo Pegaso Ingresso No. 2
Via Paracelso 23, 20041
Agrate Brianza (MI) Italy
Tel: 39 039 689 9939 Fax: 39 039 689 9883

JAPAN

Microchip Technology Intl. Inc.
Benex S-1 6F
3-18-20, Shin Yokohama
Kohoku-Ku, Yokohama
Kanagawa 222 Japan
Tel: 81 45 471 6166 Fax: 81 45 471 6122

9/95



MICROCHIP

All rights reserved.

© 1995, Microchip Technology Inc., USA.

Information contained in this publication regarding device applications and the like is intended through suggestion only and may be superseded by updates. No representation or warranty is given and no liability is assumed by Microchip Technology Incorporated with respect to the accuracy or use of such information, or infringement of patents or other intellectual property rights arising from such use or otherwise. Use of Microchip's products as critical components in life support systems is not authorized except with express written approval by Microchip. No licenses are conveyed, implicitly or otherwise, under any intellectual property rights. The Microchip logo and name are registered trademarks of Microchip Technology Inc. All rights reserved. All other trademarks mentioned herein are the property of their respective companies.