

SST502 SERIES

CURRENT REGULATING DIODES

FEATURES	
SECOND SOURCE FOR SILICONIX SST502 SERIES	
WIDE CURRENT RANGE	0.43 to 4.7mA
BIASING NOT REQUIRED	$V_{GS} = 0V$
ABSOLUTE MAXIMUM RATINGS¹	
@ 25 °C (unless otherwise stated)	
Maximum Temperatures	
Storage Temperature	-55 to 150°C
Junction Operating Temperature	-55 to 135°C
Maximum Power Dissipation	
Continuous Power Dissipation	350mW
Maximum Currents	
Forward Current	20mA
Reverse Current	50mA
Maximum Voltages	
Peak Operating Voltage	$P_{OV} = 50V$

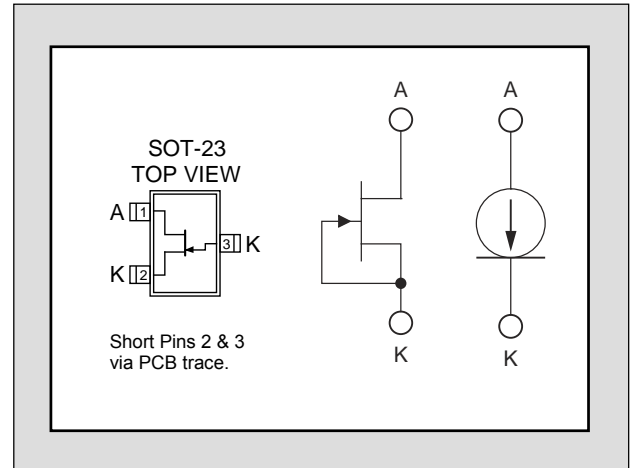

COMMON ELECTRICAL CHARACTERISTICS @ 25 °C (unless otherwise stated)

SYMBOL	CHARACTERISTIC	MIN	TYP	MAX	UNITS	CONDITIONS
P_{OV}	Peak Operating Voltage ²	45			V	$I_F = 1.1I_{F(max)}$
V_R	Reverse Voltage		0.8		V	$I_R = 1mA$
C_F	Forward Capacitance		1.5		pF	$V_F = 25V, f = 1MHz$

SPECIFIC ELECTRICAL CHARACTERISTICS @ 25 °C (unless otherwise stated)

PART	Forward Current ³ I_F			Dynamic Impedance ⁴ Z_d		Knee Impedance Z_k	Limiting Voltage ⁵ V_L	
	$V_F = 25V$			$V_F = 25V$		$V_F = 6V$	$I_F = 0.8I_{F(min)}$	
	MIN	NOM	MAX	MIN	TYP	TYP	TYP	MAX
SST502	0.344	0.43	0.516	1.0	2.7	0.7	1.5	0.6
SST503	0.448	0.56	0.672	0.7	2.0	0.5	1.7	0.7
SST504	0.600	0.75	0.900	0.5	1.5	0.4	1.9	0.8
SST505	0.800	1.00	1.200	0.4	1.0	0.3	2.1	0.9
SST506	1.120	1.40	1.680	0.3	0.8	0.2	2.5	1.1
SST507	1.440	1.80	2.160	0.2	0.6	0.12	2.8	1.3
SST508	1.900	2.40	2.900	0.1	0.4	0.08	3.1	1.5
SST509	2.400	3.00	3.600	0.09	0.3	0.06	3.5	1.7
SST510	2.900	3.60	4.300	0.08	0.3	0.04	3.9	1.9
SST511	3.800	4.70	5.600	0.07	0.2	0.03	4.2	2.1

V-I CHARACTERISTICS CURRENT REGULATING DIODE

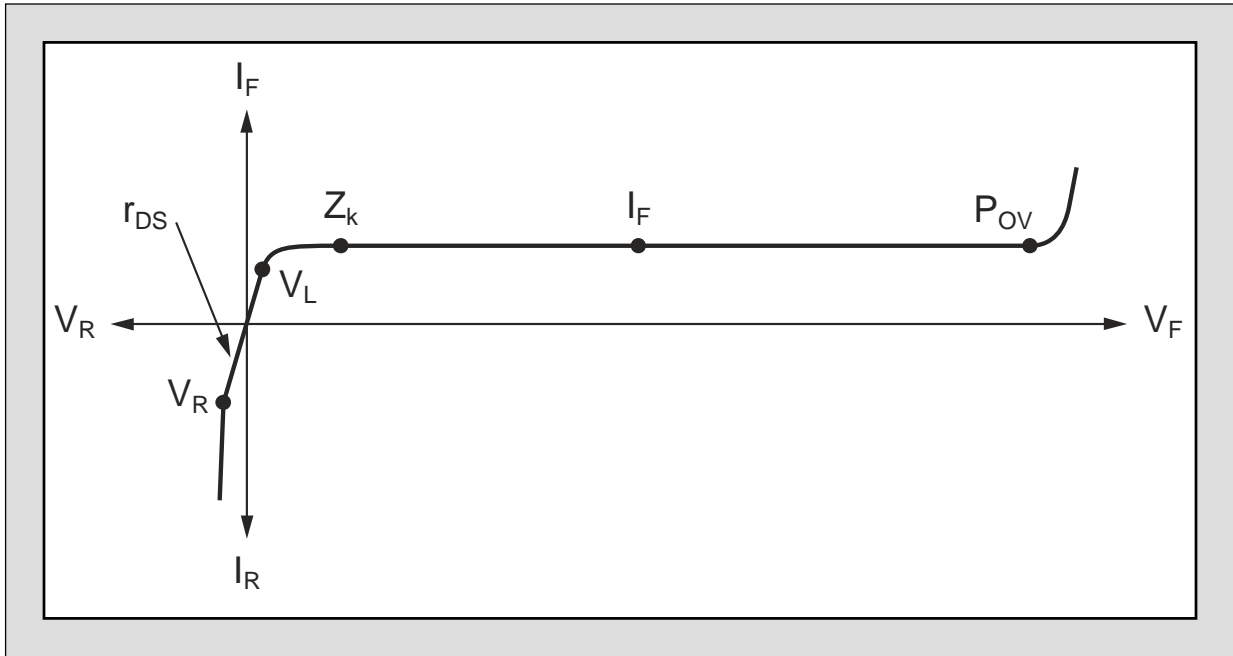

PACKAGING DETAILS

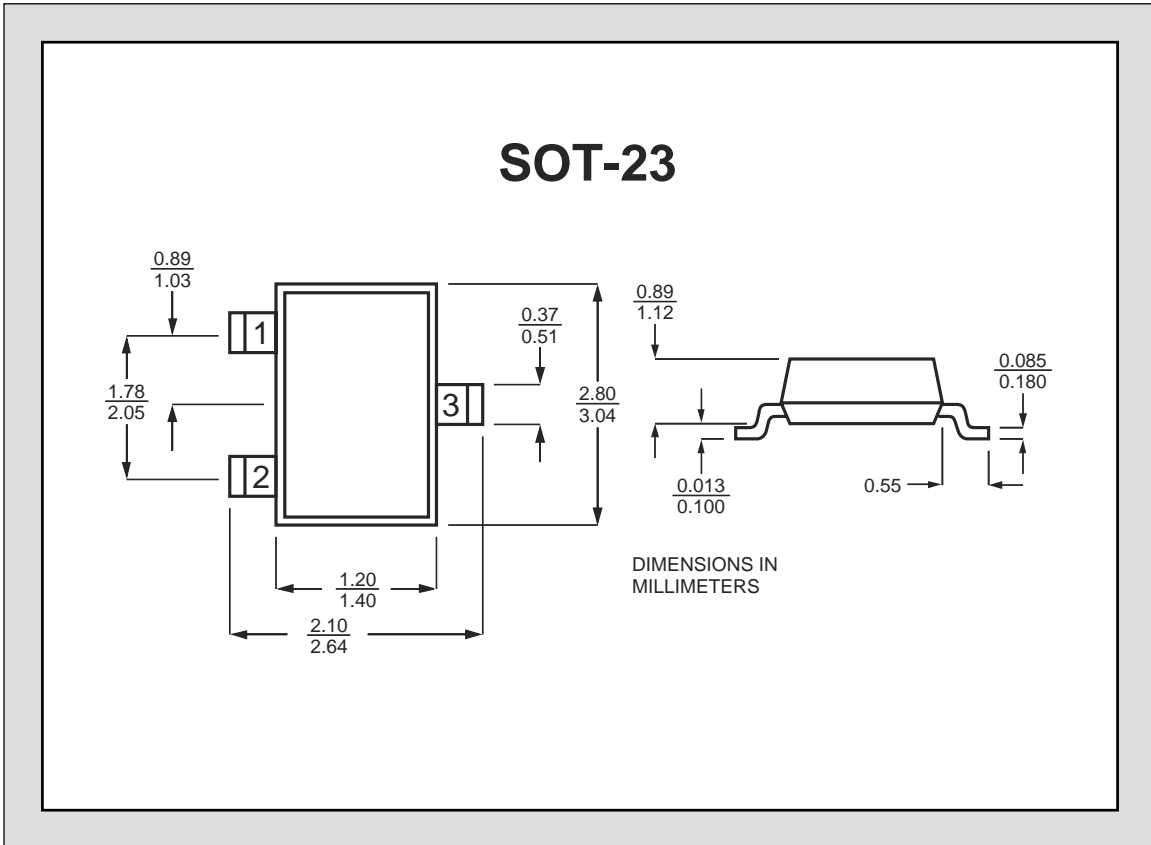

1. Absolute maximum ratings are limiting values above which serviceability may be impaired.
2. Pulsed, $t = 2\text{ms}$. Maximum V_F where $I_F < 1.1I_{F(\text{max})}$.
3. Pulsed, $t = 2\text{ms}$. Continuous currents may vary.
4. Pulsed, $t = 2\text{ms}$. Continuous impedances may vary.
5. Min V_F required to ensure $I_F = 0.8I_{F(\text{min})}$.

Information furnished by Linear Integrated Systems is believed to be accurate and reliable. However, no responsibility is assumed for its use; nor for any infringement of patents or other rights of third parties which may result from its use. No license is granted by implication or otherwise under any patent or patent rights of Linear Integrated Systems.