

# Registered Hex TTL/PECL Translator

The MC10/100H606 is a 6-bit, registered, single supply TTL to PECL translator. The device features differential PECL outputs as well as a choice between either a differential PECL clock input or a TTL clock input. The asynchronous master reset control is a PECL level input.

With its differential PECL outputs and TTL inputs the H606 device is ideally suited for the transmit function of a HPPI bus type board-to-board interface application. The on chip registers simplify the task of synchronizing the data between the two boards.

The device is available in either ECL standard: the MECL™ 10H device is compatible with MECL 10KH logic levels, with a V<sub>CC</sub> of +5 volts; while the 100H device is compatible with 100K logic levels, with a V<sub>CC</sub> of +5 volts.

- Differential 50Ω ECL Outputs
- Choice Between Differential PECL or TTL Clock Input
- Single Power Supply
- Multiple Power and Ground Pins to Minimize Noise

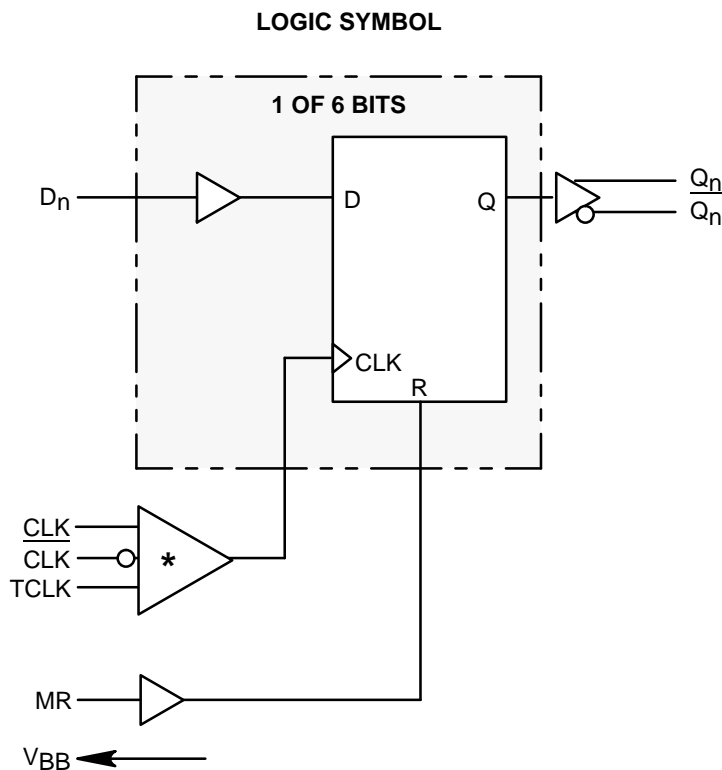

- \* 1. When using PECL inputs, TCLK must be tied to ground (0V).  
 2. When using only one PECL input, the unused PECL input must be tied to V<sub>BB</sub>, and TCLK must be tied to ground (0V).  
 3. When using TCLK, both PECL inputs must be tied to ground (0V).

## MC10H606 MC100H606

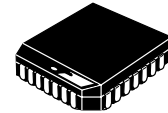

**FN SUFFIX**  
PLASTIC PACKAGE  
CASE 776-02

### PIN NAMES

PIN	FUNCTION
D0-D5	TTL Data Inputs
CLK, CLK	Differential PECL Clock Input
TCLK	TTL Clock Input
MR	PECL Master Reset Input
Q0-Q5	True PECL Outputs
Q0-Q5	Inverted PECL Outputs
V <sub>CCE</sub>	PECL V <sub>CC</sub> (+5.0V)
V <sub>CCT</sub>	TTL V <sub>CC</sub> (+5.0V)
GND	TTL/PECL Ground

### TRUTH TABLE

D <sub>n</sub>	MR	TCLK/CLK	Q <sub>n+1</sub>
L	L	Z	L
H	L	Z	H
X	H	X	L

Z = LOW to HIGH Transition

### Pinout: 28-Lead PLCC (Top View)

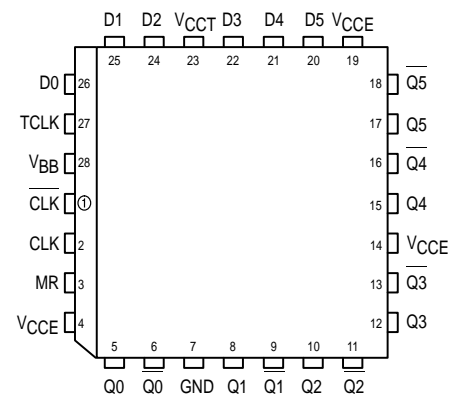

MECL 10H is a trademark of Motorola, Inc.



# MC10H606 MC100H606

## DC CHARACTERISTICS ( $V_{CCT} = V_{CCE} = 5.0V \pm 5\%$ )

Symbol	Characteristic	$T_A = 0^\circ C$			$T_A = +25^\circ C$			$T_A = +85^\circ C$			Unit	Condition
		Min	Typ	Max	Min	Typ	Max	Min	Typ	Max		
$I_{CCTL}$	Supply Current		18	30		18	30		18	30	mA	Outputs LOW
$I_{CCTH}$	Supply Current		13	25		13	25		13	25	mA	Outputs HIGH
$I_{GND}$	Supply Current		75	90		75	90		75	95	mA	

## TTL DC CHARACTERISTICS ( $V_{CCT} = V_{CCE} = 5.0V \pm 5\%$ )

Symbol	Characteristic	$T_A = 0^\circ C$		$T_A = 25^\circ C$		$T_A = 85^\circ C$		Unit	Condition
		Min	Max	Min	Max	Min	Max		
$V_{IH}$	Input HIGH Voltage	2.0		2.0		2.0		V	
$V_{IL}$	Input LOW Voltage		0.8		0.8		0.8	V	
$V_{IK}$	Input Clamp Voltage		-1.2		-1.2		-1.2	V	$I_{IN} = -18mA$
$I_{IH}$	Input HIGH Current		20 100		20 100		20 100	V	$V_{IN} = 2.7V$ $V_{IN} = 7.0V$
$I_{IL}$	Input LOW Current		-0.6		-0.6		-0.6	mA	$V_{IN} = 0.5V$

## 10H PECL DC CHARACTERISTICS ( $V_{CCT} = V_{CCE} = 5.0V \pm 5\%$ )

Symbol	Characteristic	$T_A = 0^\circ C$		$T_A = 25^\circ C$		$T_A = 85^\circ C$		Unit	Condition
		Min	Max	Min	Max	Min	Max		
$I_{INH}$	Input HIGH Current		255		145		145	$\mu A$	
$I_{INL}$	Input LOW Current		0.5		0.5		0.5	$\mu A$	
$V_{IH}$	Input HIGH Voltage (Note 1.)	3830	4160	3870	4190	3930	4280	mV	$V_{CCT} = 5.0V$
$V_{IL}$	Input LOW Voltage (Note 1.)	3050	3520	3050	3520	3050	3555	mV	$V_{CCT} = 5.0V$
$V_{OH}$	Output HIGH Voltage (Note 1.)	3980	4160	4020	4190	4080	4270	mV	$V_{CCT} = 5.0V$
$V_{OL}$	Output LOW Voltage (Note 1.)	3050	3370	3050	3370	3050	3400	mV	$V_{CCT} = 5.0V$
$V_{BB}$	Output Bias Voltage (Note 1.)	3600	3710	3630	3730	3670	3790	mV	$V_{CCT} = 5.0V$

1. PECL  $V_{IL}$ ,  $V_{IH}$ ,  $V_{OL}$ ,  $V_{OH}$ ,  $V_{BB}$  are given for  $V_{CCT} = V_{CCE} = 5.0V$  and will vary 1:1 with the power supply.

## 100H PECL DC CHARACTERISTICS ( $V_{CCT} = V_{CCE} = 5.0V \pm 5\%$ )

Symbol	Characteristic	$T_A = 0^\circ C$		$T_A = 25^\circ C$		$T_A = 85^\circ C$		Unit	Condition
		Min	Max	Min	Max	Min	Max		
$I_{INH}$	Input HIGH Current		255		145		145	$\mu A$	
$I_{INL}$	Input LOW Current		0.5		0.5		0.5	$\mu A$	
$V_{IH}$	Input HIGH Voltage (Note 1.)	3835	4120	3835	4120	3835	4120	mV	$V_{CCT} = 5.0V$
$V_{IL}$	Input LOW Voltage (Note 1.)	3190	3525	3190	3525	3190	3525	mV	$V_{CCT} = 5.0V$
$V_{OH}$	Output HIGH Voltage (Note 1.)	3975	4120	3975	4120	3975	4120	mV	$V_{CCT} = 5.0V$
$V_{OL}$	Output LOW Voltage (Note 1.)	3190	3380	3190	3380	3190	3380	mV	$V_{CCT} = 5.0V$
$V_{BB}$	Output Bias Voltage (Note 1.)	3600	3720	3600	3720	3600	3720	mV	$V_{CCT} = 5.0V$

1. PECL  $V_{IL}$ ,  $V_{IH}$ ,  $V_{OL}$ ,  $V_{OH}$ ,  $V_{BB}$  are given for  $V_{CCT} = V_{CCE} = 5.0V$  and will vary 1:1 with the power supply.

AC CHARACTERISTICS ( $V_{CC} = V_{CE} = 5.0V \pm 5\%$ )

Symbol	Characteristic	$T_A = 0^\circ\text{C}$			$T_A = +25^\circ\text{C}$			$T_A = +85^\circ\text{C}$			Unit	Condition
		Min	Typ	Max	Min	Typ	Max	Min	Typ	Max		
t <sub>PD</sub>	Propagation Delay TCLK++	1.75		3.75	1.75	3.00	3.75	1.75		3.75	ns	CL = 50pF
t <sub>PD</sub>	Propagation Delay TCLK+-	1.75		3.75	1.75	3.00	3.75	1.75		3.75	ns	CL = 50pF
t <sub>PD</sub>	Propagation Delay CLK++	1.50		3.50	1.50	2.50	3.50	1.50		3.50	ns	CL = 50pF
t <sub>PD</sub>	Propagation Delay CLK+-	1.50		3.50	1.50	2.50	3.50	1.50		3.50	ns	CL = 50pF
t <sub>PD</sub>	Propagation Delay MR+-	1.50		3.50	1.50	2.50	3.50	1.75		3.75	ns	CL = 50pF
t <sub>SKEW</sub>	Device Skew Part-to-Part Within Device			2.0 0.5		1.0 0.3	2.0 0.5			2.0 0.5	ns	CL = 50pF
t <sub>S</sub>	Setup Time	1.5	0.5		1.5	0.5		1.5	0.5		ns	CL = 50pF
t <sub>H</sub>	Hold Time	1.5	0.5		1.5	0.5		1.5	0.5		ns	CL = 50pF
t <sub>PW</sub>	Minimum Pulse Width CLK	1.5			1.5	1.0		1.5			ns	CL = 50pF
t <sub>PW</sub>	Minimum Pulse Width MR	1.5			1.5			1.5			ns	CL = 50pF
t <sub>r</sub>	Rise Time			2.0		1.0	2.0			2.0	ns	CL = 50pF
t <sub>f</sub>	Fall Time			2.0		1.0	2.0			2.0	ns	CL = 50pF
t <sub>RES/REC</sub>	Reset/Recovery Time	2.5	2.0		2.5	2.0		2.5	2.0		ns	CL = 50pF

OUTLINE DIMENSIONS

FN SUFFIX  
 PLASTIC PLCC PACKAGE  
 CASE 776-02  
 ISSUE D

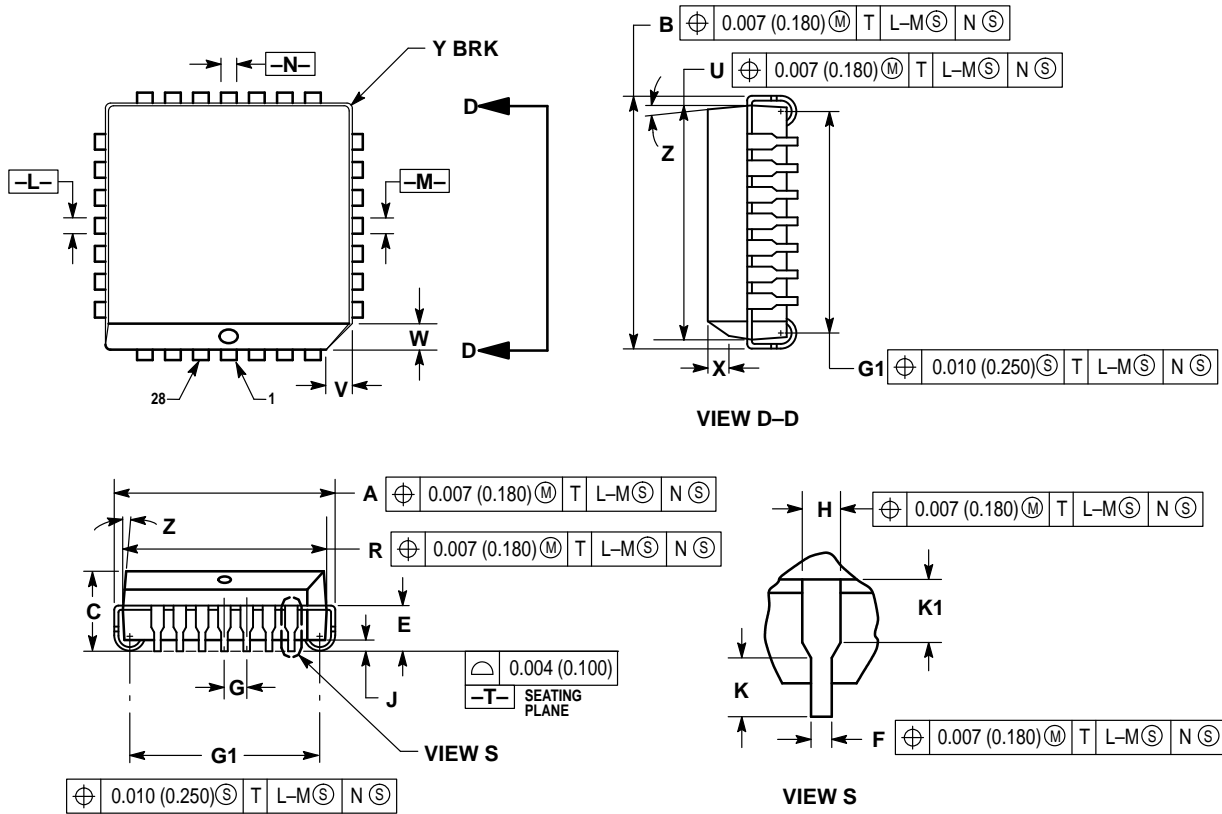

NOTES:

- DATUMS -L-, -M-, AND -N- DETERMINED WHERE TOP OF LEAD SHOULDER EXITS PLASTIC BODY AT MOLD PARTING LINE.
- DIMENSION G1, TRUE POSITION TO BE MEASURED AT DATUM -T-, SEATING PLANE.
- DIMENSIONS R AND U DO NOT INCLUDE MOLD FLASH. ALLOWABLE MOLD FLASH IS 0.010 (0.250) PER SIDE.
- DIMENSIONING AND TOLERANCING PER ANSI Y14.5M, 1982.
- CONTROLLING DIMENSION: INCH.
- THE PACKAGE TOP MAY BE SMALLER THAN THE PACKAGE BOTTOM BY UP TO 0.012 (0.300). DIMENSIONS R AND U ARE DETERMINED AT THE OUTERMOST EXTREMES OF THE PLASTIC BODY EXCLUSIVE OF MOLD FLASH, TIE BAR BURRS, GATE BURRS AND INTERLEAD FLASH, BUT INCLUDING ANY MISMATCH BETWEEN THE TOP AND BOTTOM OF THE PLASTIC BODY.
- DIMENSION H DOES NOT INCLUDE DAMBAR PROTRUSION OR INTRUSION. THE DAMBAR PROTRUSION(S) SHALL NOT CAUSE THE H DIMENSION TO BE GREATER THAN 0.037 (0.940). THE DAMBAR INTRUSION(S) SHALL NOT CAUSE THE H DIMENSION TO BE SMALLER THAN 0.025 (0.635).

DIM	INCHES		MILLIMETERS	
	MIN	MAX	MIN	MAX
A	0.485	0.495	12.32	12.57
B	0.485	0.495	12.32	12.57
C	0.165	0.180	4.20	4.57
E	0.090	0.110	2.29	2.79
F	0.013	0.019	0.33	0.48
G	0.050 BSC		1.27 BSC	
H	0.026	0.032	0.66	0.81
J	0.020	—	0.51	—
K	0.025	—	0.64	—
R	0.450	0.456	11.43	11.58
U	0.450	0.456	11.43	11.58
V	0.042	0.048	1.07	1.21
W	0.042	0.048	1.07	1.21
X	0.042	0.056	1.07	1.42
Y	—	0.020	—	0.50
Z	2°		10°	
G1	0.410	0.430	10.42	10.92
K1	0.040	—	1.02	—

Motorola reserves the right to make changes without further notice to any products herein. Motorola makes no warranty, representation or guarantee regarding the suitability of its products for any particular purpose, nor does Motorola assume any liability arising out of the application or use of any product or circuit, and specifically disclaims any and all liability, including without limitation consequential or incidental damages. "Typical" parameters which may be provided in Motorola data sheets and/or specifications can and do vary in different applications and actual performance may vary over time. All operating parameters, including "Typicals" must be validated for each customer application by customer's technical experts. Motorola does not convey any license under its patent rights nor the rights of others. Motorola products are not designed, intended, or authorized for use as components in systems intended for surgical implant into the body, or other applications intended to support or sustain life, or for any other application in which the failure of the Motorola product could create a situation where personal injury or death may occur. Should Buyer purchase or use Motorola products for any such unintended or unauthorized application, Buyer shall indemnify and hold Motorola and its officers, employees, subsidiaries, affiliates, and distributors harmless against all claims, costs, damages, and expenses, and reasonable attorney fees arising out of, directly or indirectly, any claim of personal injury or death associated with such unintended or unauthorized use, even if such claim alleges that Motorola was negligent regarding the design or manufacture of the part. Motorola and  are registered trademarks of Motorola, Inc. Motorola, Inc. is an Equal Opportunity/Affirmative Action Employer.

**How to reach us:**

**USA/EUROPE/Locations Not Listed:** Motorola Literature Distribution;  
P.O. Box 5405, Denver, Colorado 80217. 1-800-441-2447

**Mfax™:** RMFAX0@email.sps.mot.com – TOUCHTONE 602-244-6609  
**INTERNET:** <http://Design-NET.com>

**JAPAN:** Nippon Motorola Ltd.; Tatsumi-SPD-JLDC, 6F Seibu-Butsuryu-Center,  
3-14-2 Tatsumi Koto-Ku, Tokyo 135, Japan. 03-81-3521-8315

**ASIA/PACIFIC:** Motorola Semiconductors H.K. Ltd.; 8B Tai Ping Industrial Park,  
51 Ting Kok Road, Tai Po, N.T., Hong Kong. 852-26629298

