

INTRODUCTION

S6A0072 is a dot matrix LCD driver & controller IC which is fabricated by low power CMOS technology. It is capable of displaying 1-line 16 characters or 2-line 8 characters with 5×8 dots format.

FUNCTIONS

Character type dot matrix LCD driver & controller

- Easy interface with 4-bit or 8-bit MPU.
- Internal driver: 16 common and 40 segment signal output.
- Display character pattern: 5×8 dots format (240 kinds)
- Direct programming of the special character patterns by character generator RAM
- Mask option for programming customer character patterns
- Various instruction functions
- Automatic power on reset

FEATURES

- Internal Memory
 - Character Generator ROM (CGROM): 9600 bits (240 characters \times 5×8 dot)
 - Character Generator RAM (CGRAM): 160 bits (4 characters \times 5×8 dot)
 - Display Data RAM (DDRAM): 128 bits (16 characters \times 8bits)
- Low power operation
 - Power supply voltage range: 2.7 to 5.5V (VDD)
 - LCD drive voltage range: 3.0 to 11.0 (VDD-V5)
- CMOS process
- Duty cycle: 1/16
- Built-in oscillator
- Low power consumption
- Internal divide resistor for LCD driving voltage
- COG available

BLOCK DIAGRAM

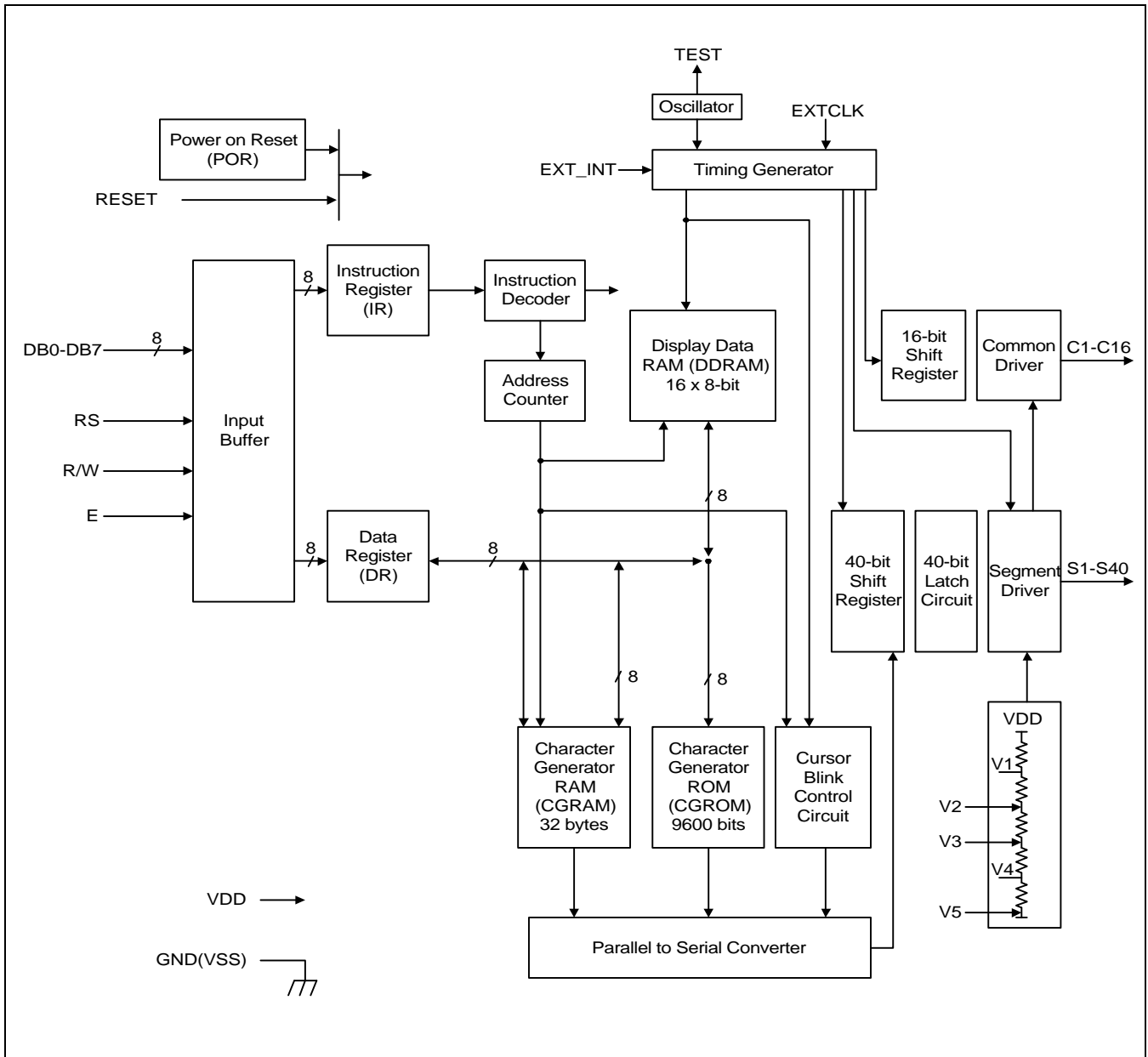

PAD DIAGRAM

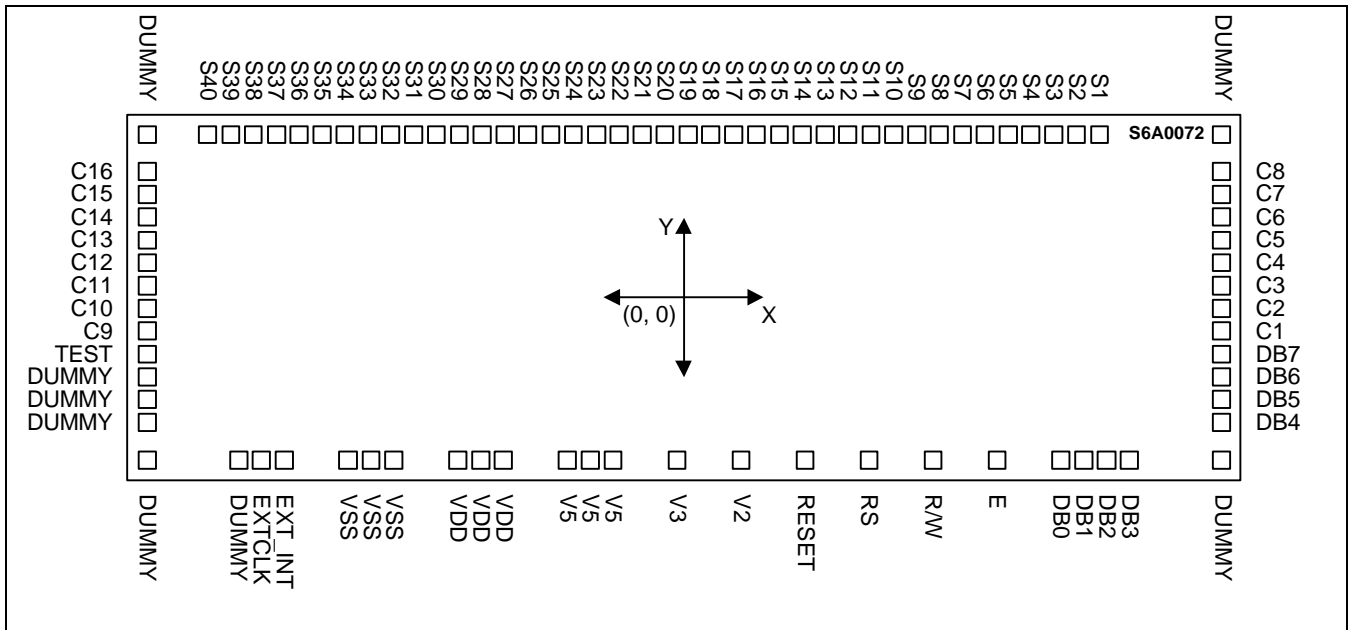

S6A0072

Chip Size: 7600 × 2160 μm

Pad pitch: min. 125 μm

Chip thickness 675 μm

AI Pad Specifications

AL pad size on Y side: 87 × 94 μm

AL pad size on X side: 94 × 87 μm

Au Bump Specifications

Bump size on Y side: 77 × 84 μm

Bump size on X side: 84 × 77 μm

Bump height: 18 ± 1 μm

PAD CENTER COORDINATES

Unit: um

Pad No.	Pad Name	Coordinate		Pad No.	Pad Name	Coordinate		Pad No.	Pad Name	Coordinate	
		X	Y			X	Y			X	Y
1	DUMMY	-3642	-881	31	C3	3643	64	61	S24	-455	923
2	DUMMY	-3032	-881	32	C4	3643	189	62	S25	-580	923
3	EXTCLK	-2632	-881	33	C5	3643	314	63	S26	-705	923
4	EXT_INT	-2232	-881	34	C6	3643	439	64	S27	-830	923
5	VSS	-1832	-881	35	C7	3643	564	65	S28	-955	923
6	VSS	-1707	-881	36	C8	3643	689	66	S29	-1080	923
7	VSS	-1582	-881	37	DUMMY	3643	923	67	S30	-1205	923
8	VDD	-1182	-881	38	S1	2464	923	68	S31	-1330	923
9	VDD	-1057	-881	39	S2	2329	923	69	S32	-1455	923
10	VDD	-932	-881	40	S3	2204	923	70	S33	-1580	923
11	V5	-532	-881	41	S4	2079	923	71	S34	-1705	923
12	V5	-407	-881	42	S5	1954	923	72	S35	-1830	923
13	V5	-282	-881	43	S6	1829	923	73	S36	-1955	923
14	V3	117	-881	44	S7	1704	923	74	S37	-2080	923
15	V2	517	-881	45	S8	1579	923	75	S38	-2205	923
16	RESETB	917	-881	46	S9	1454	923	76	S39	-2330	923
17	RS	1317	-881	47	S10	1329	923	77	S40	-2463	923
18	R/W	1717	-881	48	S11	1204	923	78	DUMMY	-3642	923
19	E	2117	-881	49	S12	1079	923	79	C16	-3643	689
20	DB0	2521	-881	50	S13	954	923	80	C15	-3643	564
21	DB1	2697	-881	51	S14	829	923	81	C14	-3643	439
22	DB2	2871	-881	52	S15	704	923	82	C13	-3643	314
23	DB3	3047	-881	53	S16	579	923	83	C12	-3643	189
24	DUMMY	3643	-881	54	S17	454	923	84	C11	-3643	64
25	DB4	3643	-717	55	S18	329	923	85	C10	-3643	-60
26	DB5	3643	-591	56	S19	204	923	86	C9	-3643	-184
27	DB6	3643	-467	57	S20	71	923	87	TEST	-3643	-341
28	DB7	3643	-341	58	S21	-70	923	88	DUMMY	-3643	-467
29	C1	3643	-184	59	S22	-205	923	89	DUMMY	-3643	-592
30	C2	3643	-60	60	S23	-330	923	90	DUMMY	-3643	-717

PIN DESCRIPTION

Pin	Input/Output	Name	Description	Interface
VDD	Power	Power supply & LCD bias pin	for logical circuit (+3V, +5V)	Power supply
VSS (GND)			0V (GND)	
V2, V3, V5			Bias voltage level for LCD driving	
S1 - S40	Output	Segment output	Segment signal output for LCD driving	LCD
C1 - C16	Input	Common output	Common signal output for LCD driving	LCD
EXTCLK	Input	External clock Input	When using external clock, used as clock input pin. When using internal oscillator, connect to VDD or VSS.	External clock
EXT_INT	Input	External/internal oscillator clock select	When EXT_INT = "High", external clock is used. When "Low", internal oscillator is used.	VDD/VSS
RS	Input	Register select	Used as register selection input. When RS = "High", Data register is selected. When RS = "Low", Instruction register is selected.	MPU
R/W	Input	Read/write	Used as read/write selection input. When R/W = "High", read operation. When R/W = "Low", write operation.	
E	Input	Read/write enable	Used as read/write enable signal.	
DB0-DB3	Input/Output	Data bus 0 - 7	When 8-bit bus mode, used as low order bi-directional data bus. During 4-bit bus mode open these pins.	
DB4-DB7			When 8-bit bus mode, used as high order bi-directional data bus. In case of 4-bit bus mode, used as both high and low order. DB7 is used for busy flag output during read instruction operation.	
RESETB	Input	Reset	If it is necessary to initialize the system by hardware, force "Low", level signal to this terminal about 1.2ms.	
TEST	Output	Test pin	Internal oscillator test pin. Open this pin.	Open

FUNCTION DESCRIPTION

SYSTEM INTERFACE

This chip consists of two kinds of interface type with MPU: 4-bit bus and 8-bit bus. 4-bit bus and 8-bit bus is selected by DL bit of function set in the instruction register. During read or write operation, two 8-bit registers are used. One is the data register (DR), the other is the instruction register (IR). The data register (DR) is used as a temporary data storage place for being written into or read from DDRAM/CGRAM, target RAM is selected by RAM address setting instruction. Each internal operation, reading from or writing into RAM, is done automatically. Thus, after MPU reads DR data, the data in the next DDRAM/CGRAM address is transferred into DR automatically. Also after MPU writes data to DR, the data in DR is transferred into DDRAM/CGRAM automatically. The Instruction register (IR) is used only to store instruction code transferred from MPU. MPU cannot read data from instruction register. The register selection depends on RS input pin setting in both 4-bit bus mode.

Table 1. Various Kinds Of Operations According to RS and R/W Bits

RS	R/W	Operation
0	0	Instruction write operation (MPU writes Instruction code into IR)
0	1	Read busy flag (DB7) and address counter (DB0 - DB6)
1	0	Data write operation (MPU writes data into DR)
1	1	Data read operation (MPU reads data from DR)

BUSY FLAG (BF)

BF = "High" indicates that the internal operation is being processed. So during this time the next instruction cannot be accepted. BF can be read, when RS = Low and R/W = High (Read instruction Operation), through DB7 port.

Before executing the next instruction, be sure that BF is not High.

ADDRESS COUNTER (AC)

Address Counter (AC) stores the address of DDRAM/CGRAM that are transferred from IR. After writing into (reading from) DDRAM/CGRAM data, AC is increased (decreased) by 1 automatically. When RS = "Low", and R/W = "High", AC value can be read through DB0 - DB6 ports.

DISPLAY DATA RAM (DDRAM)

DDRAM stores 8bits character code in CGROM/CGRAM and its maximum number is 16 (16 Characters). DDRAM address is set by the address counter (AC) as hexadecimal number.

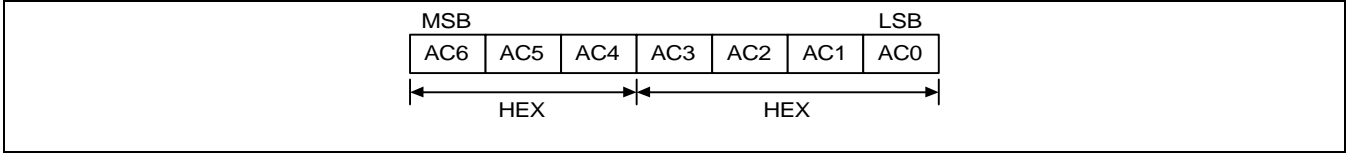

The relations of DDRAM address and display position is as follows.

1) DDRAM Addressing Mode 0 (A = 0)-

In this addressing mode, the address range of DDRAM is 00H - 0FH.

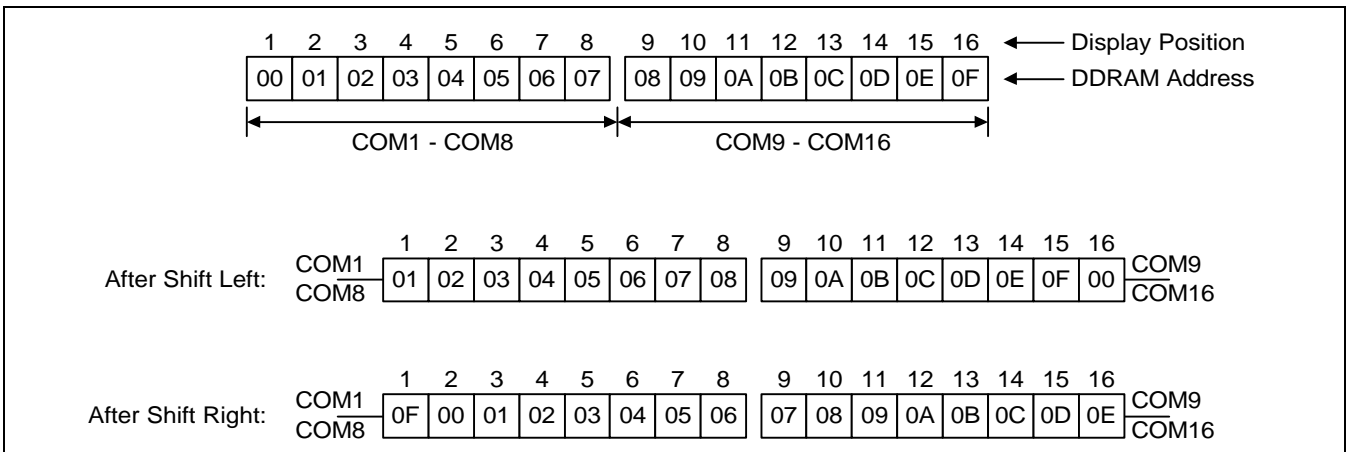

2) DDRAM Addressing Mode 1 (A = 1)

In this addressing mode, the address range of DDRAM is 00H - 07H and 40H - 47H.

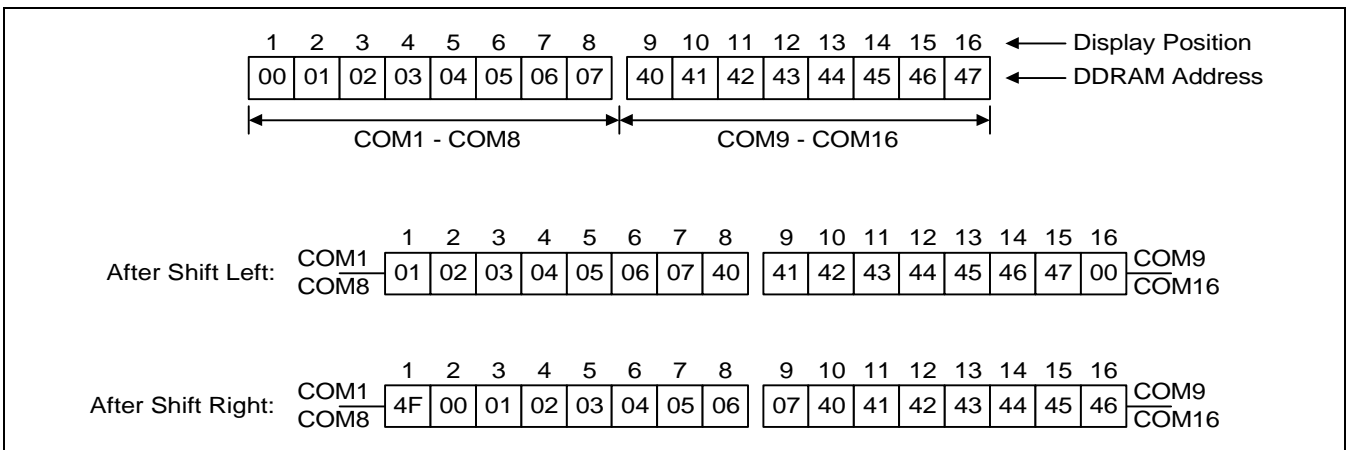

CHARACTER GENERATOR RAM (CGRAM)

CGRAM is used for user defined character pattern. The format of the character pattern is 5×7 dots except for the cursor position and has a maximum of 4 characters. To use the character pattern in CGRAM write the character code into DDRAM as shown in table 2.

Table 2. Relationship Between Character Code (DDRAM) and Character Pattern (CGRAM)

Character Code (DDRAM data)								CGRAM Address					CGRAM Data							Pattern Number	
D7	D6	D5	D4	D3	D2	D1	D0	A4	A3	A2	A1	A0	P7	P6	P5	P4	P3	P2	P1		P0
0	0	0	0	*	*	0	0	0	0	0	0	0	x	x	x	0	1	1	1	0	Pattern 1
								0	0	0	0	1				1	0	0	0	1	
								0	0	0	1	0				1	0	0	0	1	
								0	0	0	1	1				1	1	1	1	1	
								0	0	1	0	0				1	0	0	0	1	
								0	0	1	0	1				1	0	0	0	1	
								0	0	1	1	0				1	0	0	0	1	
								0	0	1	1	1				0	0	0	0	0	←Cursor position
0	0	0	0	*	*	1	1	1	1	0	0	0	x	x	x	1	1	1	1	0	Pattern 4
								1	1	0	0	1				1	0	0	0	1	
								1	1	0	1	0				1	0	0	0	1	
								1	1	0	1	1				1	0	0	0	1	
								1	1	1	0	0				1	0	0	0	1	
								1	1	1	0	1				1	0	0	0	1	
								1	1	1	1	0				1	1	1	1	0	
								1	1	1	1	1				0	0	0	0	0	←Cursor position

NOTE: "*" don't care.

CHARACTER GENERATOR ROM (CGROM)

CGROM generates 5×8 character pattern from character generate code in DDRAM. CGROM has 5×8 -dot 240 character pattern including cursor position. If the data in cursor position bit are high, the data are included to the character pattern. So, the selected positions are always "ON" regardless to cursor position. The relationship between character code and character pattern can be referred to table 5.

TIMING GENERATION CIRCUIT

Timing generation circuit generates clock signals for the internal operations.

LCD DRIVER CIRCUIT

LCD driver circuit has 16 common and 40 segment output signals for LCD driving. Data from CGRAM/CGROM is transferred to 40-bit segment shift register serially, then it is stored to 40-bit segment output latch. When each com is selected by a 16-bit common register, the segment data also outputs through segment driver from 40-bit segment output latch.

CURSOR/BLINK CONTROL CIRCUIT

It controls cursor/blink ON/OFF at the cursor position.

INSTRUCTION DESCRIPTION

OUTLINE

To overcome the speed difference between the internal clock of S6A0072 and the MPU clock, the S6A0072 performs an internal operation by storing control information to IR or DR. The internal operation is determined according to the signal from MPU, composed of read/write and data bus.

Instruction can be divided into four types:

- S6A0072 function set instructions (set display methods, set data length, etc.)
- Address set instructions to internal RAM
- Data transfer instructions with internal RAM
- Others.

The address of internal RAM is automatically increased or decreased by 1.

NOTE: During an internal operation, the busy flag (DB7) is high. Busy flag check must precede the next instruction.
When an MPU program with busy flag (DB7) checking is made, $1/2F_{osc}$ is necessary for executing the next instruction by the falling edge of the "E" signal after the busy flag (DB7) goes to "Low".

Table 3. Instruction Table

Instruction	Instruction Code										Description	Execution Time (fosc = 270kHz)	
	RS	R/W	DB7	DB6	DB5	DB4	DB3	DB2	DB1	DB0			
Test mode	0	0	0	0	0	0	0	0	0	0	0	Device test mode (When 4-bit interface mode) No operation (When 8-bit interface mode)	-
Clear display	0	0	0	0	0	0	0	0	0	0	1	Write "20H" to DDRAM and set DDRAM address to "00H" from AC.	631μs
Return home	0	0	0	0	0	0	0	0	0	1	*	Set DDRAM address to "00H" from AC and return cursor to its original position if shifted. The contents of DDRAM are not changed.	631μs
Entry mode set	0	0	0	0	0	0	0	0	1	I/D	S	Assign cursor moving direction and enable entire display shift.	39μs
Display ON/OFF control	0	0	0	0	0	0	0	1	D	C	B	All display (D), cursor (C), and blinking of cursor position character on/off control bit (B).	39μs
Cursor or display shift	0	0	0	0	0	0	1	S/C	R/L	*	*	Cursor and display shift and their direction control without changing DDRAM data.	39μs
Function set	0	0	0	0	0	1	DL	A	*	M1	M0	Set interface data length (DL), DDRAM addressing mode (A) and COM/SEG output pattern (M0, M1).	39μs
Set CGRAM address	0	0	0	1	*	AC4	AC3	AC2	AC1	AC0		Set CGRAM address in address counter.	39μs
Set DDRAM address	0	0	1	AC6	AC5	AC4	AC3	AC2	AC1	AC0		Set DDRAM address in address counter.	39μs
Read busy flag and Address	DDRAM	0	1	BF	AC6	AC5	AC4	AC3	AC2	AC1	AC0	Whether in internal operation or not can be known by reading BF. The contents of address counter can also be read	0μs
	CGRAM				*	*	AC4	AC3	AC2	AC1	AC0		

Note: "*" don't care.

Table 3. Instruction Table (Continued)

Instruction		Instruction Code										Description	Execution Time (fosc = 270kHz)
		RS	R/W	DB7	DB6	DB5	DB4	DB3	DB2	DB1	DB0		
Write data to RAM	DDRAM	1	0	D7	D6	D5	D4	D3	D2	D1	D0	Write data into internal RAM (DDRAM/CGRAM).	43μs
	CGRAM			*	*	*	D4	D3	D2	D1	D0		
Read data from RAM	DDRAM	1	1	D7	D6	D5	D4	D3	D2	D1	D0	Read data from internal RAM (DDRAM/CGRAM).	43μs
	CGRAM			*	*	*	D4	D3	D2	D1	D0		

Note: "*" don't care.

I/D = 1: Increment,

I/D = 0: Decrement

S = 1: Shift enable,

S = 0: Shift disable

S/C = 1: Display shift,

S/C = 0: Move cursor

R/L = 1: Shift right,

R/L = 0: Shift left

DL = 1: 8-bit interface,

DL = 0: 4-bit interface

A = 0: DDRAM addressing mode 0,

A = 1: DDRAM addressing mode1

M0 = 0: COM/SEG output pattern A,

M0 = 1: COM/SEG output pattern B

M1 = 0: 1 line 16 characters,

M1 = 1: 2 line 8 characters

BF = 1: System is in operation

BF = 0: System is ready

CONTENTS

Test Mode

RS	R/W	DB7	DB6	DB5	DB4	DB3	DB2	DB1	DB0
0	0	0	0	0	0	0	0	0	0

After setting the DL bit to 4-bit data interface mode (DL = 0), writing this code twice makes the system go to test mode. And when 8-bit interface mode (DL = 1) is set, normal function mode is returned. System is unaffected if this code is set in 8-bit interface, other than consuming some time. (37 μ s at fosc = 270kHz)

Clear Display

RS	R/W	DB7	DB6	DB5	DB4	DB3	DB2	DB1	DB0
0	0	0	0	0	0	0	0	0	1

Clear all the display data by writing "20H" (space code of CGROM) to all DDRAM address, and set DDRAM address to "00H" into AC (Address Counter). For this instruction, the CGROM address "20H" has to be set to space code. Shifting of the display position returns it to the original position. Namely, when display data is shifted and cursor or blinking is displayed, bring the cursor to the left edge on first line of the display. It makes entry mode to increment (I/D = 1)

Return Home

RS	R/W	DB7	DB6	DB5	DB4	DB3	DB2	DB1	DB0
0	0	0	0	0	0	0	0	1	*

Set DDRAM address to "00H" into the address counter. Shifting of the display position returns it to the original position. When cursor or blinking is displayed, bring the cursor to the left edge on first line of the display. The data in DDRAM does not change.

Entry Mode Set

RS	R/W	DB7	DB6	DB5	DB4	DB3	DB2	DB1	DB0
0	0	0	0	0	0	0	1	I/D	S

Set the moving direction of cursor and display.

- I/D: Increment/decrement of DDRAM/CGRAM address (cursor or blink)
 When I/D = "High", cursor/blink moves to right and DDRAM address is increased by 1.
 When I/D = "Low", cursor/blink moves to left and DDRAM address is decreased by 1.
- S: Shift of entire display
 When DDRAM read (CGRAM read/write) operation or S = "Low", entire display is not shift.
 If S = "High", and DDRAM write operation, entire display is shifted according to I/D value
 (I/D = "1": shift left, I/D = "0": shift right).

Display ON/OFF Control

RS	R/W	DB7	DB6	DB5	DB4	DB3	DB2	DB1	DB0
0	0	0	0	0	0	1	D	C	B

Control display/cursor/blink ON/OFF 1 bit register.

- D: Display ON/OFF control bit
When D = "High", entire display is turned on.
When D = "Low", entire display is turned off, but display data is remains in DDRAM.
- C: Cursor ON/OFF control bit
When C = "High", cursor is turned on.
When C = "Low", cursor is disappeared in current display, but I/D register preserves its data.
- B: Cursor Blink ON/OFF control bit
When B = "High", cursor blink is on, performs alternately between all high data (black pattern) and display character at the cursor position.
When B = "Low", blink is off.

Cursor or Display Shift

RS	R/W	DB7	DB6	DB5	DB4	DB3	DB2	DB1	DB0
0	0	0	0	0	1	S/C	R/L	*	*

Without writing or reading of display data, shift right/left the cursor position or display. This instruction is used to correct or search display data. (Refer to Table 4) during 2-line mode display, cursor moves to the 2nd line after 8th digit of 1st line. Note that display shift is performed simultaneously in all the line. When displayed data is shifted repeatedly, each line is shifted individually. When display shift is performed, the contents of address counter are not changed.

Table 4. Shift patterns according to S/C and R/L bits

R/C	R/L	Operation
0	0	Shift cursor to the left, AC is decreased by 1
0	1	Shift cursor to the right, AC is increased by 1
1	0	Shift all the display to the left, cursor moves according to the display
1	1	Shift all the display to the right, cursor moves according to the display

Function Set

RS	R/W	DB7	DB6	DB5	DB4	DB3	DB2	DB1	DB0
0	0	0	0	1	DL	A	*	M1	M0

- DL:** Interface data length control bit
 When DL = "High" 8-bit bus mode with MPU.
 When DL = "Low", 4-bit bus mode with MPU. Thus, DL is a signal to select 8-bit or 4-bit bus mode.
 In 4-bit bus mode, the 4-bit data is transferred twice.
- A:** Set the display data addressing mode
 When A = "Low", DDRAM addressing mode 0.
 When A = "High", DDRAM addressing mode 1.
- M0:** Set COM/SEG output rotation
 When M0 = "Low", COM/SEG output rotation mode A.
 When M0 = "High", COM/SEG output rotation mode B.
- M1:** Set display line and character mode
 When M1 = "Low", 1 line 16 character display mode.
 When M1 = "High", 2line 8 character display mode. (refer to application information)

Set CGRAM Address

RS	R/W	DB7	DB6	DB5	DB4	DB3	DB2	DB1	DB0
0	0	0	1	*	AC4	AC3	AC2	AC1	AC0
					MSB			LSB	

Set CGRAM address to AC. This instruction allows the MPU to access CGRAM data for user defined character pattern. Available CGRAM Address is lower 5 bits (DB4 - DB0).

Set DDRAM Address

RS	R/W	DB7	DB6	DB5	DB4	DB3	DB2	DB1	DB0
0	0	1	AC6	AC5	AC4	AC3	AC2	AC1	AC0

Set DDRAM address to AC. This instruction allows the MPU to access DDRAM data. When DDRAM addressing mode 1 (A = 0), DDRAM address is from "00H" - "0FH". In DDRAM addressing mode 2 (A = 1), DDRAM address range of the 1st 8 character is "00H" - "07H", and DDRAM address range of the 2nd 8 character is "40H" - "47H".

Read Busy Flag & Address**DDRAM**

RS	R/W	DB7	DB6	DB5	DB4	DB3	DB2	DB1	DB0
0	0	BF	AC6	AC5	AC4	AC3	AC2	AC1	AC0
			MSB					LSB	

CGRAM

RS	R/W	DB7	DB6	DB5	DB4	DB3	DB2	DB1	DB0
0	0	BF	*	*	AC4	AC3	AC2	AC1	AC0
			MSB					LSB	

This instruction shows whether S6A0072 is in internal operation or not. If the resultant BF is high, The internal operation is in progress and should wait until BF to be low, which by then the next instruction can be performed. In the instruction you can read also the value of address counter.

Write Data to RAM

Write binary 8/5 bit data to DDRAM/CGRAM. The selection of RAM from DDRAM/CGRAM is set by the previous address set instruction (DDRAM address set, CGRAM address set). After writing operation, the address is automatically increased/decreased by 1, according to the entry mode.

Read Data From RAM**DDRAM**

RS	R/W	DB7	DB6	DB5	DB4	DB3	DB2	DB1	DB0
1	0	D7	D6	D5	D4	D3	D2	D1	D0
			MSB					LSB	

CGRAM

RS	R/W	DB7	DB6	DB5	DB4	DB3	DB2	DB1	DB0
1	0	*	*	*	D4	D3	D2	D1	D0
			MSB					LSB	

READ BINARY 8/5 BIT FROM DDRAM/CGRAM

The selection of RAM is set by the previous address set instruction. If the address set instruction of RAM is not performed before this instruction, data that was read first becomes invalid, as the direction of AC is not determined. If RAM data is read several times without RAM address set instruction before read operation, the correct RAM data can be obtained from the second, but the first data would be incorrect, as there is no time margin to transfer the RAM data. In case of DDRAM reading operation, the cursor shift instruction plays the same role as DDRAM address set instruction also transfers RAM data to output data register. After read operation address counter is automatically increased/decreased by 1 according to the entry mode. After CGRAM read operation, the display shift may not be executed correctly.

- In the case of RAM write operation, AC is increased/decreased by 1 like read operation (after this operation). In this time, AC indicates the next address position, but only the previous data can be read by read instruction.

INTERFACE WITH MPU

INTERFACE WITH 8-BIT MPU

With 8-bit interfacing data length transfer is performed at a time through 8 ports, from DB0 - DB7. Example of timing sequence is shown below.

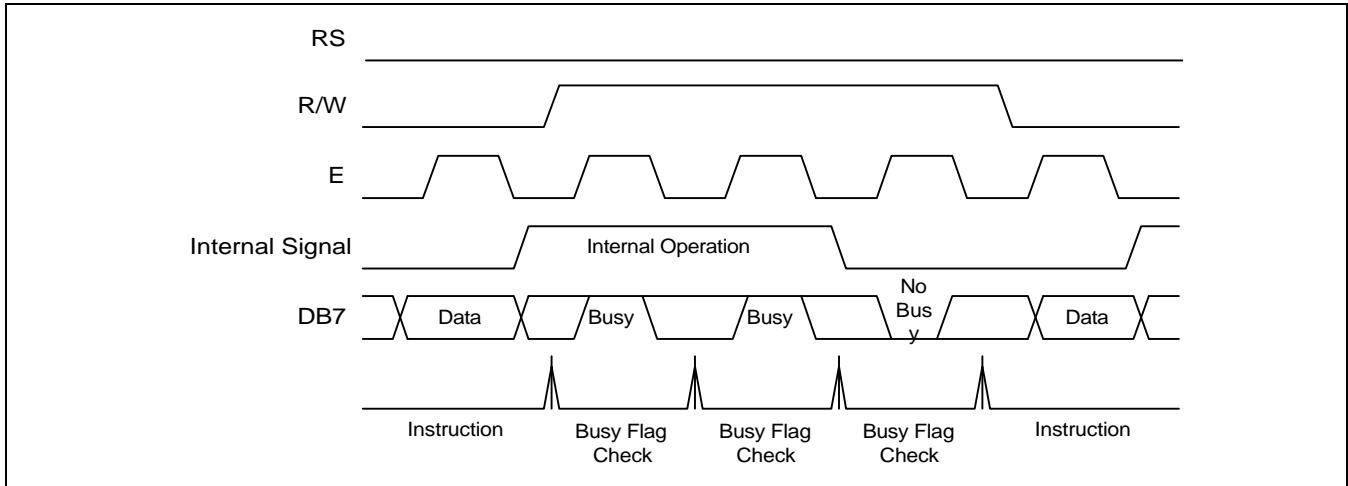

Figure 1. Example of 8-bit Bus Mode Timing Diagram

INTERFACE WITH 4-BIT MPU

When interfacing data length are 4-bit, only 4 ports, from DB4 - DB7, are used as data bus. At first higher 4-bit (in case of 8-bit bus mode, the contents of DB4-DB7) are transferred, then the lower 4-bit (in case of 8-bit bus mode, the contents of DB0-DB3) are transferred. So transfer is performed twice. Busy Flag outputs "High" after the second transfer are ended. Example of timing sequence is shown below.

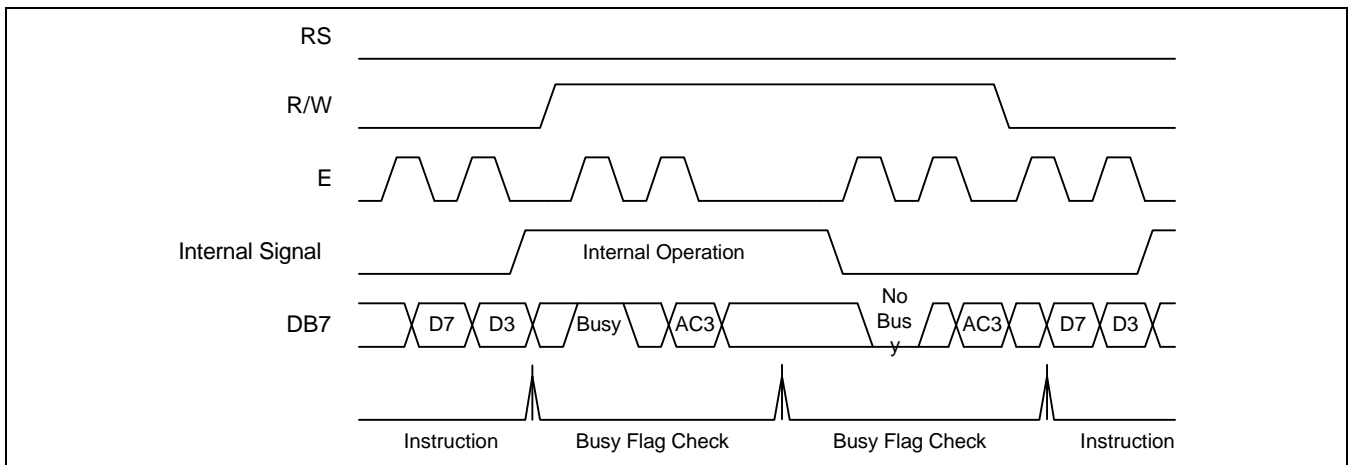
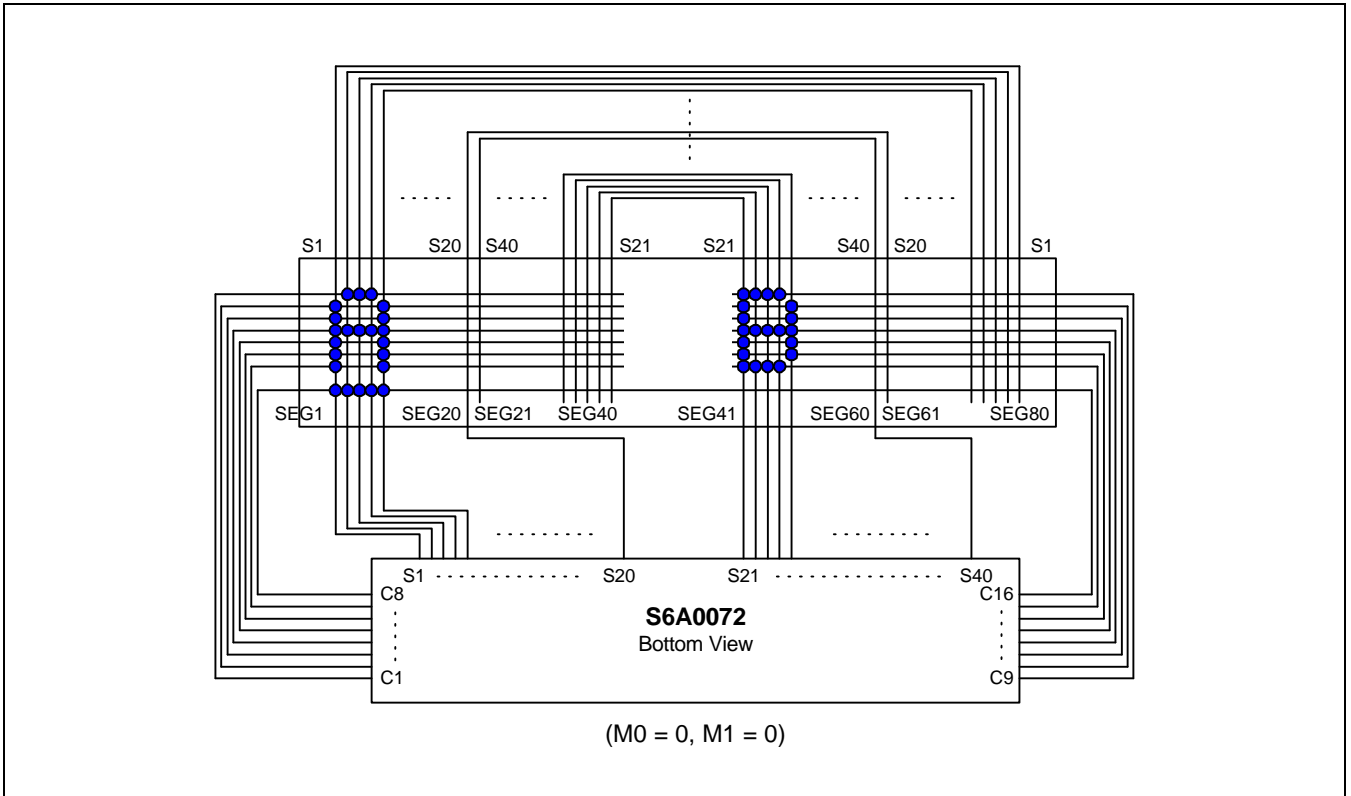

Figure 2. Example of 4-bit Bus Mode Timing Diagram

APPLICATION INFORMATION

COM/SEG OUTPUT ROTATION MODE A

DDRAM Address Mode 0 (A = 0)



DDRAM Address Mode 1 (A = 1)

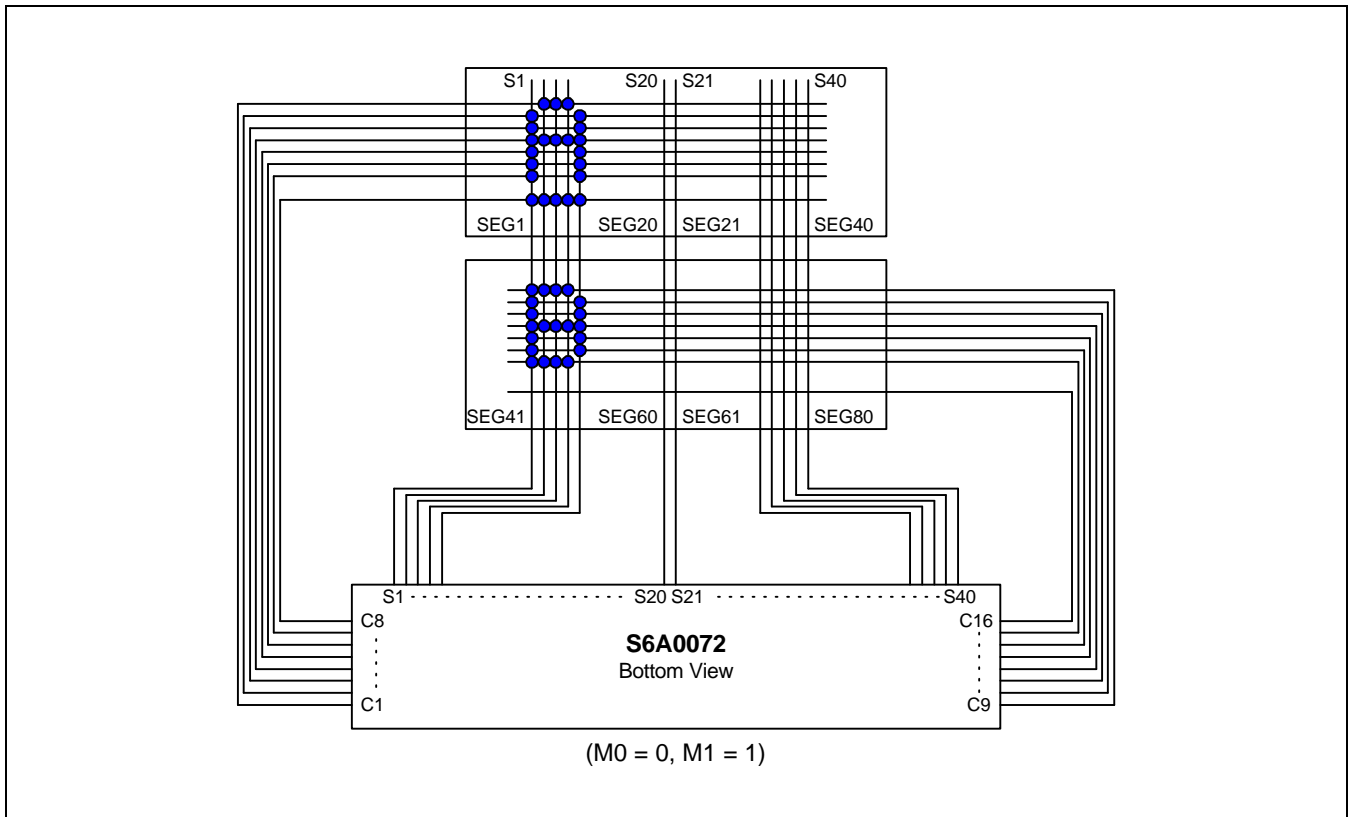

COM/SEG OUTPUT ROTATION MODE B

DDRAM Address Mode 0 (A = 0)

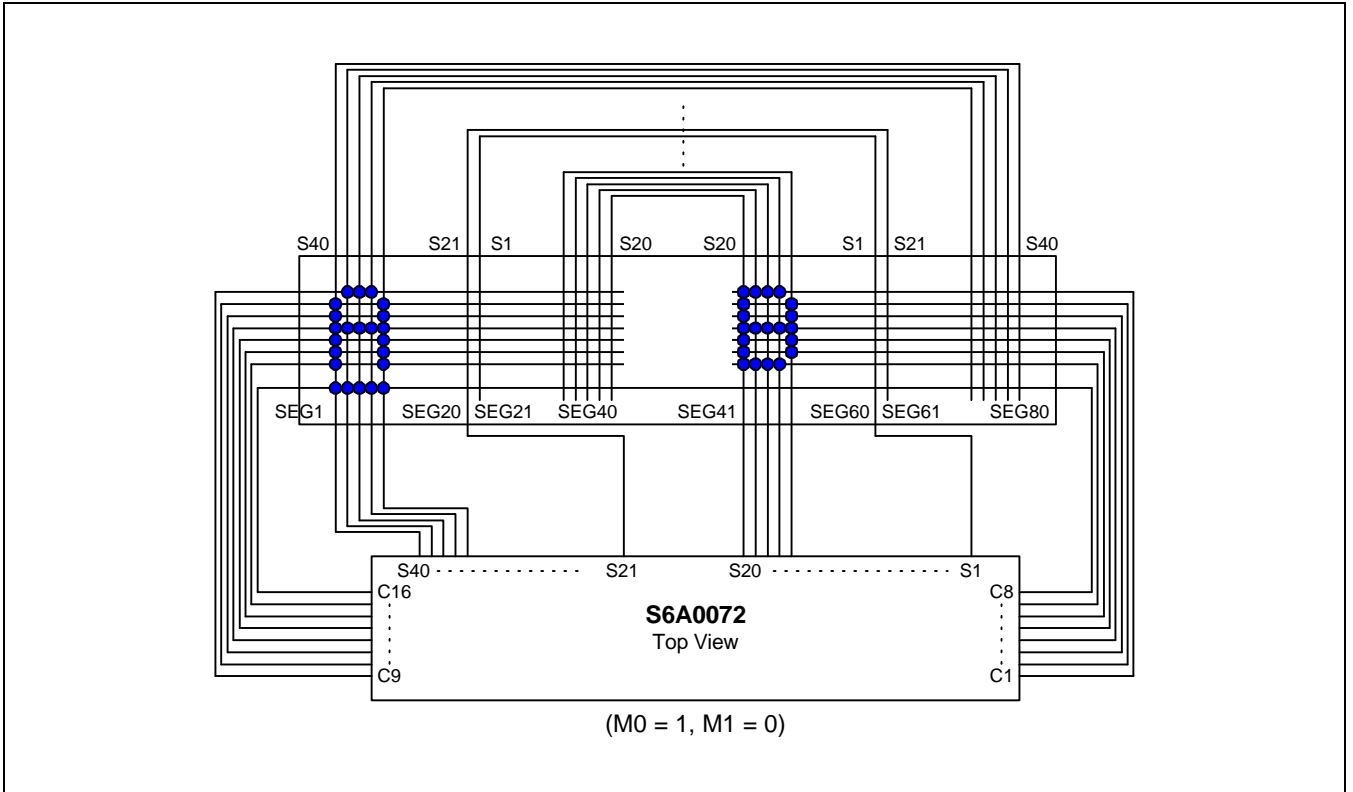

DDRAM Address Mode 1 (A = 1)

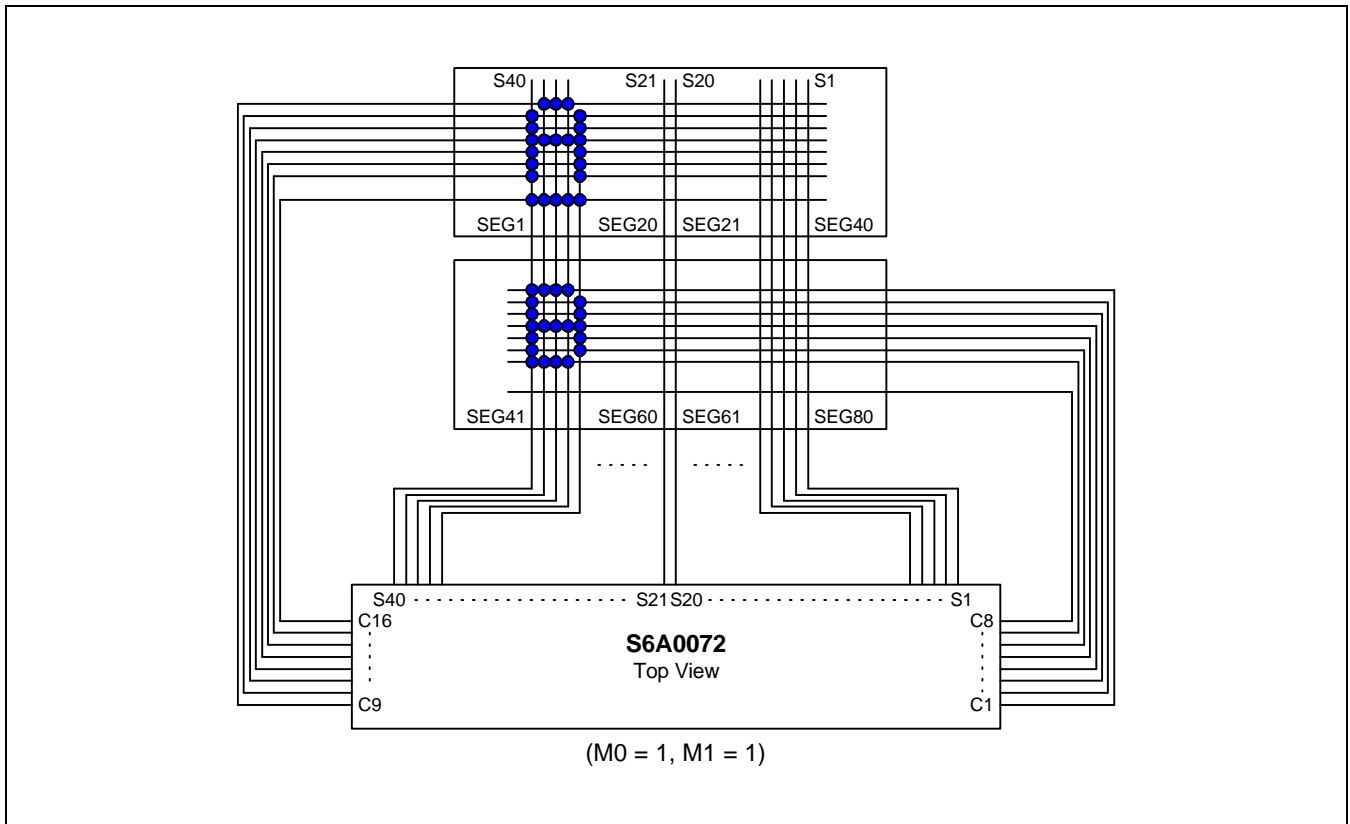

POWER SUPPLY FOR DRIVING LCD PANEL

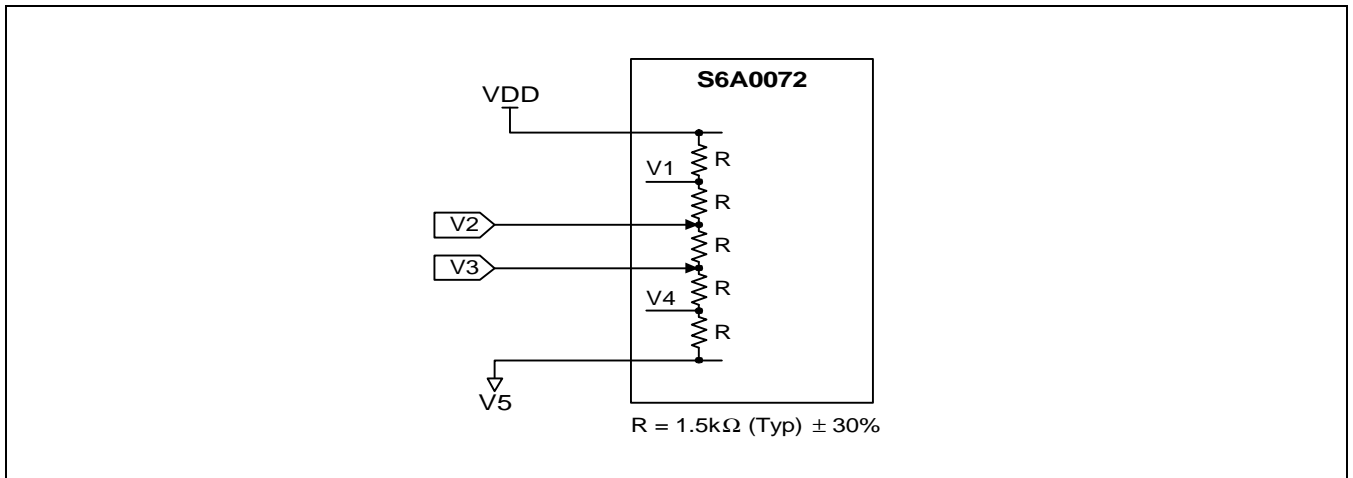

INITIALIZING

INITIALIZE BY INTERNAL POWER-ON-RESET CIRCUIT

When the power is turned on, S6A0072 is initialized automatically by power on reset circuit. During the initialization, the following instructions are executed, and BF (Busy Flag) is kept "High" (busy state) up to the end of initialization.

INITIALIZE FLOW

Display Clear

Write "20H" to all DDRAM

Set Functions

DL = 1: 8-bit bus mode

A = 0: DDRAM addressing mode 0

M0 = 0: COM/SEG output rotation mode A

M1 = 0: 1 line 16 character display mode

Control Display ON/OFF instruction

D = 0: Display OFF

C = 0: Cursor OFF

B = 0: Blink OFF

Set Entry Mode

I/D = 1: Increment by 1

S = 0: No entire display shift

INITIALIZE BY EXTERNAL HARDWARE RESET

If the "Low" signal is forced to reset terminal over a period of 1.2 ms then system will be initialized. And BF (Busy Flag) is kept "High" (busy state) for 629 us after releasing the initializing sequence.

INITIALIZING BY INSTRUCTION

8-bit Interface Mode

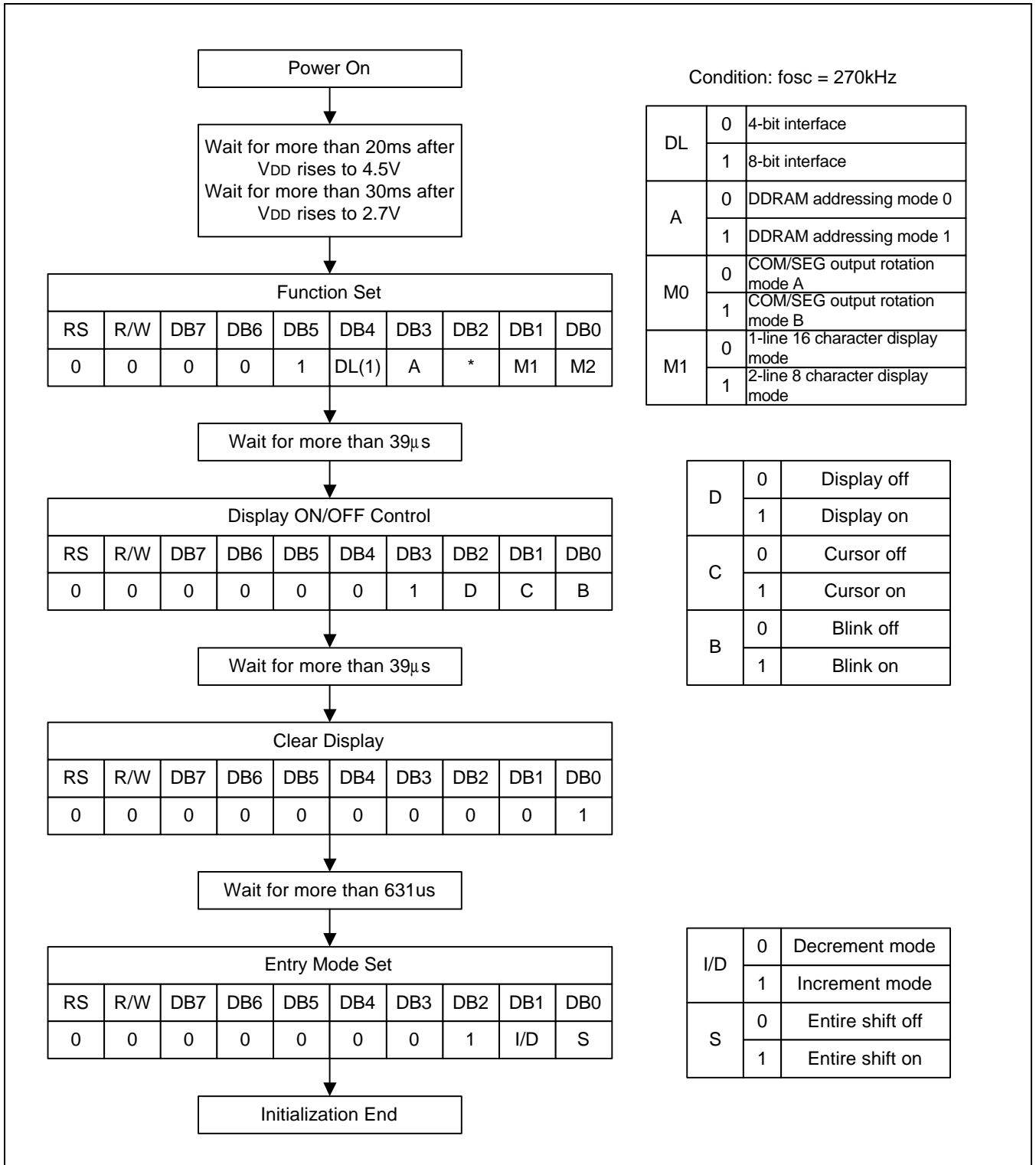

4-bit Interface Mode

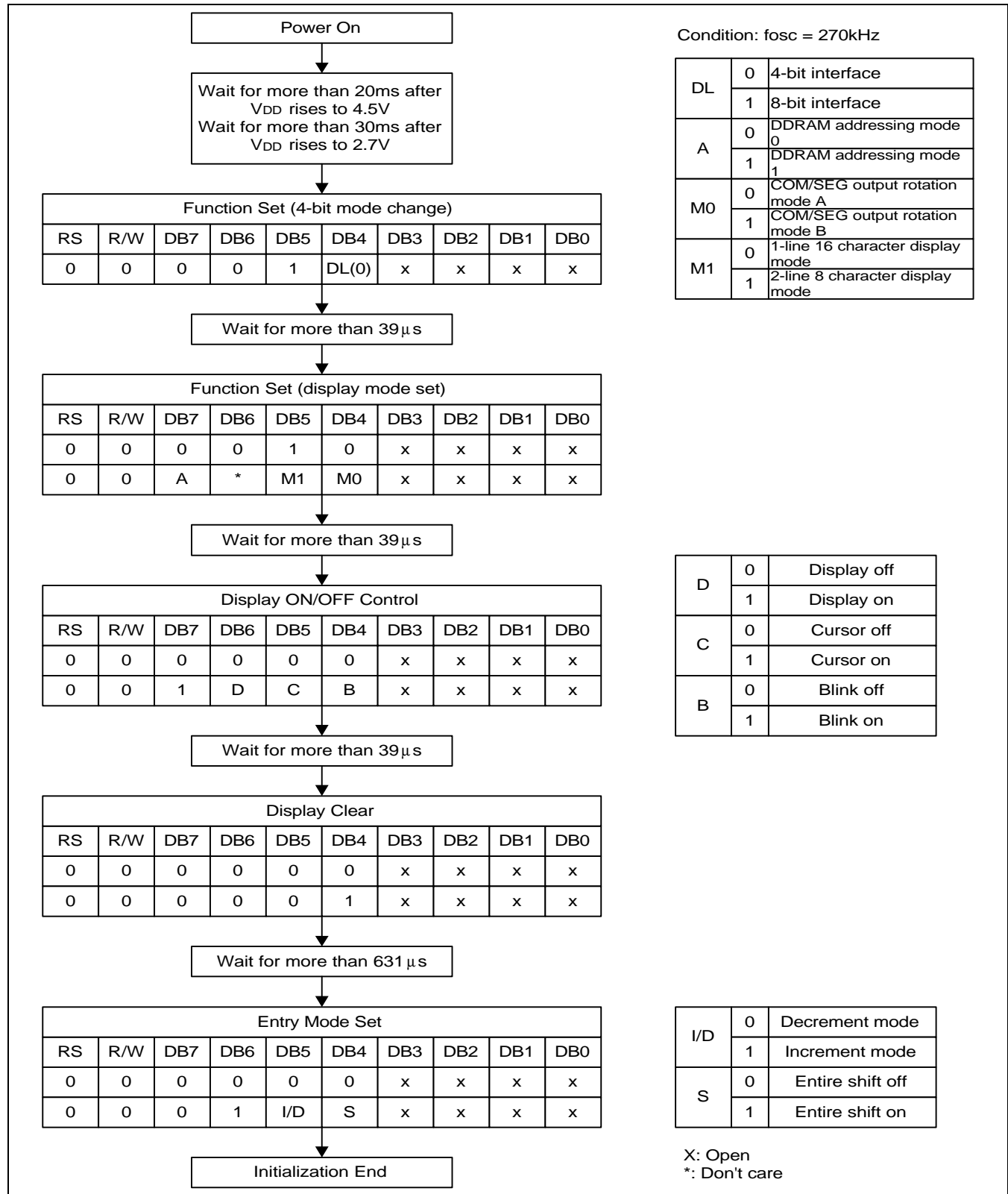

FRAME FREQUENCY

1/16 Duty Cycle

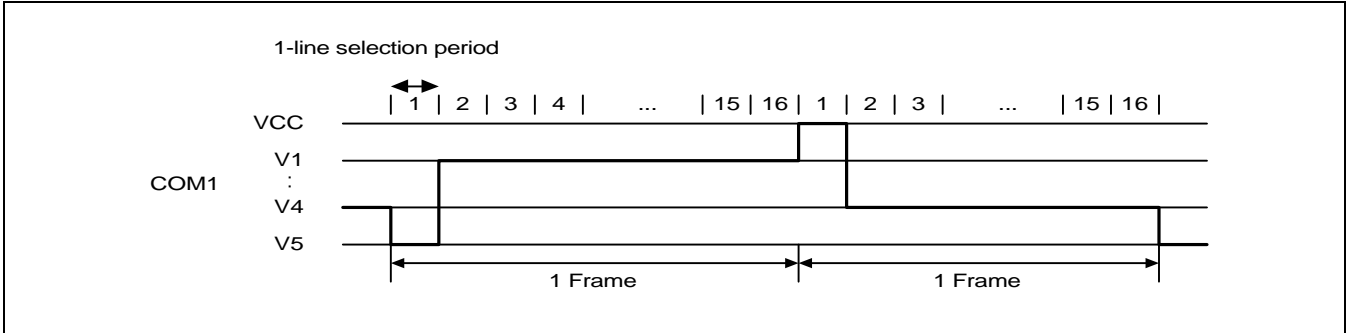

1-line selection period = 160 clocks

One Frame = 40 x 16 x 3.7μs x 4 = 9.472ms (1 CLOCK = 3.7μs at fosc = 270KHz)

Frame frequency = 1/9.472ms = 105.6Hz

MAXIMUM ABSOLUTE LIMIT**MAXIMUM ABSOLUTE POWER RATINGS**

Characteristic	Symbol	Value	Unit
Power supply voltage (1)	V_{DD}	-0.3 to +7.0	V
Power supply voltage (2)	V_{LCD}	-0.3 to +13	V
Input voltage	V_{IN}	-0.3 to $V_{DD}+0.3$	V

Voltage greater than above may damage to the circuit ($V_{DD} \geq V2 \geq V3 \geq V5$, $V_{LCD} = V_{DD}-V5$)

TEMPERATURE CHARACTERISTICS

Characteristic	Symbol	Value	Unit
Operating temperature	T_{OPR}	-30 to +85	°C
Storage temperature	T_{STG}	-55 to +125	°C

ELECTRICAL CHARACTERISTICS

DC CHARACTERISTICS

TABLE 5. DC CHARACTERISTICS ($V_{DD} = 4.5$ to $5.5V$, $T_a = -30$ to $+85^{\circ}C$)

Characteristic	Symbol	Condition	Min	Typ	Max	Unit
Operating voltage	V_{DD}	-	4.5	-	5.5	V
Supply current	I_{DD}	Internal oscillation ($V_{DD} = 5.0V$, $f_{osc} = 270kHz$)	-	1.5	1.8	mA
Input voltage (1) (except EXTCLK)	V_{IH1}	-	$0.7V_{DD}$	-	V_{DD}	V
	V_{IL1}	-	-0.3	-	0.8	
Input voltage (2) (EXTCLK)	V_{IH2}	-	$V_{DD}-1.0$	-	V_{DD}	V
	V_{IL2}	-	-0.2	-	1.0	
Input voltage (3) (E pin)	V_{IH3}	-	$0.8V_{DD}$	-	V_{DD}	V
	V_{IL3}	-	-	-	$0.2V_{DD}$	
Output voltage (1) (DB0 - DB7)	V_{OH1}	$I_{OH} = -0.205(mA)$	2.4	-	-	V
	V_{OL1}	$I_{OL} = 1.6(mA)$	-	-	0.4	
Voltage drop	V_{dCOM}	$I_O = \pm 0.1(mA)$	-	-	1	V
	V_{dSEG}		-	-	1	
Input leakage current	I_{IL}	$V_{IN} = 0V - V_{DD}$	-1	-	1	μA
Low input current	I_{IN}	$V_{IN} = 0V$, $V_{DD} = 5V$ (pull up)	-50	-125	-250	
LCD driving voltage	V2	$V_{DD} = 5V$, $V5 = 0V$ SEG output port	2.7	3.0	3.3	V
	V3		1.7	2.0	2.3	
Divide resistor	R_B	$V_{DD} - V5 = 5V$ $R_B = (V_{DD}-V5)/I_B$ $I_B =$ Divide resistor current	3.7	7.5	11.5	$k\Omega$
Internal clock (internal Rf)	f_{IC}	$V_{DD} = 5V$	190	270	350	kHz
LCD driving voltage	V_{LCD}	$V_{DD} - V5$	3.0	-	11.0	V

$(V_{DD} = 2.7 \text{ to } 4.5\text{V}, T_a = -30 \text{ to } +85^\circ\text{C})$

Characteristic	Symbol	Condition	Min	Typ	Max	Unit
Operating voltage	V_{DD}	-	2.7	-	4.5	V
Supply current	I_{DD}	Internal oscillation ($V_{DD} = 3.0\text{V}$, $f_{osc} = 270\text{kHz}$)	-	0.5	1.2	mA
Input voltage (1) (except EXTCLK)	V_{IH1}	-	$0.7V_{DD}$	-	V_{DD}	V
	V_{IL1}	-	-0.3	-	0.4	
Input voltage (2) (EXTCLK)	V_{IH2}	-	$V_{DD}-1.0$	-	V_{DD}	V
	V_{IL2}	-	-0.2	-	$0.2 V_{DD}$	
Input voltage (3) (E pin)	V_{IH3}	-	$0.8V_{DD}$	-	V_{DD}	V
	V_{IL3}	-	-	-	0.4	
Output voltage (1) (DB0 - DB7)	V_{OH1}	$I_{OH} = -0.1(\text{mA})$	$0.75 V_{DD}$	-	-	V
	V_{OL1}	$I_{OL} = 0.1(\text{mA})$	-	-	$0.2 V_{DD}$	
Voltage drop	V_{dCOM}	$I_O = \pm 0.1(\text{mA})$	-	-	1	V
	V_{dSEG}	$V_{LCD} = 5\text{V}$	-	-	1	
Input leakage current	I_{IL}	$V_{IN} = 0\text{V} - V_{DD}$	-1	-	1	μA
Low input current	I_{IN}	$V_{IN} = 0\text{V}$, $V_{DD} = 3\text{V}$ (pull up)	-10	-50	-120	
LCD driving voltage	V2	$V_{DD} = 3\text{V}$, V5 = -2V SEG output port	0.7	1.0	1.3	V
	V3		-0.3	0	0.3	
Divide resistor	R_B	$V_{DD} - V5 = 5\text{V}$ $R_B = (V_{DD}-V5)/I_B$ $I_B = \text{Divide resistor current}$	3.7	7.5	11.5	$\text{k}\Omega$
Internal clock (internal Rf)	f_{IC}	$V_{DD} = 5\text{V}$	190	270	350	kHz
LCD driving voltage	V_{LCD}	$V_{DD} - V5$	3.0	-	11.0	V

AC CHARACTERISTICS

Table 6. AC Characteristics (VDD = 4.5 TO 5.5V, TA = -30 TO +85°C)

Mode	Item	Symbol	Min	Typ	Max	Unit
Write mode (refer to Figure 3)	E cycle time	tc,	500	-	-	ns
	E rise/fall time	tr, tf	-	-	20	
	E pulse width (high, low)	tw	230	-	-	
	R/W and RS setup time	tsu1	40	-	-	
	R/W and RS hold time	th1	10	-	-	
	Data setup time	tsu2	80	-	-	
	Data hold time	th2	10	-	-	
Read mode (refer to Figure 4)	E cycle time	tc	500	-	-	ns
	E rise/fall time	tr, tf	-	-	20	
	E pulse width (high, low)	tw	230	-	-	
	R/W and RS setup time	tsu	40	-	-	
	R/W and RS hold time	th	10	-	-	
	Data output delay time	t _D	-	-	120	
	Data hold time	t _{DH}	20	-	-	

Table 6. AC Characteristics (VDD = 2.7 TO 4.5V, TA = -30 TO +85°C)

Mode	Item	Symbol	Min	Typ	Max	Unit
Write mode (refer to Figure 3)	E cycle time	tc,	1000	-	-	ns
	E rise/fall time	tr, tf	-	-	25	
	E pulse width (high, low)	tw	450	-	-	
	R/W and RS setup time	tsu1	60	-	-	
	R/W and RS hold time	th1	20	-	-	
	Data setup time	tsu2	195	-	-	
	Data hold time	th2	10	-	-	
Read mode (refer to Figure 4)	E cycle time	tc	1000	-	-	ns
	E rise/fall time	tr, tf	-	-	25	
	E Pulse width (high, low)	tw	450	-	-	
	R/W and RS setup time	tsu	60	-	-	
	R/W and RS hold time	th	20	-	-	
	Data output delay time	t _D	-	-	360	
	Data hold time	t _{DH}	5	-	-	

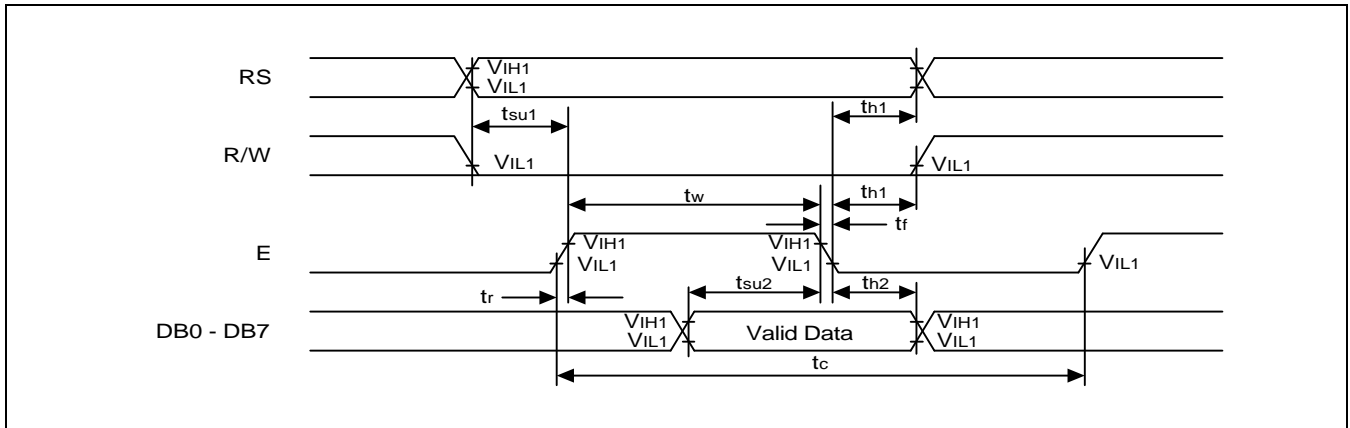

Figure 3. Write Mode Timing Diagram

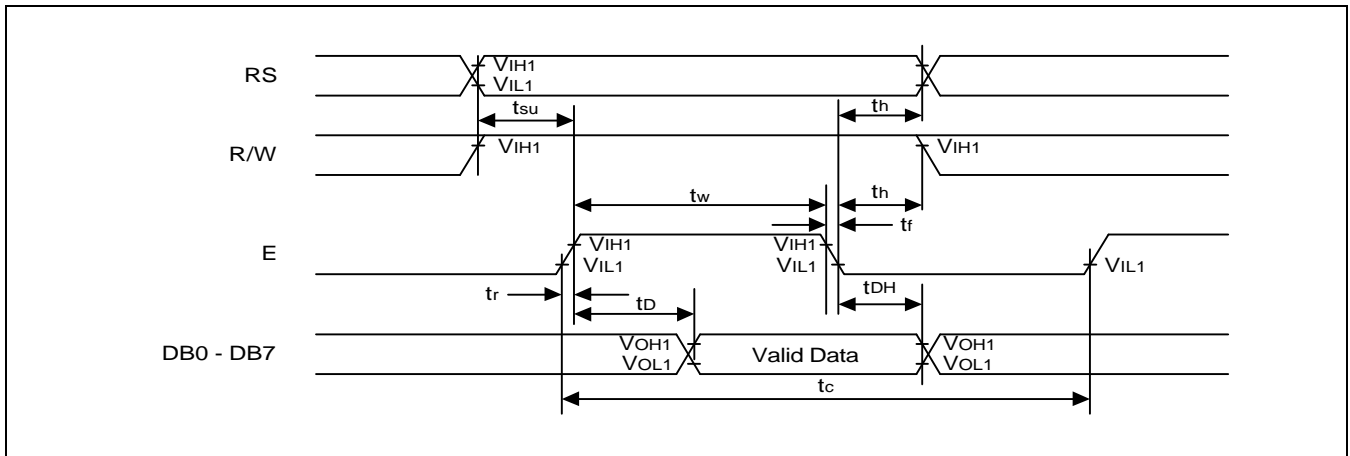

Figure 4. Read Mode Timing Diagram