

**Features**

- **Automatic power-down when deselected**
- **CMOS for optimum speed/power**
- **High speed**  
—  $t_{AA} = 15 \text{ ns}$
- **Low active power**  
— 633 mW
- **Low standby power**  
— 110 mW
- **TTL-compatible inputs and outputs**
- $V_{IH}$  of 2.2V
- **Capable of withstanding greater than 2001V electrostatic discharge**

**Functional Description**

The CY7C168A is a high-performance CMOS static RAM organized as 4096 by 4 bits. Easy memory expansion is provided by an active LOW Chip Enable ( $\overline{CE}$ ) and three-state drivers. The CY7C168A has an automatic power-down feature, reducing the power consumption by 77% when deselected.

Writing to the device is accomplished when the Chip Select ( $\overline{CE}$ ) and Write Enable ( $\overline{WE}$ ) inputs are both LOW. Data on the four data input/output pins ( $I/O_0$  through  $I/O_3$ ) is written into the memory location specified on the address pins ( $A_0$  through  $A_{11}$ ).

Reading the device is accomplished by taking the Chip Enable ( $\overline{CE}$ ) LOW, while Write Enable ( $\overline{WE}$ ) remains HIGH. Under these conditions, the contents of the location specified on the address pins will appear on the four data input/output pins ( $I/O_0$  through  $I/O_3$ ).

The input/output pins remain in a high-impedance state when Chip Enable ( $\overline{CE}$ ) is HIGH or Write Enable ( $\overline{WE}$ ) is LOW.

A die coat is used to insure alpha immunity.

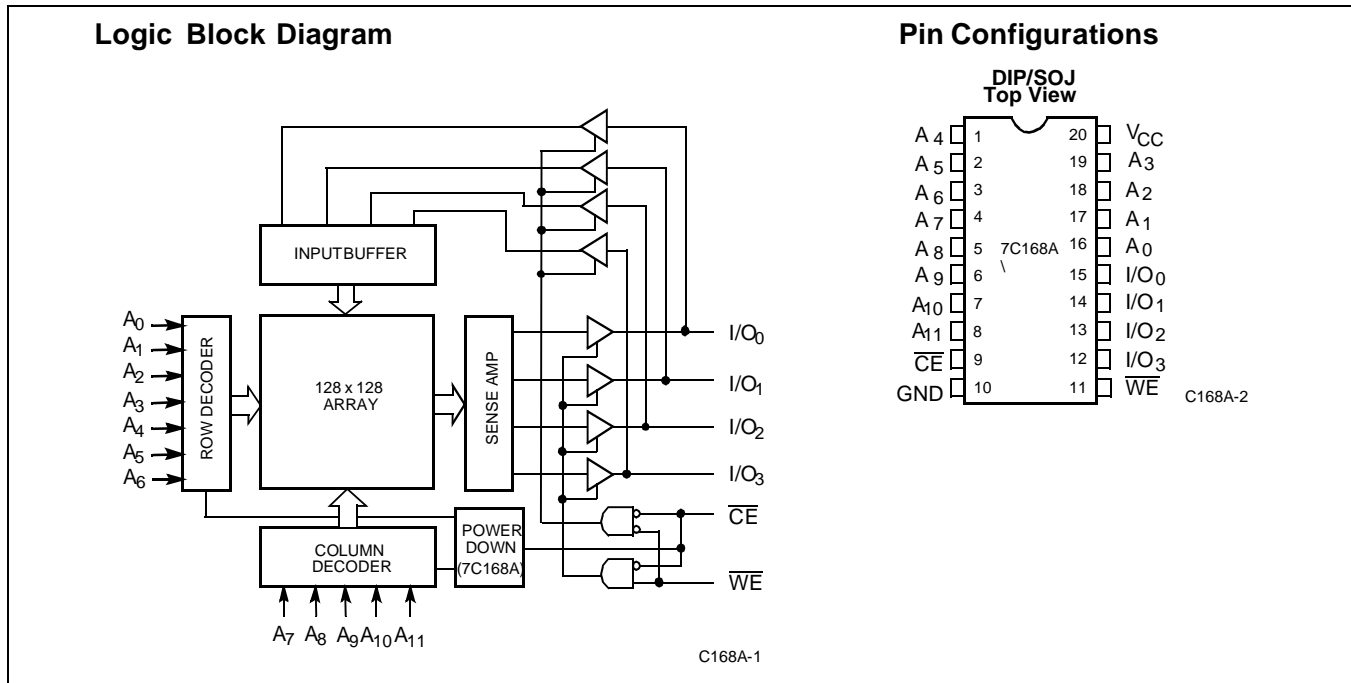
**Selection Guide**

		7C168A-15	7C168A-20	7C168A-25	7C168A-35	7C168A-45
Maximum Access Time (ns)		15	20	25	35	45
Maximum Operating Current (mA)	Commercial	115	90	90	90	90
	Military	-	100	100	100	100

**Maximum Ratings**

(Above which the useful life may be impaired. For user guidelines, not tested.)

Storage Temperature ..... -65°C to +150°C  
 Ambient Temperature with Power Applied ..... -55°C to +125°C  
 Supply Voltage to Ground Potential (Pin 20 to Pin 10) ..... -0.5V to +7.0V  
 DC Voltage Applied to Outputs in High Z State ..... -0.5V to +7.0V  
 DC Input Voltage ..... -3.0V to +7.0V

Output Current into Outputs (Low) ..... 20 mA  
 Static Discharge Voltage ..... >2001V (per MIL-STD-883, Method 3015)  
 Latch-Up Current ..... >200 mA

**Operating Range**

Range	Ambient Temperature	V <sub>CC</sub>
Commercial	0°C to +70°C	5V ± 10%
Military <sup>[1]</sup>	-55°C to +125°C	5V ± 10%

**Electrical Characteristics** Over the Operating Range<sup>[2]</sup>

Parameter	Description	Test Conditions	7C168A-15		7C168A-20		Unit
			Min.	Max.	Min.	Max.	
V <sub>OH</sub>	Output HIGH Voltage	V <sub>CC</sub> = Min., I <sub>OH</sub> = -4.0 mA	2.4		2.4		V
V <sub>OL</sub>	Output LOW Voltage	V <sub>CC</sub> = Min., I <sub>OL</sub> = 8.0 mA		0.4		0.4	V
V <sub>IH</sub>	Input HIGH Voltage		2.2	V <sub>CC</sub>	2.2	V <sub>CC</sub>	V
V <sub>IL</sub>	Input LOW Voltage <sup>[3]</sup>		-0.5	0.8	-0.5	0.8	V
I <sub>IX</sub>	Input Load Current	GND ≤ V <sub>I</sub> ≤ V <sub>CC</sub>	-10	+10	-10	+10	μA
I <sub>OZ</sub>	Output Leakage Current	GND ≤ V <sub>O</sub> ≤ V <sub>CC</sub> , Output Disabled	-10	+10	-10	+10	μA
I <sub>OS</sub>	Output Short Circuit Current <sup>[4]</sup>	V <sub>CC</sub> = Max., V <sub>OUT</sub> = GND		-350		-350	mA
I <sub>CC</sub>	V <sub>CC</sub> Operating Supply Current	V <sub>CC</sub> = Max., I <sub>OUT</sub> = 0 mA	Com'l	115		90	mA
			Mil	-		100	
I <sub>SB1</sub>	Automatic $\overline{CE}$ Power-Down Current	Max. V <sub>CC</sub> , $\overline{CE} \geq V_{IH}$	Com'l	40		40	mA
			Mil	-		40	
I <sub>SB2</sub>	Automatic $\overline{CE}$ Power-Down Current	Max. V <sub>CC</sub> , $\overline{CE} \geq V_{CC} - 0.3V$	Com'l	20		20	mA
			Mil	-		20	

**Notes:**

1. T<sub>A</sub> is the "instant on" case temperature.
2. See the last page of this specification for Group A subgroup testing information.
3. V<sub>IL</sub> min. = -3.0V for pulse durations less than 30 ns.
4. Not more than 1 output should be shorted at one time. Duration of the short circuit should not exceed 30 seconds.

**Electrical Characteristics** Over the Operating Range<sup>[2]</sup> (continued)

Parameter	Description	Test Conditions	7C168A-25		7C168A-35		7C168A-45		Unit
			Min.	Max.	Min.	Max.	Min.	Max.	
V <sub>OH</sub>	Output HIGH Voltage	V <sub>CC</sub> = Min., I <sub>OH</sub> = -4.0 mA	2.4		2.4		2.4		V
V <sub>OL</sub>	Output LOW Voltage	V <sub>CC</sub> = Min., I <sub>OL</sub> = 8.0 mA		0.4		0.4		0.4	V
V <sub>IH</sub>	Input HIGH Voltage		2.2	V <sub>CC</sub>	2.2	V <sub>CC</sub>	2.2	V <sub>CC</sub>	V
V <sub>IL</sub>	Input LOW Voltage <sup>[3]</sup>		-0.5	0.8	-0.5	0.8	-0.5	0.8	V
I <sub>IX</sub>	Input Load Current	GND ≤ V <sub>I</sub> ≤ V <sub>CC</sub>	-10	+10	-10	10	-10	10	μA
I <sub>OZ</sub>	Output Leakage Current	GND ≤ V <sub>O</sub> ≤ V <sub>CC</sub> Output Disabled	-10	+10	-50	50	-50	50	μA
I <sub>OS</sub>	Output Short Circuit Current <sup>[4]</sup>	V <sub>CC</sub> = Max., V <sub>OUT</sub> = GND		-350		-350		-350	mA
I <sub>CC</sub>	V <sub>CC</sub> Operating Supply Current	V <sub>CC</sub> = Max., I <sub>OUT</sub> = 0 mA	Com'l	90		90		90	mA
			Mil		100		100		
I <sub>SB1</sub>	Automatic $\overline{CE}$ Power-Down Current	Max. V <sub>CC</sub> , $\overline{CE} \geq V_{IH}$	Com'l	20		20		20	mA
			Mil		20		20		
I <sub>SB2</sub>	Automatic $\overline{CE}$ Power-Down Current	Max. V <sub>CC</sub> , $\overline{CE} \geq V_{CC} - 0.3 V$	Com'l	20		20		20	mA
			Mil		20		20		

**Capacitance<sup>[5]</sup>**

Parameter	Description	Test Conditions	Max.	Unit
C <sub>IN</sub>	Input Capacitance	T <sub>A</sub> = 25°C, f = 1 MHz, V <sub>CC</sub> = 5.0V	10	pF
C <sub>OUT</sub>	Output Capacitance		10	pF

**Note:**

5. Tested initially and after any design or process changes that may affect these parameters.

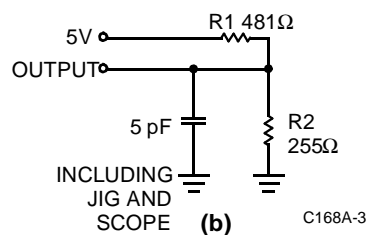
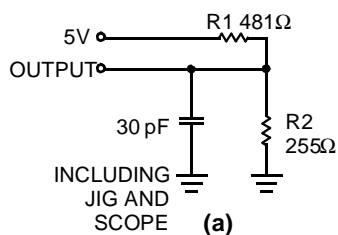
**AC Test Loads and Waveforms**

C168A-3

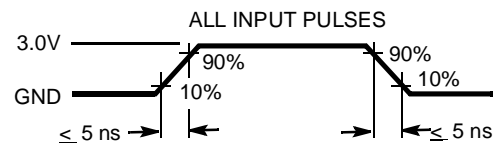

C168A-4

Equivalent to: THÉVENIN EQUIVALENT

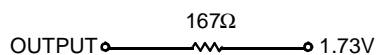

**Switching Characteristics** Over the Operating Range<sup>[2,6]</sup>

Parameter	Description	7C168A-15		7C168A-20		7C168A-25		7C168A-35		7C168A-45		Unit
		Min.	Max.	Min.	Max.	Min.	Max.	Min.	Max.	Min.	Max.	
<b>READ CYCLE</b>												
$t_{RC}$	Read Cycle Time	15		20		25		35		45		ns
$t_{AA}$	Address to Data Valid		15		20		25		35		45	ns
$t_{OHA}$	Output Hold from Address Change	5		5		5		5		5		ns
$t_{ACE}$	Power Supply Current		15		20		25		35		45	ns
$t_{LZCE}$	$\overline{CE}$ LOW to Low Z <sup>[7]</sup>	5		5		5		5		5		ns
$t_{HZCE}$	$\overline{CE}$ HIGH to High Z <sup>[7, 8]</sup>		8		8		10		15		15	ns
$t_{PU}$	$\overline{CE}$ LOW to Power Up	0		0		0		0		0		ns
$t_{PD}$	$\overline{CE}$ HIGH to Power-Down		15		20		20		20		25	ns
$t_{RCS}$	Read Command Set-Up	0		0		0		0		0		ns
$t_{RCH}$	Read Command Hold	0		0		0		0		0		ns
<b>WRITE CYCLE<sup>[9]</sup></b>												
$t_{WC}$	Write Cycle Time	15		20		20		25		40		ns
$t_{SCE}$	$\overline{CE}$ LOW to Write End	12		15		20		25		30		ns
$t_{AW}$	Address Set-Up to Write End	12		15		20		25		30		ns
$t_{HA}$	Address Hold from Write End	0		0		0		0		0		ns
$t_{SA}$	Address Set-Up to Write Start	0		0		0		0		0		ns
$t_{PWE}$	$\overline{WE}$ Pulse Width	12		15		15		20		20		ns
$t_{SD}$	Data Set-Up to Write End	10		10		10		15		15		ns
$t_{HD}$	Data Hold from Write End	0		0		0		0		0		ns
$t_{LZWE}$	$\overline{WE}$ HIGH to Low Z <sup>[7]</sup>	7		7		7		5		5		ns
$t_{HZWE}$	$\overline{WE}$ LOW to High Z <sup>[7, 8]</sup>	5		5		5		5		10		ns

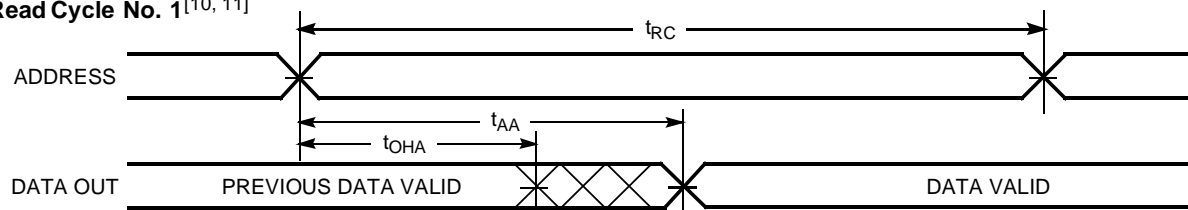
**Switching Waveforms**
**Read Cycle No. 1<sup>[10, 11]</sup>**

C168A-5

**Notes:**

6. Test conditions assume signal transition times of 5 ns or less, timing reference levels of 1.5V, input pulse levels of 0 to 3.0V, and output loading of the specified  $I_{OL}/I_{OH}$  and 30-pF load capacitance.
7. At any given temperature and voltage condition,  $t_{HZ}$  is less than  $t_{LZ}$  for all devices. Transition is measured  $\pm 500$  mV from steady state voltage with specified loading in part (b) of AC Test Loads and Waveforms.
8.  $t_{HZCE}$  and  $t_{HZWE}$  are tested with  $C_L = 5$  pF as in part (a) of Test Loads and Waveforms. Transition is measured  $\pm 500$  mV from steady state voltage.
9. The internal write time of the memory is defined by the overlap of  $\overline{CE}$  LOW and  $\overline{WE}$  LOW. Both signal must be LOW to initiate a write and either signal can terminate a write by going high. The data input set-up and hold timing should be referenced to the rising edge of the signal that terminates the write.
10.  $\overline{WE}$  is HIGH for read cycle.
11. Device is continuously selected,  $\overline{CE} = V_{IL}$ .

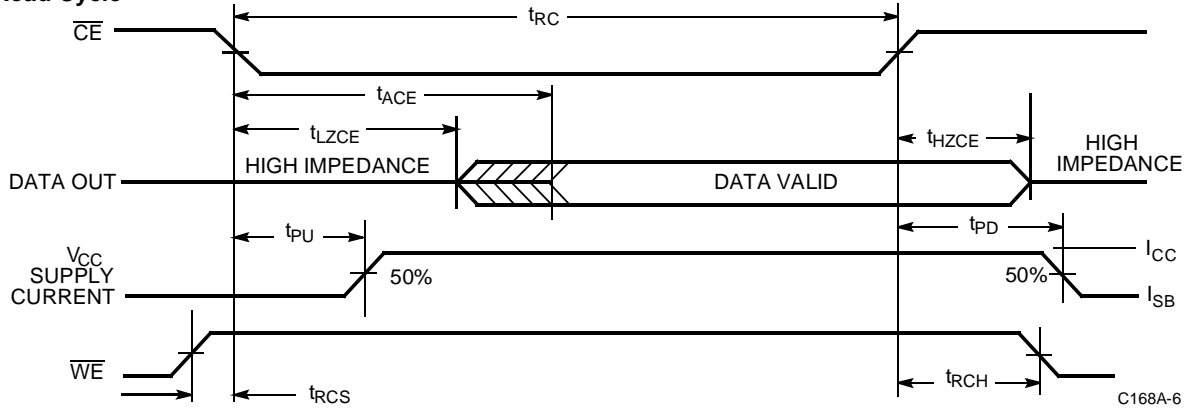
**Switching Waveforms (continued)**
**Read Cycle<sup>[10, 12]</sup>**

C168A-6

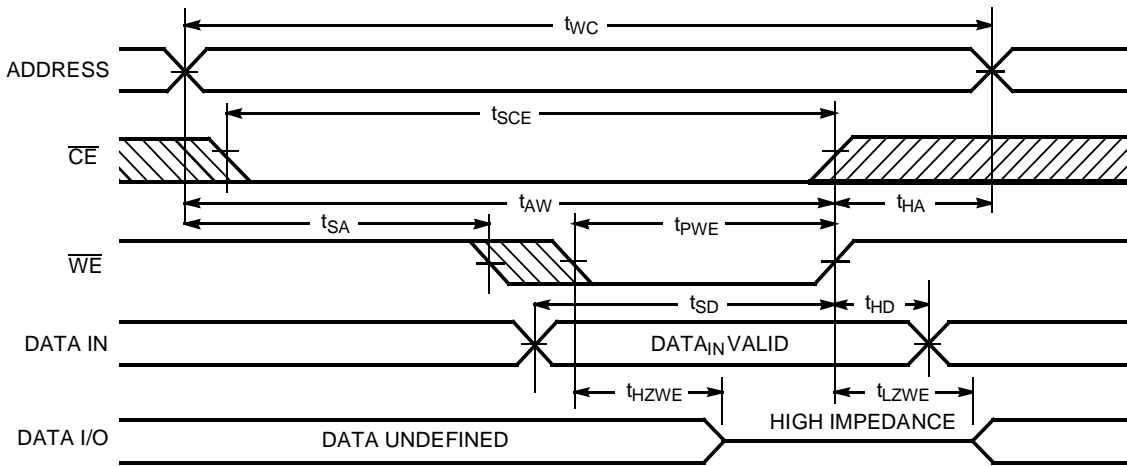
**Write Cycle No. 1 ( $\overline{WE}$  Controlled)<sup>[9]</sup>**

C168A-7

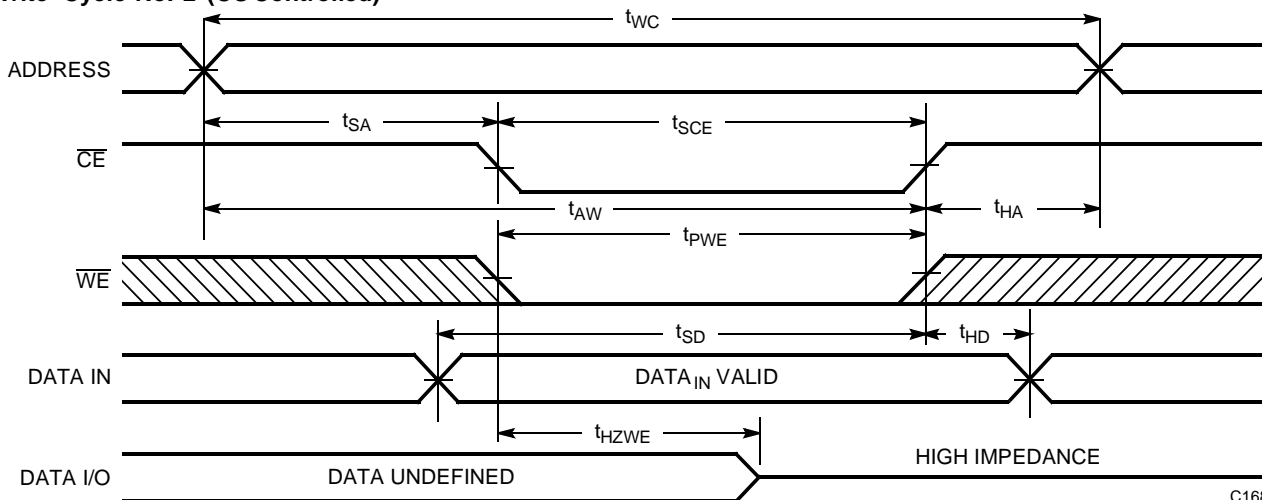
**Write Cycle No. 2 ( $\overline{CS}$  Controlled)<sup>[9, 13]</sup>**

C168A-8

**Notes:**

12. Address valid prior to or coincident with CE transition LOW.
13. If CE goes HIGH simultaneously with WE HIGH, the output remains in a high-impedance state.

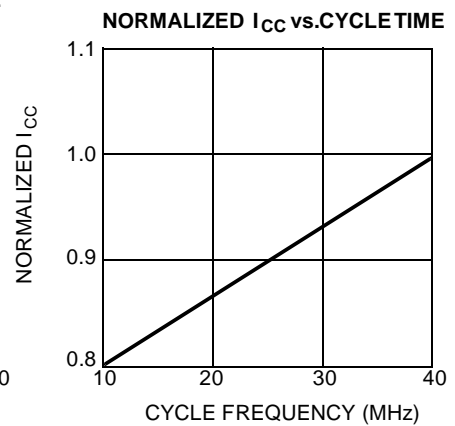
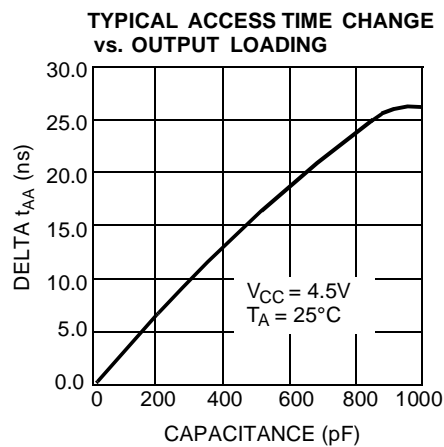
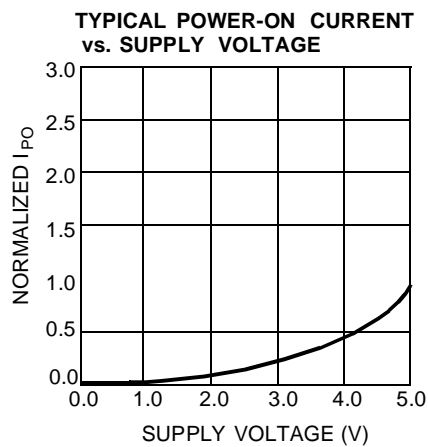
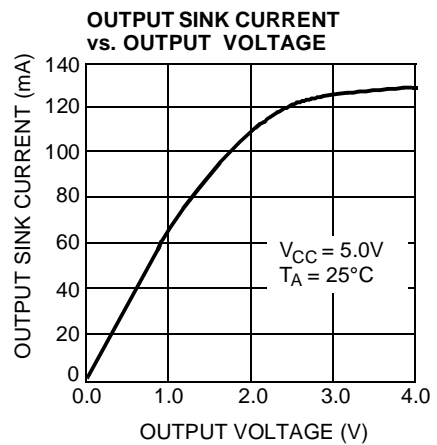
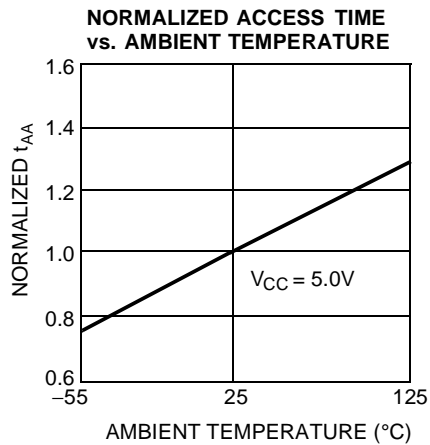
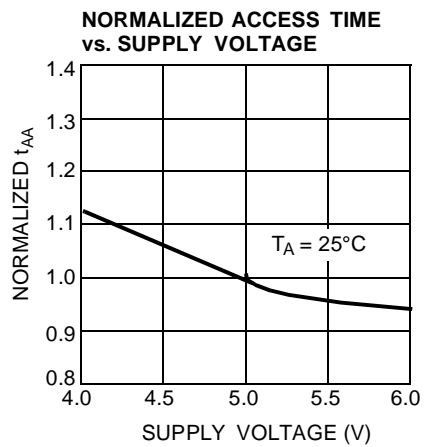
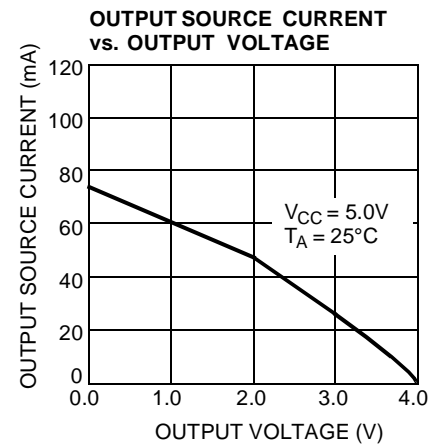
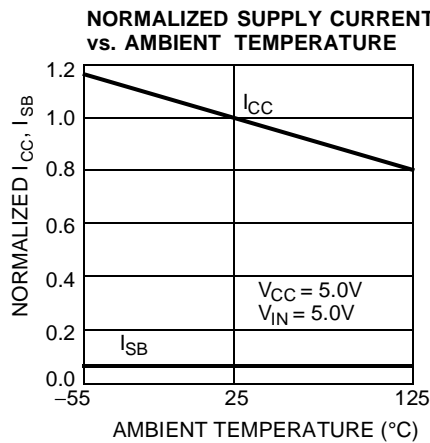
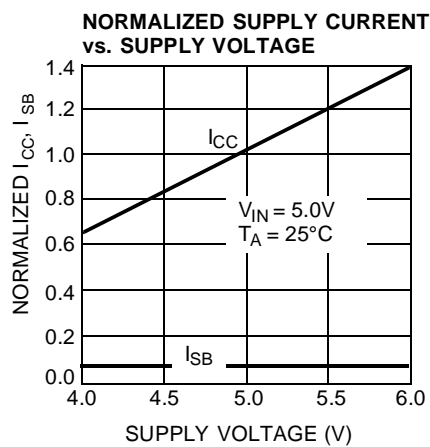
**Typical DC and AC Characteristics**

**Ordering Information**

Speed (ns)	I <sub>CC</sub> (mA)	Ordering Code	Package Name	Package Type	Operating Range
15	115	CY7C168A-15PC	P5	20-Lead (300-Mil) Molded DIP	Commercial
		CY7C168A-15VC	V5	20-Lead Molded SOJ	
20	90	CY7C168A-20PC	P5	20-Lead (300-Mil) Molded DIP	Commercial
		CY7C168A-20VC	V5	20-Lead Molded SOJ	
		CY7C168A-20DMB	D6	20-Lead (300-Mil) CerDIP	Military
25	70	CY7C168A-25PC	P5	20-Lead (300-Mil) Molded DIP	Commercial
		CY7C168A-25VC	V5	20-Lead Molded SOJ	
	80	CY7C168A-25DMB	D6	20-Lead (300-Mil) CerDIP	Military
35	70	CY7C168A-35PC	P5	20-Lead (300-Mil) Molded DIP	Commercial
		CY7C168A-35VC	V5	20-Lead Molded SOJ	
		CY7C168A-35DMB	D6	20-Lead (300-Mil) CerDIP	Military
45	70	CY7C168A-45PC	P5	20-Lead (300-Mil) Molded DIP	Commercial
		CY7C168A-45VC	V5	20-Lead Molded SOJ	
		CY7C168A-45DMB	D6	20-Lead (300-Mil) CerDIP	Military

**MILITARY SPECIFICATIONS**  
**Group A Subgroup Testing**
**DC Characteristics**

Parameter	Subgroups
V <sub>OH</sub>	1, 2, 3
V <sub>OL</sub>	1, 2, 3
V <sub>IH</sub>	1, 2, 3
V <sub>IL Max.</sub>	1, 2, 3
I <sub>IX</sub>	1, 2, 3
I <sub>OZ</sub>	1, 2, 3
I <sub>CC</sub>	1, 2, 3
I <sub>SB1</sub>	1, 2, 3
I <sub>SB2</sub>	1, 2, 3

Document #: 38-00095-E

**Switching Characteristics**

Parameter	Subgroups
<b>READ CYCLE</b>	
t <sub>RC</sub>	7, 8, 9, 10, 11
t <sub>AA</sub>	7, 8, 9, 10, 11
t <sub>OHA</sub>	7, 8, 9, 10, 11
t <sub>ACE</sub>	7, 8, 9, 10, 11
t <sub>RCS</sub>	7, 8, 9, 10, 11
t <sub>RCH</sub>	7, 8, 9, 10, 11
<b>WRITE CYCLE</b>	
t <sub>WC</sub>	7, 8, 9, 10, 11
t <sub>SCE</sub>	7, 8, 9, 10, 11
t <sub>AW</sub>	7, 8, 9, 10, 11
t <sub>HA</sub>	7, 8, 9, 10, 11
t <sub>SA</sub>	7, 8, 9, 10, 11
t <sub>PWE</sub>	7, 8, 9, 10, 11
t <sub>SD</sub>	7, 8, 9, 10, 11
t <sub>HD</sub>	7, 8, 9, 10, 11

Package Diagrams

**20-Lead (300-Mil) CerDIP D6**  
MIL-STD-1835 D-8 Config. A

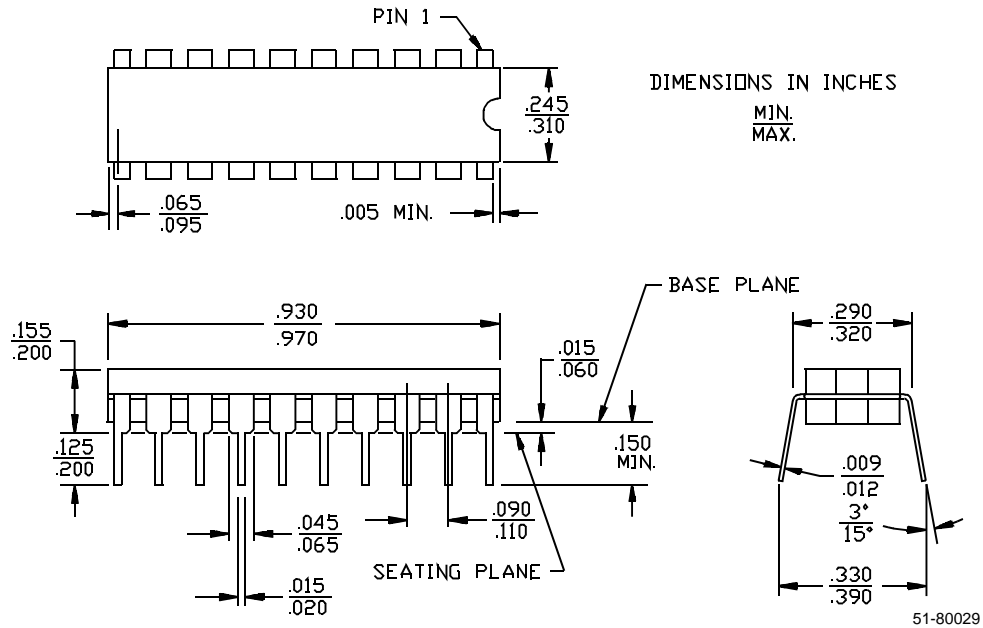

**20-Lead (300-Mil) Molded DIP P5**

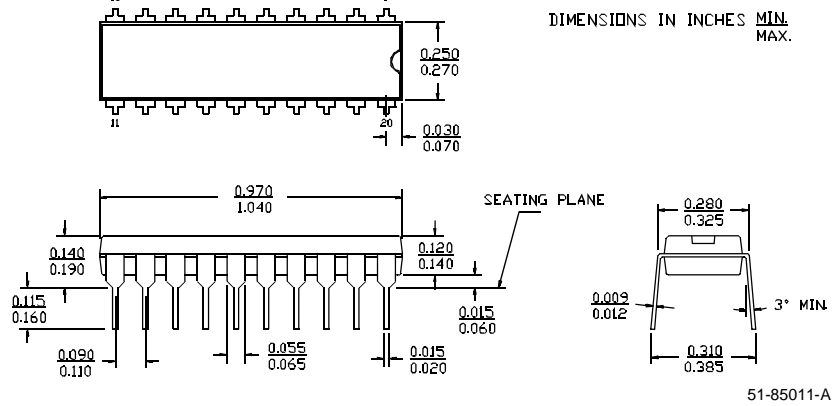



Package Diagrams (continued)

20-Lead (300-Mil) Molded SOJ V5

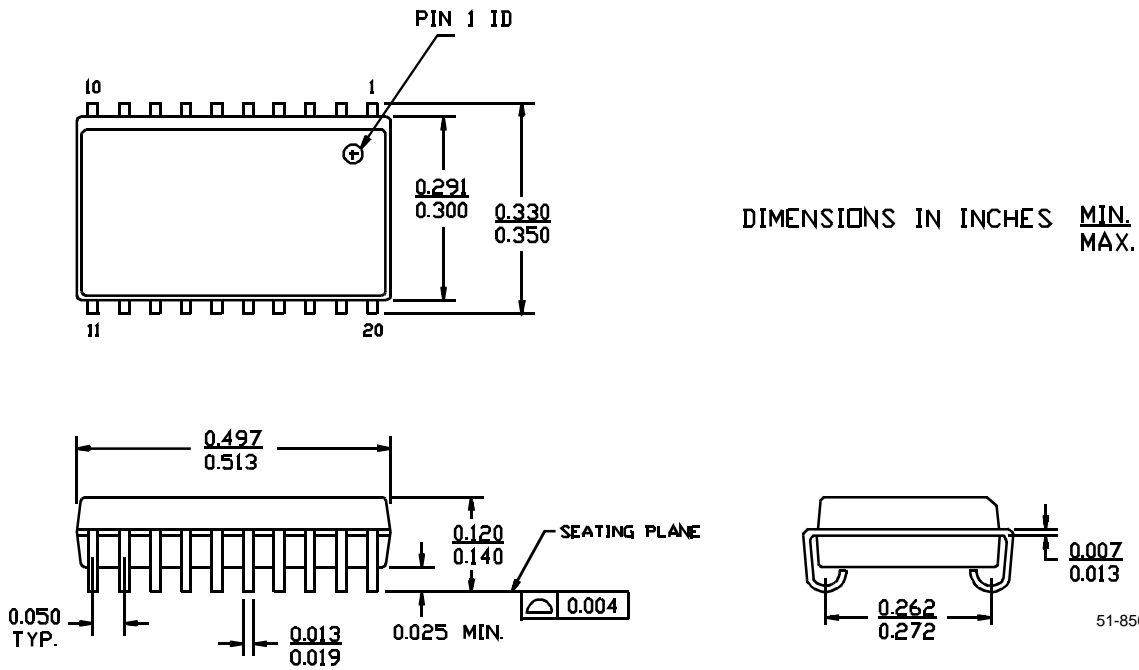

51-85029-A