

POWEREX

Powerex, Inc. Hillis Street, Youngwood, Pennsylvania 15697 (412) 925-7272
 Powerex Europe, S.A., 428 Ave. G. Durand, BP107, 72003 LeMans, France (43) 72.75.15

T620/T630

Phase Control SCR
 150-300 Amperes Avg
 100-1600 Volts

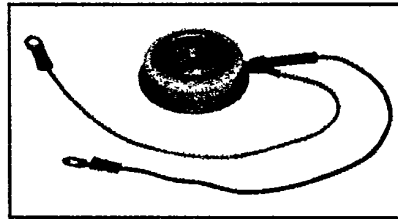
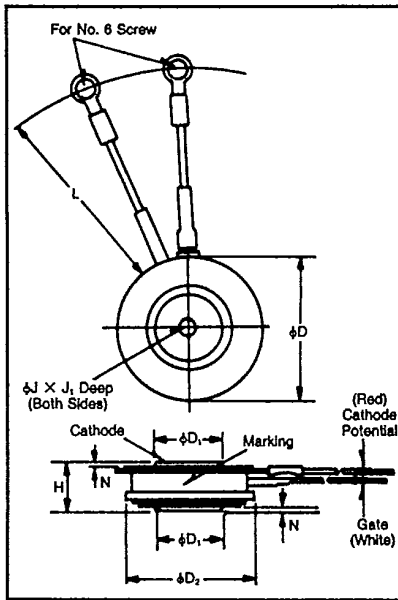

T620/T630
Phase Control SCR
 150-300 Amperes/100-1600 Volts

Description

Powerex Silicon Controlled Rectifiers (SCR) are designed for phase control applications. These are all-diffused, Press-Pak (Pow-R-Disc) devices employing the field-proven amplifying (di/namic) gate.

Features:

- Low On-State Voltage
- High di/dt
- High dv/dt
- Hermetic Packaging
- Excellent Surge and I^2t Ratings

Applications:

- Power Supplies
- Battery Chargers
- Motor Control
- Light Dimmers
- VAR Generators

Ordering Information

Example: Select the complete eight digit part number you desire from the table - i.e. T6200820 is a 800 Volt, 200 Ampere Phase Control SCR.

T62

Outline Drawing

Dimensions	Inches		Millimeters	
	Min.	Max.	Min.	Max.
ϕD	1.610	1.650	40.89	41.91
ϕD_1	.745	.755	18.92	19.18
ϕD_2	1.420	1.460	36.07	37.08
H	.500	.560	12.70	14.22
ϕJ	.135	.145	3.43	3.68
J_1	.072	.082	1.83	2.08
L	7.75	8.50	196.85	215.90
N	.030	—	.76	—

Creep Distance—.34 in. min. (8.64 mm)

Strike Distance—.26 in. min. (6.60 mm).

(In accordance with NEMA standards.)

Finish—Nickel Plate.

Approx. Weight—2.3 oz. (66 g).

1. Dimension "H" is clamped dimension.

Type	Voltage		Current	
	V_{ORM}	Code	I_r (avg)	Code
T630	100	01	150	15
	200	02	200	20
	300	03	300	30
	400	04		
	500	05		
	600	06		
T620	700	07		
	800	08		
	900	09		
	1000	10		
	1100	11		
	1200	12		
	1300	13		
	1400	14		
	1500	15		
	1600	16		



T-25-19

Powerex, Inc., Hills Street, Youngwood, Pennsylvania 15697 (412) 925-7272

Powerex Europe, S.A., 428 Ave. G. Durand, BP107, 72003 LeMans, France (43) 72.75.15

T620/T630

Phase Control SCR

150-300 Amperes Avg/100-1600 Volts

Absolute Maximum Ratings

	Symbol	T620 -- 15	T620 -- 20	T620 -- 30	Units
		T630 -- 15	T630 -- 20	T630 -- 30	
RMS On-State Current	$I_{T(RMS)}$	235	315	470	Amperes
Average On-State Current	$I_{T(av)}$	150	200	300	Amperes
Peak One-Cycle Surge (Non-Repetitive) On-State Current (60Hz) ^①	I_{TSM}	3300	4000	5500	Amperes
Peak One-Cycle Surge (Non-Repetitive) On-State Current (50Hz) ^①	I_{TSM}	3000	3650	5000	Amperes
Critical Rate-of-Rise of On-State Current (Non-Repetitive) ^{① ② ③}	di/dt	800	800	800	Amperes/ μ s
Critical Rate-of-Rise of On-State Current (Repetitive)	di/dt	150	150	150	Amperes/ μ s
I^2t (for Fusing), 8.3 milliseconds	I^2t	45,000	64,400	120,000	A ² sec
Peak Gate Power Dissipation	P_{GM}	16	16	16	Watts
Average Gate Power Dissipation	$P_{G(av)}$	3	3	3	Watts
Storage Temperature	T_{STG}	-40 to 150	-40 to 150	-40 to 150	°C
Operating Temperature	T_J	-40 to 125	-40 to 125	-40 to 125	°C
Mounting Force ^④		1000 to 1400	1000 to 1400	1000 to 1400	lb.
Mounting Force ^④		450 to 635	450 to 635	450 to 635	kg

① Consult recommended mounting procedures.

② Applies for zero or negative gate bias.

③ Per JEDEC RS-397, 5.2.2.1.

④ With recommended gate drive.

⑤ Higher dv/dt ratings available, consult factory.

⑥ Per JEDEC standard RS-397, 5.2.2.6.



Powerex, Inc., Hillis Street, Youngwood, Pennsylvania 15697 (412) 925-7272
 Powerex Europe, S.A., 428 Ave. G. Durand, BP107, 72003 LeMans, France (43) 72.75.15

T620/T630
 Phase Control SCR
 150-300 Amperes Avg/100-1600 Volts

Electrical and Thermal Characteristics

Characteristics	Symbol	Test Conditions	T620	T620	T620	Units	
			_ _ 15	_ _ 20	_ _ 30		
			T630	T630	T630		
			_ _ 15	_ _ 20	_ _ 30		
Current—Conducting State Maximums							
Peak On-State Voltage	V_{TM}	$I_{TM} = 625A, T_J = 25^\circ C$	2.6	2.05	1.55	Volts	
			T620/T630				
Voltage—Blocking State Maximums[ⓐ]							
Forward Leakage, Peak	I_{DRM}	$T_J = 125^\circ C, V_{DRM} = \text{rated}$		25		mA	
Reverse Leakage, Peak	I_{RRM}	$T_J = 125^\circ C, V_{RRM} = \text{rated}$		25		mA	
Switching							
Typical Turn-Off Time	t_q	$I_T = 150A, T_J = 125^\circ C,$ $di_R/dt = 12.5A/\mu\text{sec},$ reapplied $dv/dt = 20V/\mu\text{sec}$ linear to $0.8V_{DRM}$		100		μsec	
Typical Turn-On Time [ⓑ]	t_{on}	$I_T = 100A, V_D = 100V$		5		μsec	
Min. Critical dv/dt exponential to V_{DRM} [ⓐ]	dv/dt	$T_J = 125^\circ C$		300		V/ μsec	
Thermal							
Maximum Thermal Resistance, [ⓐ] double sided cooling							
Junction to Case	$R_{\theta JC}$.08		$^\circ C/\text{Watt}$	
Case to Sink, Lubricated	$R_{\theta CS}$.02		$^\circ C/\text{Watt}$	
Gate—Maximum Parameters							
Gate Current to Trigger	I_{GT}	$T_J = 25^\circ C, V_D = 12V$		150		mA	
Gate Voltage to Trigger	V_{GT}	$T_J = 25^\circ C, V_D = 12V$		3		Volts	
Non-Trigging Gate Voltage	V_{GDM}	$T_J = 125^\circ C, \text{rated } V_{DRM}$.15		Volts	
Peak Forward Gate Current	I_{GTM}			4		Amperes	
Peak Reverse Gate Voltage	V_{GRM}			5		Volts	

ⓐ Consult recommended mounting procedures.

ⓑ Applies for zero or negative gate bias.

ⓐ Per JEDEC RS-397, 5.2.2.1.

ⓐ With recommended gate drive.

ⓐ Higher dv/dt ratings available, consult factory.

ⓐ Per JEDEC standard RS-397, 5.2.2.6.



Powerex, Inc., Hillis Street, Youngwood, Pennsylvania 15697 (412) 925-7272
 Powerex Europe, S.A., 428 Ave. G. Durand, BP107, 72003 LeMans, France (43) 72.75.15

T620/T630
Phase Control SCR
 150-300 Amperes Avg/100-1600 Volts

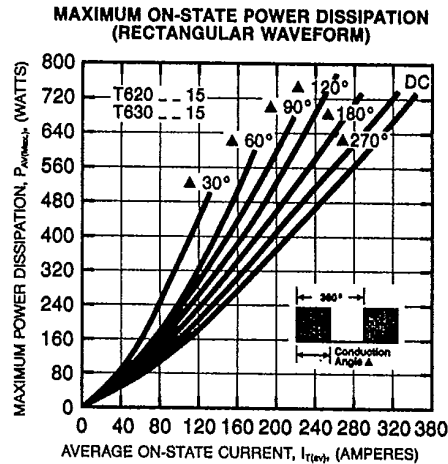
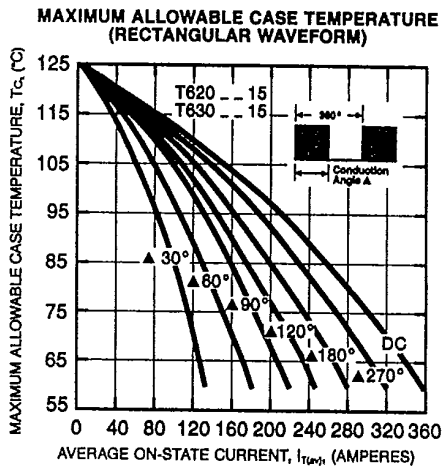
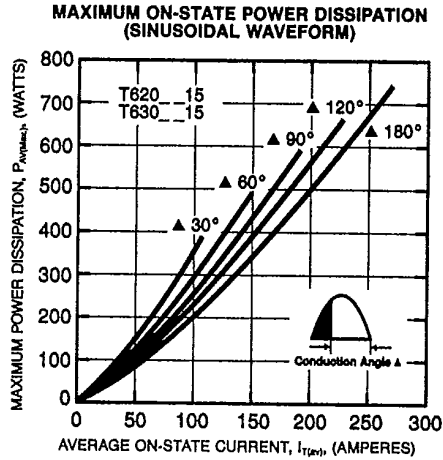
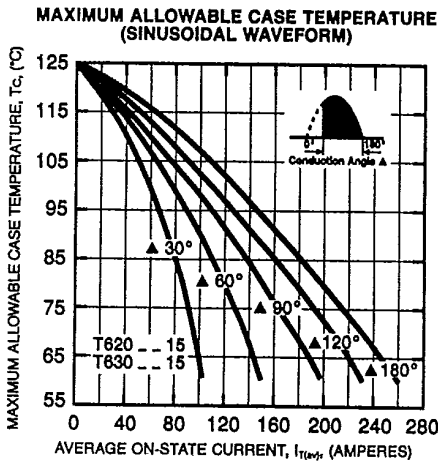
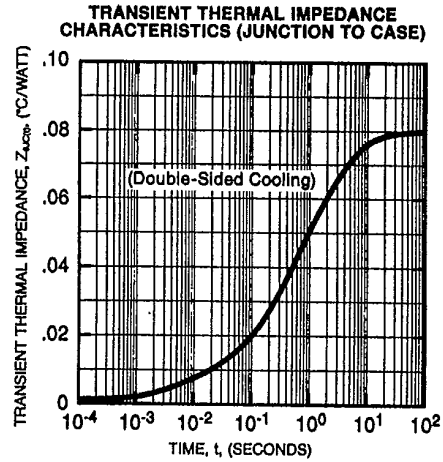
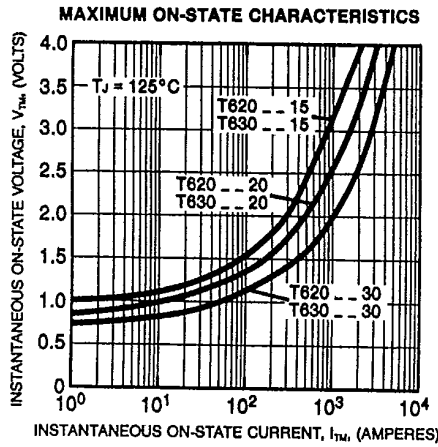



Powerex, Inc., Hillis Street, Youngwood, Pennsylvania 15697 (412) 925-7272

Powerex Europe, S.A., 428 Ave. G. Durand, BP107, 72003 LeMans, France (43) 72.75.15

T620/T630

Phase Control SCR

150-300 Amperes Avg/100-1600 Volts

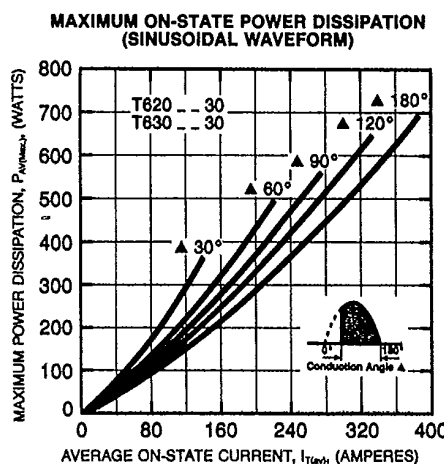
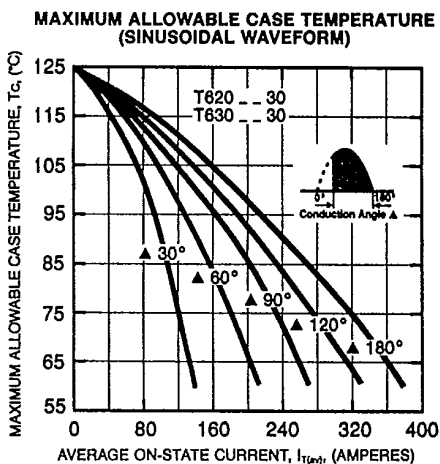
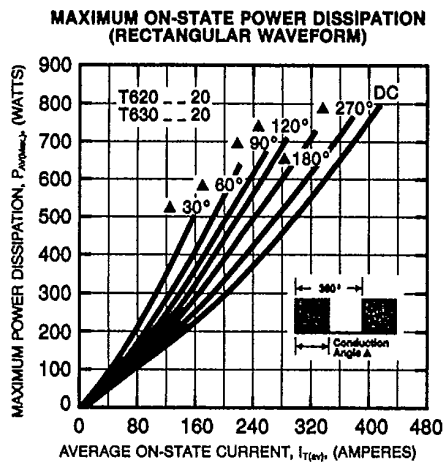
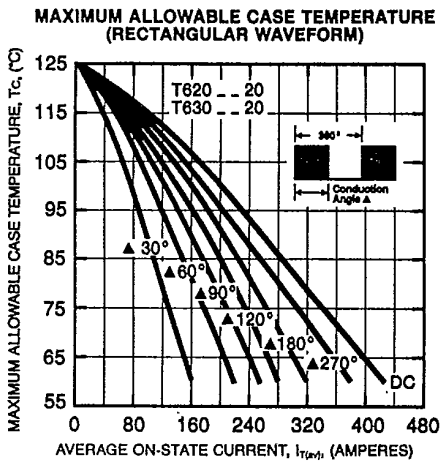
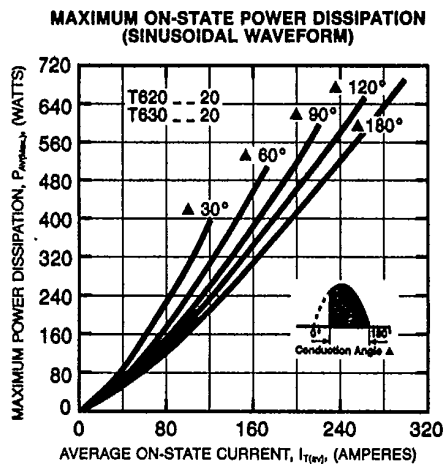
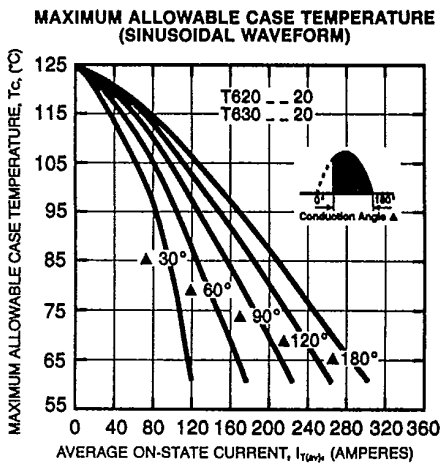



Powerex, Inc., Hillis Street, Youngwood, Pennsylvania 15697 (412) 925-7272
 Powerex Europe, S.A., 428 Ave. G. Durand, BP107, 72003 LeMans, France (43) 72.75.15

T620/T630
 Phase Control SCR
 150-300 Amperes Avg/100-1600 Volts

