

TOSHIBA BIPOLAR LINEAR INTEGRATED CIRCUIT SILICON MONOLITHIC

TA75071P, TA75071S**SINGLE OPERATIONAL AMPLIFIER**

The TA75071P and TA75071S are J-FET input low-noise operational amplifiers with low input bias and offset current, fast slew rate and wide bandwidth.

The TA75071P is pin compatible with the TA7504P and 741.

The TA75071S is single-in-line package.

The TA75071P series are excellent choice for active filters, integrators, buffers and sample-and-hold circuits.

FEATURES

- Low Input Bias Current : 200pA MAX.
- Low Input Offset Current : 50pA MAX.
- High Slew Rate : 13V / μ s
- Low Noise : 18nV / $\sqrt{\text{Hz}}$
- Wide Bandwidth : 3MHz
- Wide Supply Voltage Range : $\pm 4 \sim \pm 18$ V
- Internal Frequency Compensation
- Output Short Circuit Protection
- Offset Null Capability

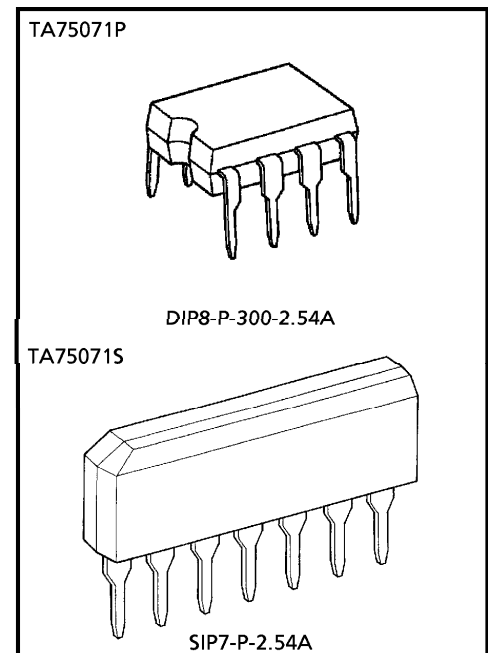
**Weight**

DIP8-P-300-2.54A : 0.5g (Typ.)
 SIP7-P-2.54A : 0.7g (Typ.)

961001EBA1

● TOSHIBA is continually working to improve the quality and the reliability of its products. Nevertheless, semiconductor devices in general can malfunction or fail due to their inherent electrical sensitivity and vulnerability to physical stress. It is the responsibility of the buyer, when utilizing TOSHIBA products, to observe standards of safety, and to avoid situations in which a malfunction or failure of a TOSHIBA product could cause loss of human life, bodily injury or damage to property. In developing your designs, please ensure that TOSHIBA products are used within specified operating ranges as set forth in the most recent products specifications. Also, please keep in mind the precautions and conditions set forth in the TOSHIBA Semiconductor Reliability Handbook.

● The products described in this document are subject to foreign exchange and foreign trade control laws.

● The information contained herein is presented only as a guide for the applications of our products. No responsibility is assumed by TOSHIBA CORPORATION for any infringements of intellectual property or other rights of the third parties which may result from its use. No license is granted by implication or otherwise under any intellectual property or other rights of TOSHIBA CORPORATION or others.

● The information contained herein is subject to change without notice.

PIN CONNECTION (TOP VIEW)

TA75071P

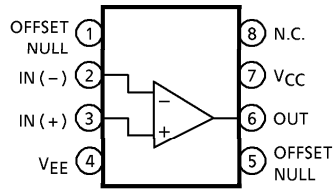

TA75071S

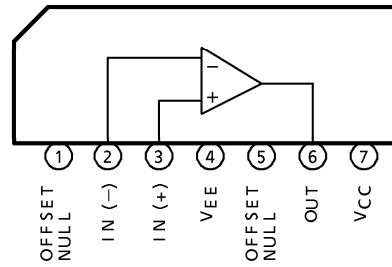

EQUIVALENT CIRCUIT

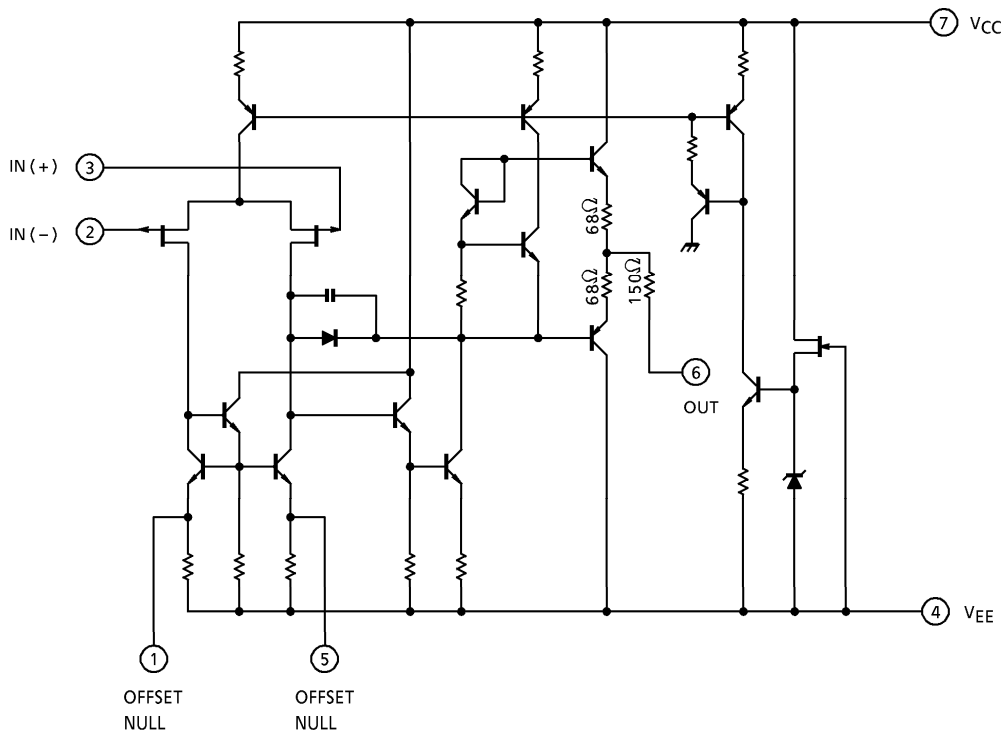

MAXIMUM RATINGS (Ta = 25°C)

CHARACTERISTIC	SYMBOL	RATING	UNIT
Supply Voltage	V _{CC}	+ 18	V
	V _{EE}	- 18	
Supply Voltage Surge)	DV _{IN}	± 30	V
Input Voltage	V _{IN}	± 15	V
Power Dissipation	P _D	500	mW
Operating Temperature	T _{opr}	- 40~85	°C
Storage Temperature	T _{stg}	- 50~125	°C

ELECTRICAL CHARACTERISTICS (V_{CC} = 15V, V_{EE} = - 15V, Ta = 25°C)

CHARACTERISTIC	SYMBOL	TEST CIR-CUIT	TEST CONDITION	MIN.	TYP.	MAX.	UNIT
Input Offset Voltage	V _{IO}	—	R _g ≤ 10kΩ	—	3	10	mV
TC Of Input Offset Voltage	TCV _{IO}	—	—	—	10	—	μV / °C
Input Offset Current	I _{IO}	—	—	—	10	50	pA
Input Bias Current	I _I	—	—	—	30	200	pA
Common Mode Input Voltage	CMV _{IN}	—	—	± 11	± 12	—	V
Maximum Output Voltage	V _{OM}	—	R _L = 10kΩ	24	—	—	V _{p-p}
	V _{OMR}	—	R _L = 2kΩ	20	24	—	
Voltage Gain (Open Loop)	G _V	—	V _{OUT} = ± 10V, R _L = 2kΩ	25	200	—	V / mV
Unity Gain Cross Frequency	f _T	—	Open Loop, R _L = 10kΩ	—	3	—	MHz
Input Resistance	R _{IN}	—	—	—	10 ¹²	—	Ω
Common Mode Input Signal Rejection Ratio	CMRR	—	R _g ≤ 10kΩ	70	76	—	dB
Supply Voltage Rejection Ratio	SVRR	—	R _g ≤ 10kΩ	70	76	—	dB
Supply Current	I _{CC} , I _{EE}	—	Non Load	—	1.4	2.5	mA

OPERATING CHARACTERISTICS (V_{CC} = 15V, V_{EE} = - 15V, Ta = 25°C)

CHARACTERISTIC	SYMBOL	TEST CIR-CUIT	TEST CONDITION	MIN.	TYP.	MAX.	UNIT
Slew Rate	SR	—	V _{IN} = 10V _{p-p} , R _L = 2kΩ C _L = 100pF	—	13	—	V / μs
Equivalent Input Noise Voltage	V _{NI}	—	R _S = 100Ω	f = 1kHz	—	18	nV / √Hz
				f = 10Hz~10kHz	—	4	μV _{rms}
Equivalent Input Noise Current	I _{NI}	—	R _S = 100Ω, f = 1kHz	—	0.01	—	pA / √Hz
Total Harmonic Distortion	THD	—	V _{OUT} = 10V _{rms} , R _S ≤ 1kΩ R _L ≥ 2kΩ, f = 1kHz	—	0.01	—	%

CHARACTERISTICS

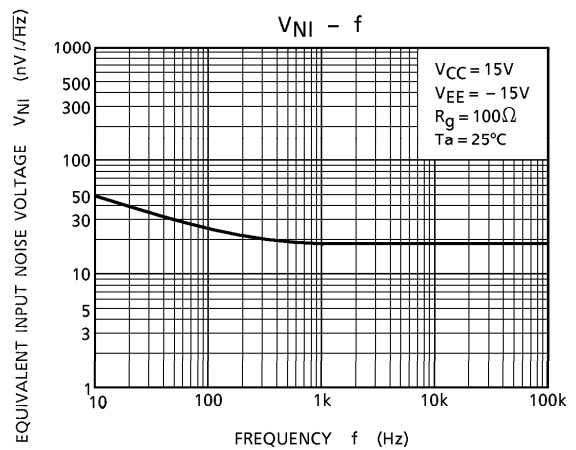
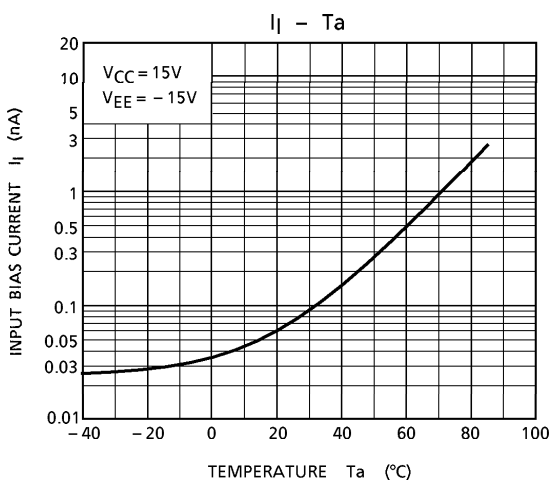
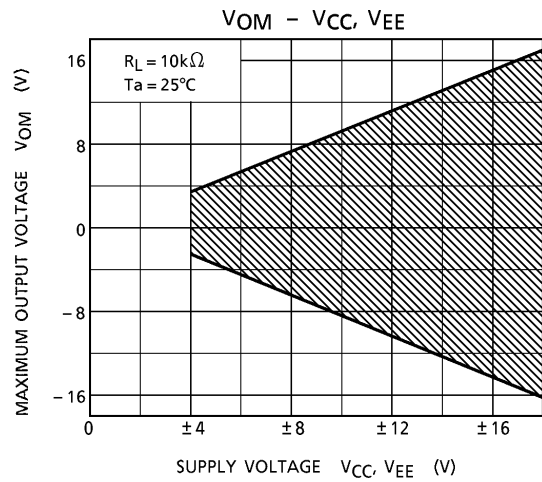
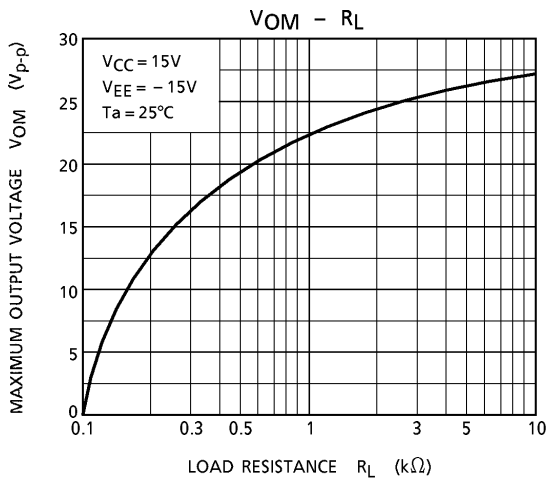
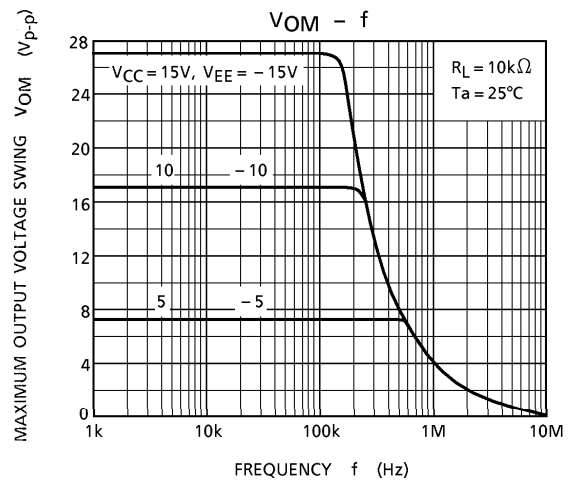
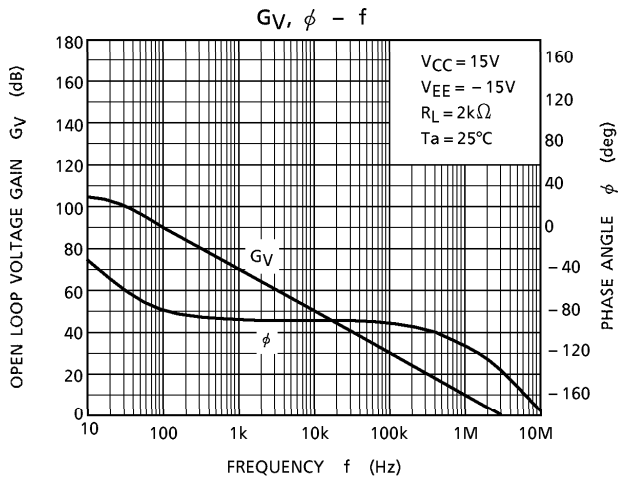

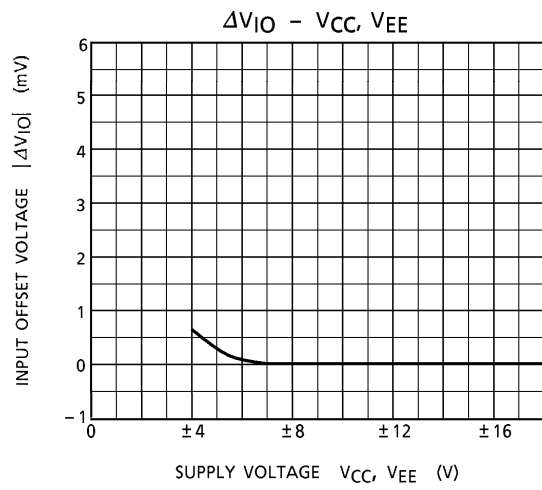
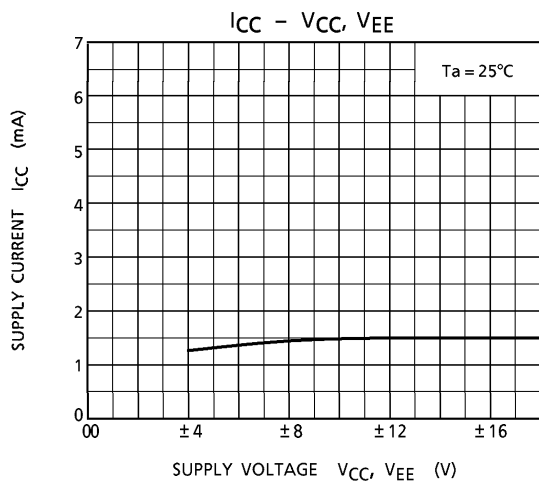

OUTLINE DRAWING
DIP8-P-300-2.54A

Unit : mm

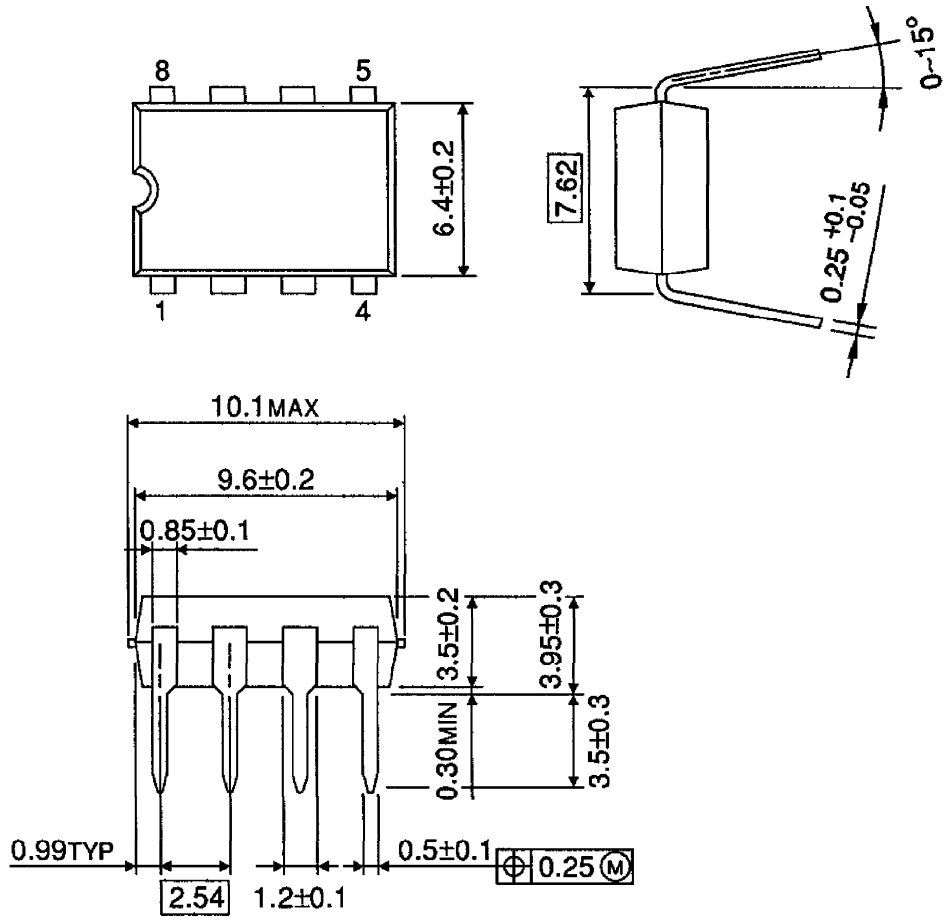

Weight : 0.5g (Typ.)

OUTLINE DRAWING
SIP7-P-2.54A

Unit : mm

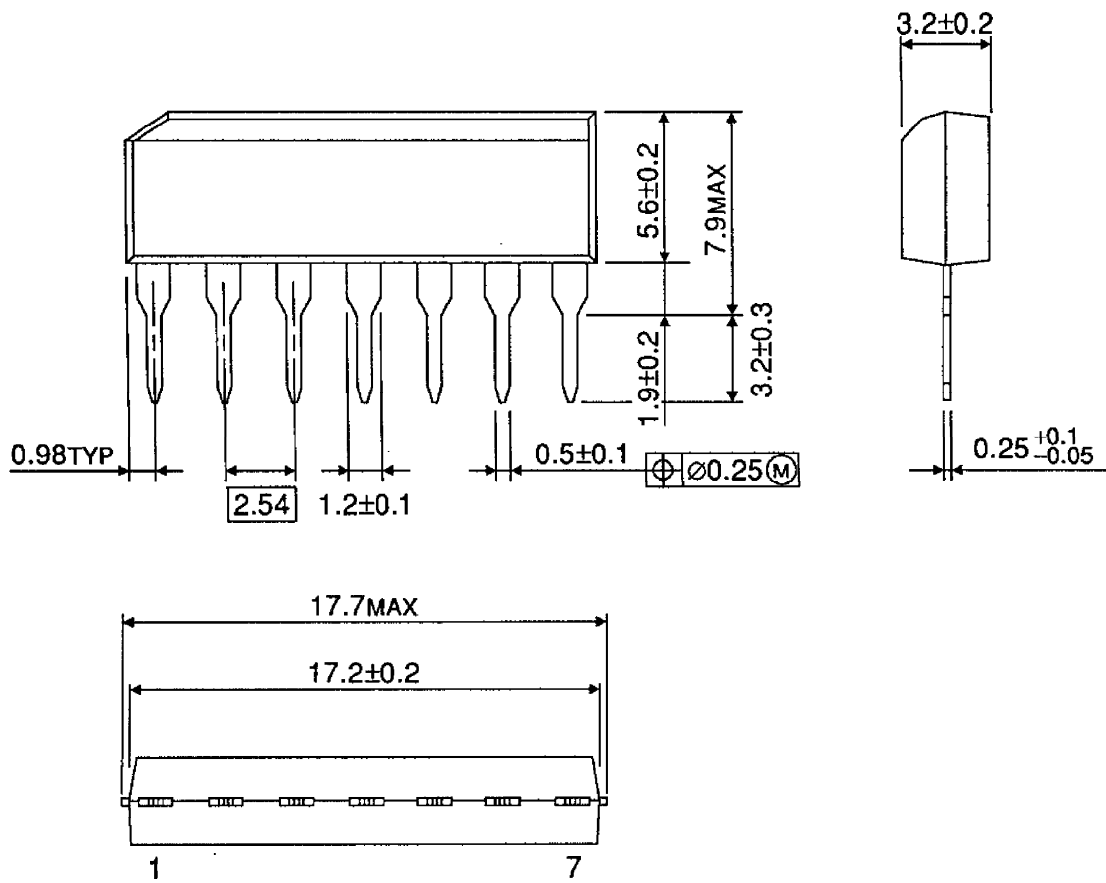

Weight : 0.7g (Typ.)