

LH52256CN-10LL

256K SRAM

(Model No.: LH525C9N)

Spec No.: EL081022A

Issue Date: May 24, 1996

- Handle this document carefully for it contains material protected by international copyright law. Any reproduction, full or in part, of this material is prohibited without the express written permission of the company.
- When using the products covered herein, please observe the conditions written herein and the precautions outlined in the following paragraphs. In no event shall the company be liable for any damages resulting from failure to strictly adhere to these conditions and precautions.

(1) The products covered herein are designed and manufactured for the following application areas. When using the products covered herein for the equipment listed in Paragraph (2), even for the following application areas, be sure to observe the precautions given in Paragraph (2). Never use the products for the equipment listed in Paragraph (3).

- Office electronics
- Instrumentation and measuring equipment
- Machine tools
- Audiovisual equipment
- Home appliances
- Communication equipment other than for trunk lines

(2) Those contemplating using the products covered herein for the following equipment which demands high reliability, should first contact a sales representative of the company and then accept responsibility for incorporating into the design fail-safe operation, redundancy, and other appropriate measures for ensuring reliability and safety of the equipment and the overall system.

- Control and safety devices for airplanes, trains, automobiles, and other transportation equipment
- Mainframe computers
- Traffic control systems
- Gas leak detectors and automatic cutoff devices
- Rescue and security equipment
- Other safety devices and safety equipment, etc.

(3) Do not use the products covered herein for the following equipment which demands extremely high performance in terms of functionality, reliability, or accuracy.

- Aerospace equipment
- Communications equipment for trunk lines
- Control equipment for the nuclear power industry
- Medical equipment related to life support, etc.

(4) Please direct all queries and comments regarding the interpretation of the above three Paragraphs to a sales representative of the company.

- Please direct all queries regarding the products covered herein to a sales representative of the company.

Contents

1. Description	2
2. Pin Configuration	2
3. Truth Table	3
4. Block Diagram	3
5. Absolute Maximum Ratings	4
6. Recommended DC Operating Conditions	4
7. DC Electrical Characteristics	4
8. AC Electrical Characteristics	5
9. Data Retention Characteristics	6
10. Pin Capacitance	6
11. Timing Chart	7
12. Package and Packing Specification	10

3. Truth Table

\overline{CE}	\overline{WE}	\overline{OE}	Mode	I/O ₁ to I/O ₈	Supply current
H	*	*	Standby	High impedance	Standby (I_{SB})
L	H	L	Read	Data output	Active (I_{CC})
L	H	H	Output disable	High impedance	Active (I_{CC})
L	L	*	Write	Data Input	Active (I_{CC})

(* = Don't Care, L=Low, H=High)

4. Block Diagram

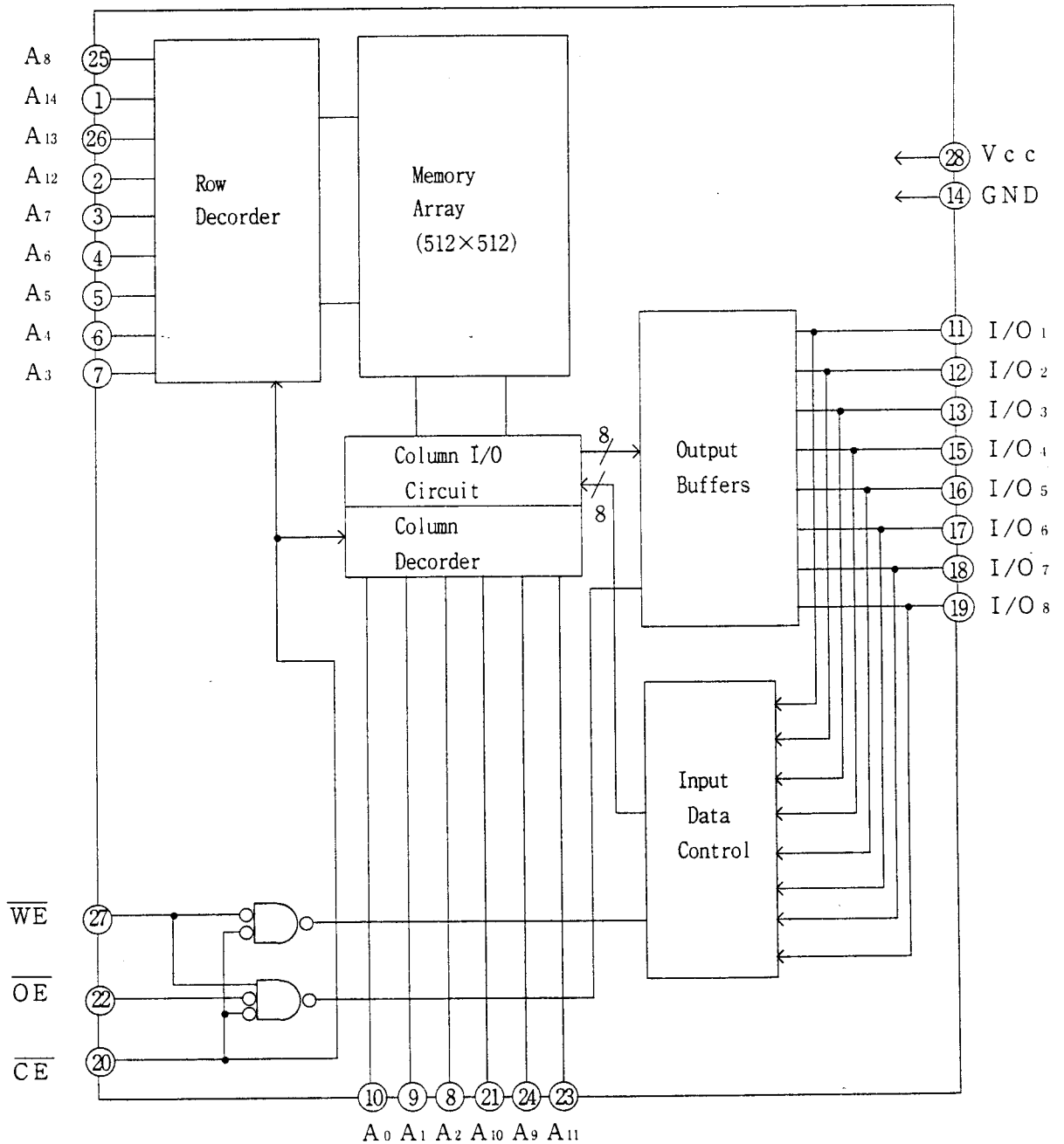

5. Absolute Maximum Ratings

Parameter	Symbol	Ratings	Unit
Supply voltage (*1)	V _{CC}	-0.5 to +7.0	V
Input voltage (*1)	V _{IN}	-0.5 (*2) to V _{CC} +0.5	V
Operating temperature	T _{OPR}	0 to +70	°C
Storage temperature	T _{STG}	-65 to +150	°C

Note) *1. The maximum applicable voltage on any pin with respect to GND.

*2. Undershoot of -3.0V is allowed width of pulse below 50ns.

6. Recommended DC Operating Conditions

(T_a = 0°C to +70°C)

Parameter	Symbol	Min.	Typ.	Max.	Unit
Supply voltage	V _{CC}	4.5	5.0	5.5	V
Input voltage	V _{IH}	2.2		V _{CC} +0.5	V
	V _{IL}	-0.5 (*3)		0.8	V

Note) *3. Undershoot of -3.0V is allowed width of pulse below 50ns.

7. DC Electrical Characteristics

(T_a = 0°C to +70°C, V_{CC} = 4.5V to 5.5V)

Parameter	Symbol	Conditions	Min.	Typ. (*4)	Max.	Unit
Input leakage current	I _{LI}	V _{IN} = 0V to V _{CC}	-1.0		1.0	μA
Output leakage current	I _{LO}	$\overline{CE} = V_{IH}$ or $\overline{OE} = V_{IH}$ V _{I/O} = 0V to V _{CC}	-1.0		1.0	μA
Operating supply current	I _{CC}	Minimum cycle V _{IN} = V _{IL} or V _{IH} , I _{I/O} = 0mA, $\overline{CE} = V_{IL}$		20	40	mA
	I _{CC1}	t _{RC} , t _{WC} = 1μs V _{IN} = V _{IL} or V _{IH} , I _{I/O} = 0mA, $\overline{CE} = V_{IL}$			10	mA
Standby current	I _{SB}	$\overline{CE} \geq V_{CC} - 0.2V$		0.6	40	μA
	I _{SB1}	$\overline{CE} = V_{IH}$			3	mA
Output voltage	V _{OL}	I _{OL} = 2.1mA			0.4	V
	V _{OH}	I _{OH} = -1.0mA	2.4			V

Note) *4. Typical values at V_{CC} = 5.0V, T_a = 25°C.

8. AC Electrical Characteristics

AC Test Conditions

Input pulse level	0.6 V to 2.4 V
Input rise and fall time	10 ns
Input and Output timing Ref. level	1.5 V
Output load	1 TTL + C _L (100 pF) (*5)

Note) *5. Including scope and jig capacitance.

Read cycle

(T_a = 0°C to +70°C, V_{cc} = 4.5 V to 5.5 V)

Parameter	Symbol	Min.	Max.	Unit	
Read cycle time	t _{RC}	100		ns	
Address access time	t _{AA}		100	ns	
CE access time	t _{ACE}		100	ns	
Output enable to output valid	t _{OE}		50	ns	
Output hold from address change	t _{OH}	10		ns	
CE Low to output active	t _{OLZ}	10		ns	*6
OE Low to output active	t _{OLZ}	5		ns	*6
CE High to output in High impedance	t _{HZ}	0	40	ns	*6
OE High to output in High impedance	t _{OHZ}	0	40	ns	*6

Write cycle

(T_a = 0°C to +70°C, V_{cc} = 4.5 V to 5.5 V)

Parameter	Symbol	Min.	Max.	Unit	
Write cycle time	t _{wc}	100		ns	
CE Low to end of write	t _{cw}	80		ns	
Address valid to end of write	t _{aw}	80		ns	
Address setup time	t _{as}	0		ns	
Write pulse width	t _{wp}	75		ns	
Write recovery time	t _{wr}	0		ns	
Input data setup time	t _{dw}	40		ns	
Input data hold time	t _{dh}	0		ns	
WE High to output active	t _{ow}	5		ns	*6
WE Low to output in High impedance	t _{wz}	0	40	ns	*6
OE High to output in High impedance	t _{ohz}	0	40	ns	*6

Note) *6. Active output to High impedance and High impedance to output active tests specified for a ±200mV transition from steady state levels into the test load.

9. Data Retention Characteristics

(Ta= 0°C to +70°C)

Parameter	Symbol	Conditions	Min.	Typ. (*7)	Max.	Unit
Data Retention supply voltage	V _{CCDR}	$\overline{CE} \geq V_{CCDR} - 0.2V$	2.0		5.5	V
Data Retention supply current	I _{CCDR}	V _{CCDR} = 3V	Ta = 25°C	0.3	1.0	μA
			Ta = 40°C		3.0	μA
		$\overline{CE} \geq V_{CCDR} - 0.2V$			1.5	μA
Chip enable setup time	t _{CDR}		0			ns
Chip enable hold time	t _R		(*8) t _{RC}			ns

Note) *7. Typical values at Ta=25°C

*8. Read Cycle

10. Pin Capacitance

(Ta= 25°C, f = 1MHz)

Parameter	Symbol	Conditions	Min.	Typ.	Max.	Unit
Input capacitance	C _{IN}	V _{IN} = 0V			7	pF *9
I/O capacitance	C _{I/O}	V _{I/O} = 0V			10	pF *9

Note) *9. This parameter is sampled and not production tested.

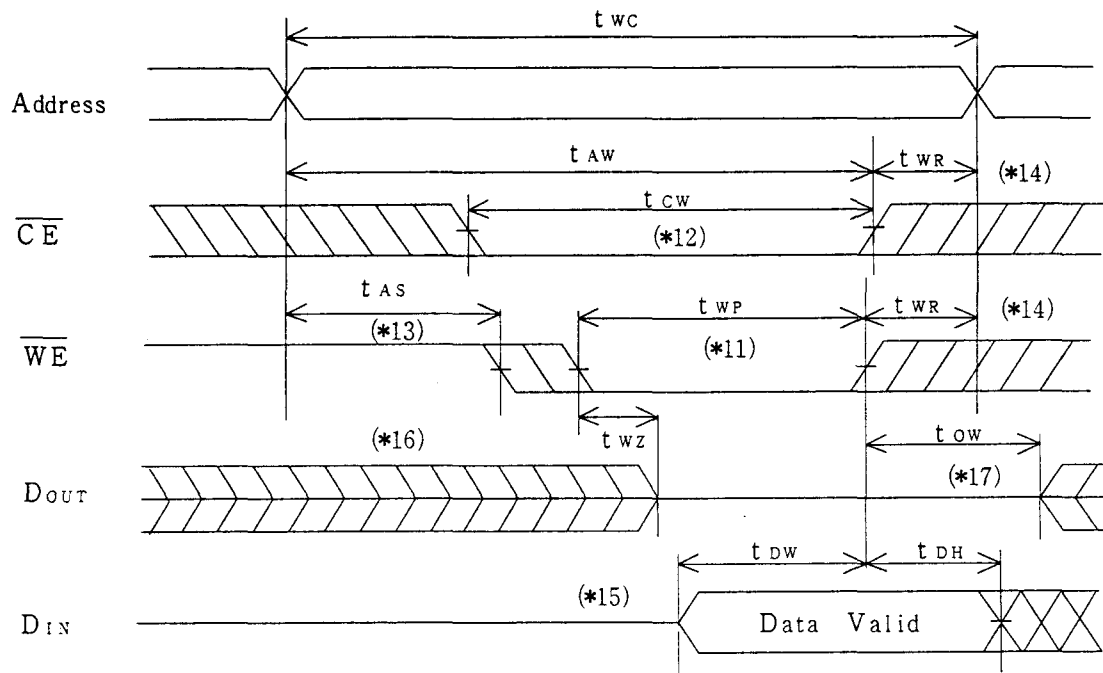
Write cycle timing chart — (\overline{OE} Low fixed)

- Note) * 11. A write occurs during the overlap of a low \overline{CE} , and a low \overline{WE} .
 A write begins at the latest transition among \overline{CE} going low, and \overline{WE} going low.
 A write ends at the earliest transition among \overline{CE} going high, and \overline{WE} going high.
 t_{wp} is measured from the beginning of write to the end of write.
- * 12. t_{cw} is measured from the later of \overline{CE} going low to the end of write.
- * 13. t_{as} is measured from the address valid to the beginning of write.
- * 14. t_{wr} is measured from the end of write to the address change.
- * 15. During this period, I/O pins are in the output state, therefore the input signals of opposite phase to the outputs must not be applied.
- * 16. If \overline{CE} goes low simultaneously with \overline{WE} going low or after \overline{WE} going low, the outputs remain in high impedance state.
- * 17. If \overline{CE} goes high simultaneously with \overline{WE} going high or before \overline{WE} going high, the outputs remain in high impedance state.

Data Retention timing chart - (\overline{CE} Controlled)

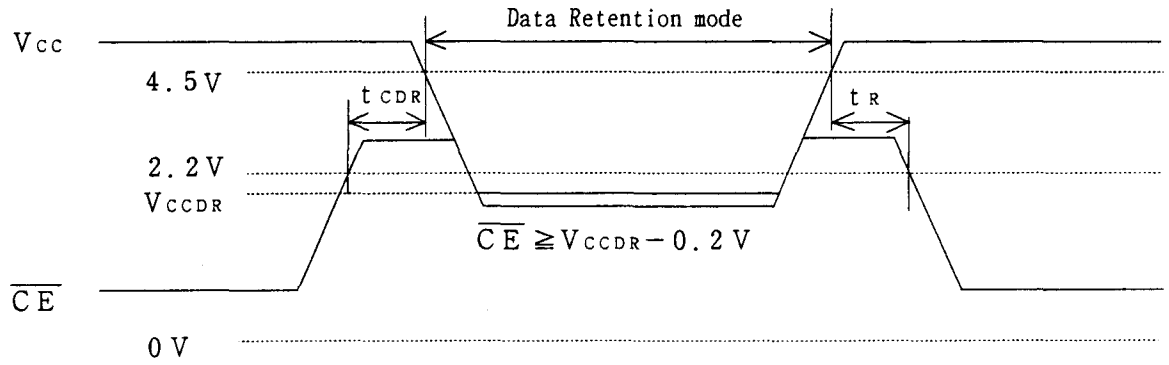

11 Package and packing specification

1. Package Outline Specification

Refer to drawing No. AA 9 3 1

2. Markings

2-1. Marking contents

- (1) Product name : LH52256CN-10LL
- (2) Company name : SHARP
- (3) Date code

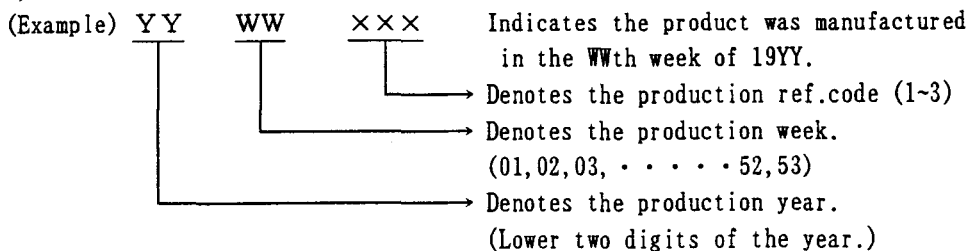

(4) The marking of "JAPAN" indicates the country of origin.

2-2. Marking layout

Refer to drawing No. AA 9 3 1

(This layout do not define the dimensions of marking character and marking position.)

3. Packing Specification (Dry packing for surface mount packages)

Dry packing is used for the purpose of maintaining IC quality after mounting packages on the PCB (Printed Circuit Board).

When the epoxy resin which is used for plastic packages is stored at high humidity, it may absorb 0.15% or more of its weight in moisture. If the surface mount type package for a relatively large chip absorbs a large amount of moisture between the epoxy resin and insert material (e.g. chip, lead frame) this moisture may suddenly vaporize into steam when the entire package is heated during the soldering process (e.g. VPS). This causes expansion and results in separation between the resin and insert material, and sometimes cracking of the package. This dry packing is designed to prevent the above problem from occurring in surface mount packages.

3-1. Packing Materials

Material Name	Material Specificaiton	Purpose
Magazine	Anti-static treated plastic (25devices/magazine)	Packing of device
Stopper	Plastic or rubber	Fixing of device
Cap	Plastic (2caps/bag)	Fixing of Magazine
Laminated aluminum bag	Aluminum polyethylene (1bag/case)	Drying of device
Desiccant	Silica gel	Drying of device
Inner case	Card board (1000devices/case)	Packaging of device
Label	Paper	Indicates part number, quantity and date of manufacture
Outer case	Card board	Outer packing of Magazine

(Devices shall be inserted into a magazine (sleeve) in the same direction.)

3-2. Outline dimension of magazine (sleeve)

Refer to attached drawing

4. Storage and Opening of Dry Packing

4-1. Store under conditions shown below before opening the dry packing

- (1) Temperature range : 5~40°C
- (2) Humidity : 80% RH or less

4-2. Notes on opening the dry packing

- (1) Before opening the dry packing, prepare a working table which is grounded against ESD and use a grounding strap.
- (2) The magazine has been treated to be conductive or anti-static. If the device is transferred to another magazine, use a equivalent magazine.
- (3) A stopper is included with the magazine. Before storage, make sure the stopper is inserted.

4-3. Storage after opening the dry packing

Perform the following to prevent absorption of moisture after opening.

- (1) After opening the dry packing, store the ICs in an environment with a temperature of 5~25°C and a relative humidity of 60% or less and mount ICs within 4 days after opening dry packing.
- (2) To re-store the ICs for an extended period of time within 4 days after opening the dry packing, use a dry box or re-seal the ICs in the dry packing with desiccant (whoes indicator is blue), and store in an environment with a temperature of 5~40°C and a relative humidity of 80% or less, and mount ICs within 2 weeks.
- (3) Total period of storage after first opening and re-opening is within 4 days, and store the ICs in the same environment as section 4-3.(1).

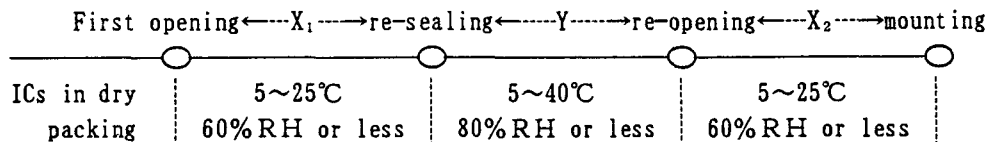

$X_1 + X_2$: within 4 days Y : within 2 weeks

4-4. Baking (drying) before mounting

- (1) Baking is necessary
 - (A) If the humidity indicator in the desiccant becomes pink
 - (B) If the procedure in section 4-3 could not be performed
- (2) Recommended baking conditions

If the above conditions (A) and (B) are applicable, bake it before mounting. The recommended conditions are 16~24 hours at 120°C or 5~10 hours at 150°C. Note that the standard magazine can not be baked. Use the heat resistant magazine.
- (3) Storage after baking

After baking ICs, store the ICs in the same environment as section 4-3.(1).

5. Surface Mount Conditions

Please perform the following conditions when mounting ICs not to deteriorate IC quality.

5-1. Soldering conditions (The following conditions are valid only for one time soldering.)

Mounting Method	Temperature and Duration	Measurement Point
Reflow soldering (air)	Peak temperature of 240°C, duration less than 15 seconds above 230°C, temperature increase rate of 1~4°C/second	IC surface
Solder dipping	245°C or less, duration less than 3 seconds/dip, total of 5 seconds	Solder bath
Vapor phase soldering	215°C or less, duration less than 40 seconds above 200°C	Steam
Manual soldering (soldering iron)	260°C or less, duration less than 10 seconds	IC outer lead surface

5-2. Conditions for removal of residual flux

- (1) Ultrasonic washing power : 25 Watts/liter or less
- (2) Washing time : Total 1 minute maximum
- (3) Solvent temperature : 15~40°C

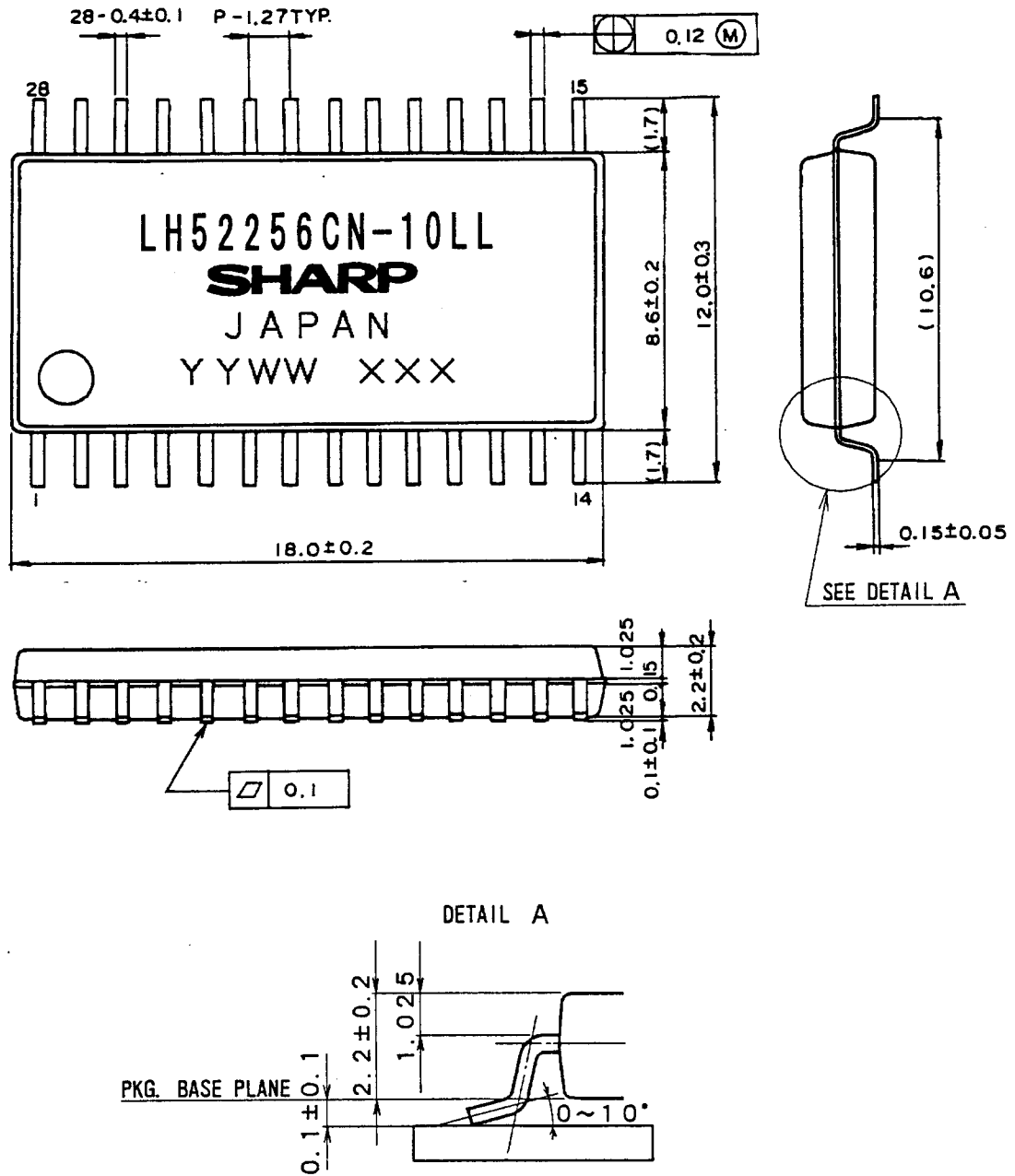

名称 NAME	SOP28-P-450	リード仕上 LEAD FINISH	TIN-LEAD PLATING	備考 NOTE	プラスチックパッケージ外形寸法は、バリを含まないものとする。 Plastic body dimensions do not include burr of resin.
DRAWING NO.	AA931	単位 UNIT	mm		

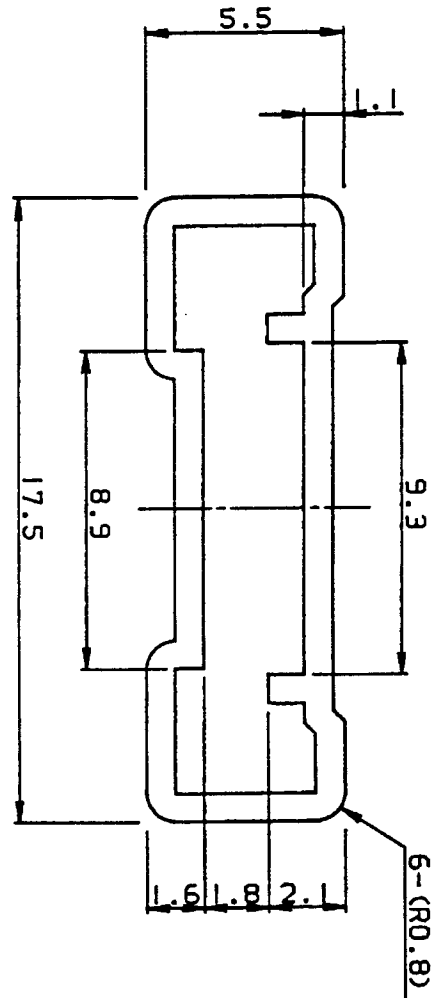
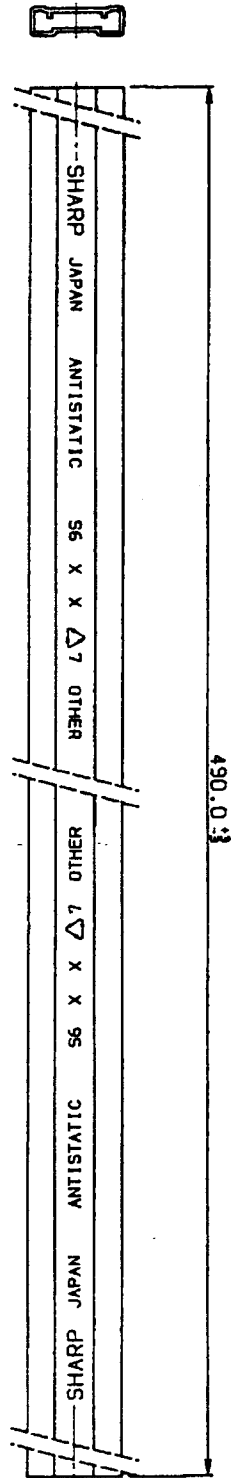

注記 : マガジン(スリーブ)両側のストッパーは、ゴムストッパーとする。
指示無き寸法公差は全て±0.4mmとする。

NOTES : Stopper which is set at the both ends of magazine (sleeve) is made of rubber.
All tolerances are ±0.4mm unless otherwise specified.

名称 NAME	SOP28SPN-A2			備考
DRAWING NO.	CV607	単位 UNIT	mm	

STATIC SRAM RAM Random Access Memory Low Power SOP LH52256CN-10LL 256K (32K x 8)