

CXD3030R

A CD-ROM playback speed of 48× has finally been achieved.

We can say that the CD-ROM has reached the transfer rates of hard disks only a few years ago.

The CD-ROM is now indispensable in personal computers for installing application software.

The CXD3030R system-on-a-Chip (SoC) product represents an optimal selection for compact basic design, energy-saving design, and increased speed.

- Implements all the digital signal processing required for playback in a single chip.
- Integrates digital servo control, digital signal processing, a CD-ROM decoder, ATAPI interface, and DRAM on a single chip.
- Playback speeds: Up to 48×
- Provides even higher mounting densities by including on-chip RAM.

The CXD3030R is a system-on-a-Chip (SoC) product that integrates digital servo control, digital signal processing, a CD-ROM decoder, ATAPI interface, and DRAM on a single chip. It supports playback speeds up to 48×

■ Digital Servo Control

While the CD-ROM optical system includes several adjustment points, the CXD3030R can automatically set all of these to optimal values. It includes a 6-stage cascaded digital filter as the tracking filter, and can flexibly support different pickups and playback speeds. The inclusion of an on-chip wide capture PLL circuit allows the CXD3030R to be freely set up to get the maximum performance from the drive mechanism, providing support for both CAV techniques using an FG signal, and partial CAV techniques that take into account the limitations on the speeds the motor can provide. A drive with a short access time can be designed by using the mode in which the VCO is controlled by a microcomputer and the pull-in time after access is minimized.

■ Digital Signal Processing

The CXD3030R supports playback speeds up to 48×. Since this speed is 48 times the speed at which audio CDs are played back, the CD-ROM certainly has progressed to surprising speeds. The built-in buffered audio play function allows this device to play back CD-DA audio while actually reading the disc in high-speed CAV mode. An extensive set of power saving functions are also provided since an increasingly high percentage of notebook personal computers include a CD-ROM drive. In addition to providing functions that lower power consumption in the standby state, this device also achieves reduced power consumption during playback.

■ ATAPI

Sony has led the industry by integrating on a single chip an interface and a decoder that support ATAPI ULTRA DMA (33). It goes without saying that the CXD3030R implements all related operations even while reaching a speed of 48×

V O I C E

When I joined Sony, 2× speed drives had just been released. It's impressive how far we've come since then. Although the economy has its ups and downs, technology is always progressing. While I know that my fantasies of my salary increasing as fast as technology are unreasonable, I am aware that technology has advanced this far through the efforts of many people in many areas. I recommend that you experience this speed directly.



*New
Products*

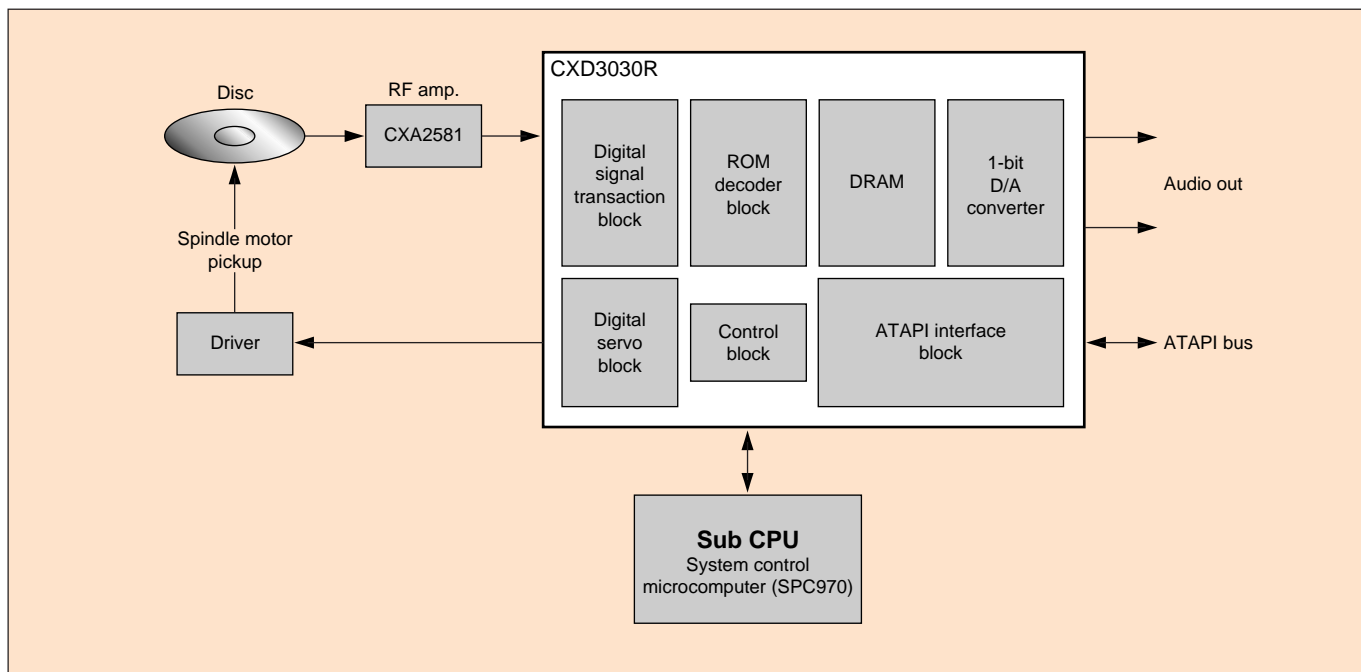

■ Figure 1 System Block Diagram for 48x Speed CD-ROM System-on-a-Chip LSI System

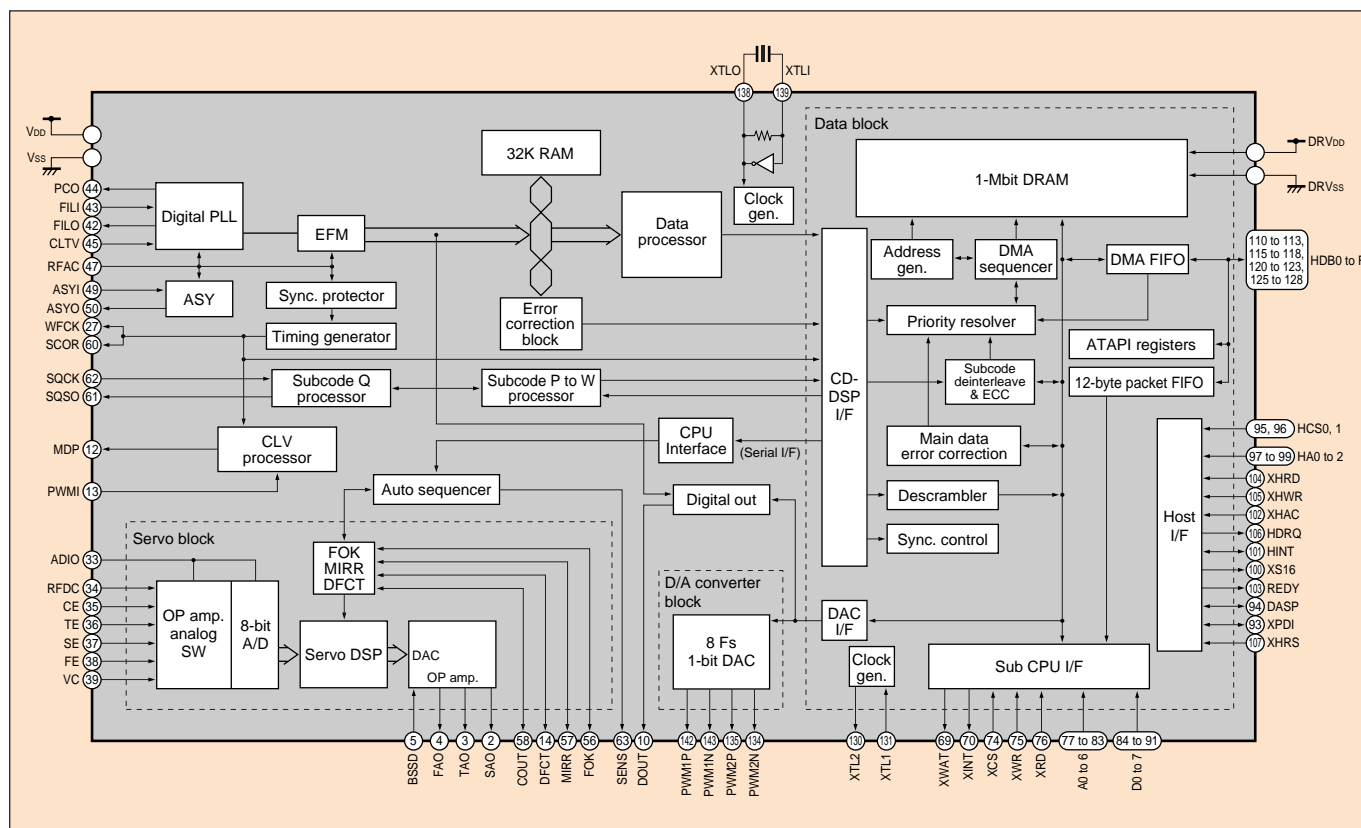

■ Figure 2 CXD3030R Block Diagram