



MIC2196

400kHz SO-8 Boost Control IC

Final Information

General Description

Micrel's MIC2196 is a high efficiency PWM boost control IC housed in a SO-8 package. The MIC2196 is optimized for low input voltage applications. With its wide input voltage range of 2.9V to 14V, the MIC2196 can be used to efficiently boost voltages in 3.3V, 5V, and 12V systems, as well as 1- or 2-cell Li Ion battery powered applications. Its powerful 2Ω output driver allows the MIC2196 to drive large external MOSFETs.

The MIC2196 is ideal for space-sensitive applications. The device is housed in the space-saving SO-8 package, whose low pin-count minimizes external components. Its 400kHz PWM operation allows a small inductor and small output capacitors to be used. The MIC2196 can implement all-ceramic capacitor solutions.

Efficiencies over 90% are achievable over a wide range of load conditions with the MIC2196's PWM boost control scheme. Its fixed frequency PWM architecture also makes the MIC2196 ideal for noise-sensitive telecommunications applications.

MIC2196 features a low current shutdown mode of 1μA and programmable undervoltage lockout.

The MIC2196 is available in an 8-pin SOIC package with a junction temperature range from -40°C to +125°C.

Features

- 2.9V to 14V input voltage range
- >90% efficiency
- 2Ω output driver
- 400kHz oscillator frequency
- PWM current mode control
- 0.5μA micro power shutdown
- Programmable UVLO
- Front edge blanking
- Cycle-by-cycle current limiting
- Frequency foldback short-circuit protection
- 8-pin SOIC package

Applications

- Step-up conversion in telecom/datacom systems
- SLIC power supplies
- SEPIC power supplies
- Low input voltage flyback and forward converters
- Wireless modems
- Cable modems
- ADSL line cards
- Base stations
- 1-and 2-cell Li Ion battery operated equipment

Typical Application

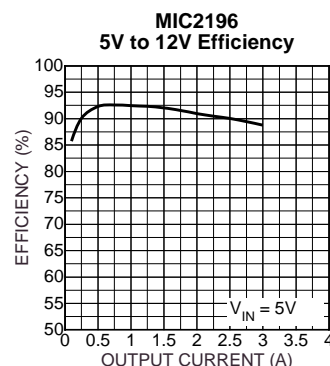
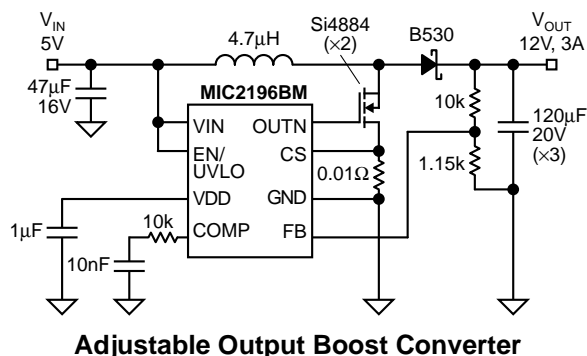

Ordering Information

Part Number Standard	Part Number Pb-Free	Output Voltage	Frequency	Junction Temp. Range	Package
MIC2196BM	MIC2196YM	Adjustable	400KHz	-40°C to +125°C	8-lead SOIC

Pin Configuration

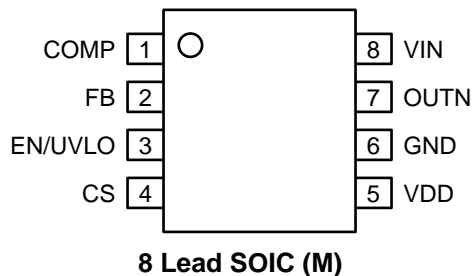

Pin Description

Pin Number	Pin Name	Pin Function
1	COMP	Compensation (Output): Internal error amplifier output. Connect to a capacitor or series RC network to compensate the regulator's control loop.
2	FB	Feedback (Input): Regulates FB to 1.245V.
3	EN/UVLO	Enable/Undervoltage Lockout (input): A low level on this pin will power down the device, reducing the quiescent current to under 0.5 μ A. This pin has two separate thresholds, below 1.5V the output switching is disabled, and below 0.9V the device is forced into a complete micropower shutdown. The 1.5V threshold functions as an accurate undervoltage lockout (UVLO) with 100mV hysteresis.
4	CS	The (+) input to the current limit comparator. A built in offset of 100mV between CS and GND in conjunction with the current sense resistor sets the current limit threshold level. This is also the (+) input to the current amplifier.
5	VDD	3V internal linear-regulator output. VDD is also the supply voltage bus for the chip. Bypass to GND with 1 μ F.
6	GND	Ground.
7	OUTN	High current drive for N channel MOSFET. Voltage swing is from ground to VIN. R _{ON} is typically 3 Ω @ 5V _{IN} .
8	VIN	Input voltage to the control IC. This pin also supplies power to the gate drive circuit.

Absolute Maximum Ratings (Note 1)

Supply Voltage (V_{IN})	15V
Digital Supply Voltage (V_{DD})	7V
Comp Pin Voltage (V_{COMP})	-0.3V to +3V
Feedback Pin Voltage (V_{FB})	-0.3V to +3V
Enable Pin Voltage ($V_{EN/UVLO}$)	-0.3V to 15V
Current Sense Voltage (V_{CS})	-0.3V to +1V
Power Dissipation (P_D)	285mW @ $T_A = 85^\circ\text{C}$
Ambient Storage Temperature	-65°C to +150°C
ESD Rating, Note3	2kV

Operating Ratings (Note 2)

Supply Voltage (V_{IN})	+2.9V to +14V
Junction Temperature	-40°C ≤ T_J ≤ +125°C
Package Thermal Resistance	
θ_{JA} 8-lead SOIC	140°C/W

Electrical Characteristics

$V_{IN} = 5V$, $V_{OUT} = 12V$, $T_A = 25^\circ\text{C}$. **Bold** values indicate $-40^\circ\text{C} < T_J < +125^\circ\text{C}$; unless otherwise specified.

Parameter	Condition	Min	Typ	Max	Units
Regulation					
Feedback Voltage Reference	(±1%)	1.233	1.245	1.258	V
	(±2%)	1.220	1.245	1.270	V
Feedback Bias Current			50		nA
Output Voltage Line Regulation	$3V \leq V_{IN} \leq 9V$		+0.08		% / V
Output Voltage Load Regulation	$0mV \leq V_{CS} \leq 75mV$		-1.2		%
Output Voltage Total Regulation	$3V \leq V_{IN} \leq 9V$; $0mV \leq V_{CS} \leq 75mV$ (±3%)	1.208		1.282	V
Input & V_{DD} Supply					
V_{IN} Input Current (I_Q)	(excluding external MOSFET gate current)		1	2	mA
Shutdown Quiescent Current	$V_{EN/UVLO} = 0V$		0.5	5	μA
Digital Supply Voltage (V_{DD})	$I_L = 0$	2.82	3.0	3.18	V
Digital Supply Load Regulation	$I_L = 0$ to 5mA		0.1		V
Undervoltage Lockout	V_{DD} upper threshold (turn on threshold)		2.65		V
UVLO Hysteresis			100		mV
Enable/UVLO					
Enable Input Threshold		0.6	0.9	1.2	V
UVLO Threshold		1.4	1.5	1.6	V
Enable Input Current	$V_{EN/UVLO} = 5V$		0.2	5	μA
Current Limit					
Current Limit Threshold Voltage	(Voltage on CS to trip current limit)	90	110	130	mV
Error Amplifier					
Error Amplifier Gain			20		V/V
Current Amplifier					
Current Amplifier Gain			3.7		V/V
Oscillator Section					
Oscillator Frequency (f_O)		360	400	440	kHz
Maximum Duty Cycle	$V_{FB} = 1.0V$		85		%
Minimum On Time	$V_{FB} = 1.5V$		165		ns
Frequency Foldback Threshold	Measured on FB		0.3		V
Frequency Foldback Frequency			90		kHz

Parameter	Condition	Min	Typ	Max	Units
Gate Drivers					
Rise/Fall Time	$C_L = 3300\text{pF}$		25		ns
Output Driver Impedance	Source, $V_{IN} = 12\text{V}$		2	6	Ω
	Sink, $V_{IN} = 12\text{V}$		2	6	Ω
	Source, $V_{IN} = 5\text{V}$		3	7	Ω
	Sink, $V_{IN} = 5\text{V}$		3	7	Ω

Note 1. Absolute maximum ratings indicate limits beyond which damage to the component may occur. Electrical specifications do not apply when operating the device outside of its operating ratings. The maximum allowable power dissipation is a function of the maximum junction temperature, $T_{J(\text{Max})}$, the junction-to-ambient thermal resistance, θ_{JA} , and the ambient temperature, T_A .

Note 2. The device is not guaranteed to function outside its operating rating.

Note 3. Devices are ESD sensitive, handling precautions required. Human body model, $1.5\text{k}\Omega$ in series with 100pF .

Typical Characteristics

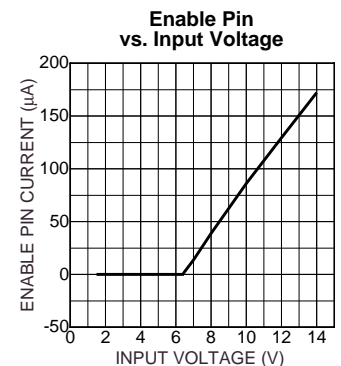
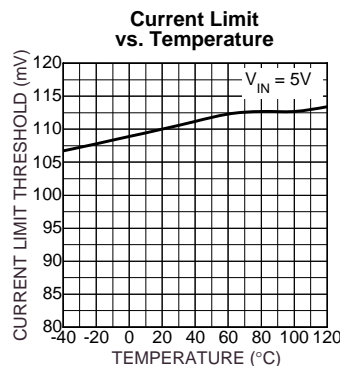
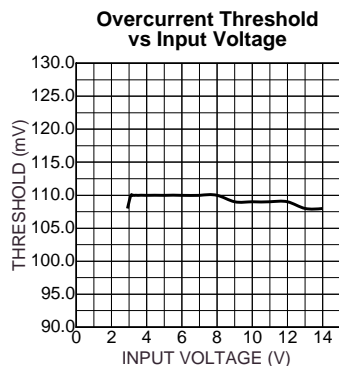
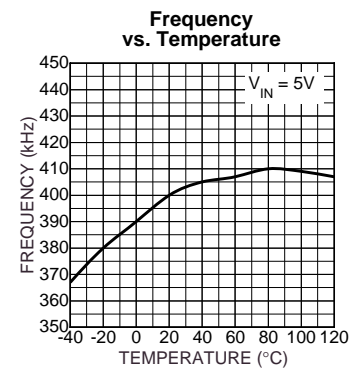
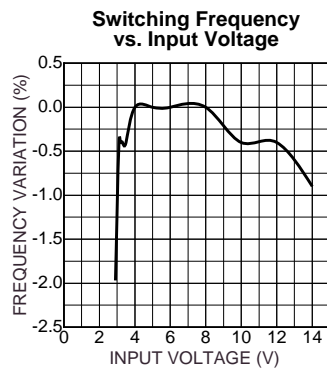
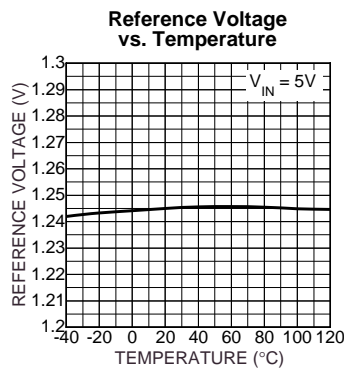
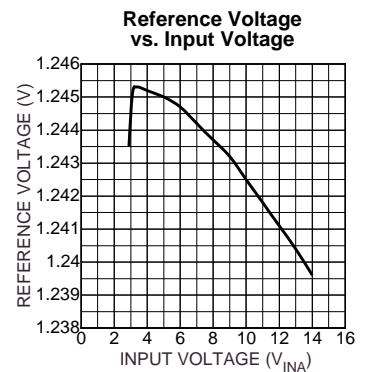
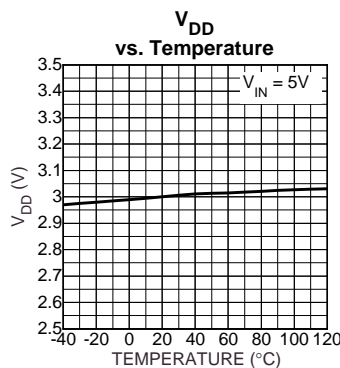
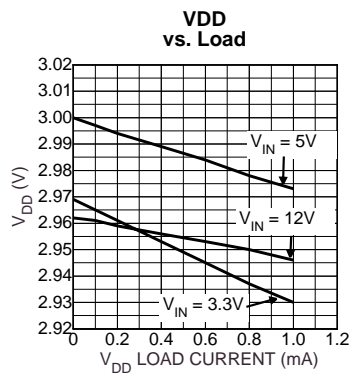
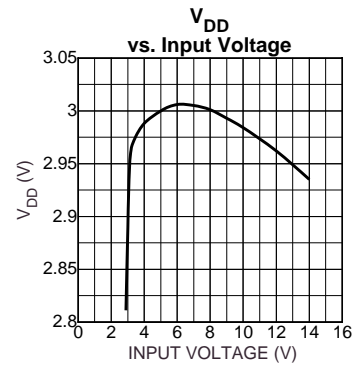
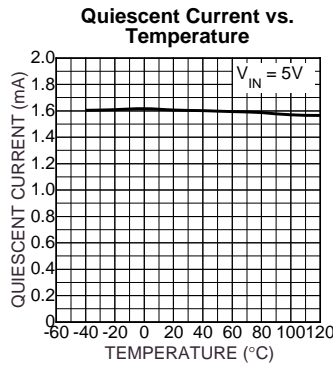
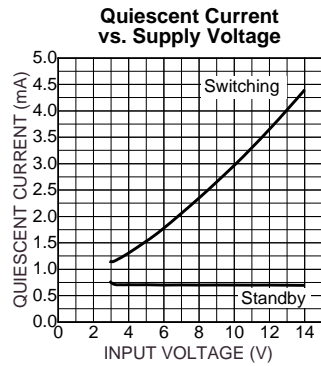

Functional Diagram

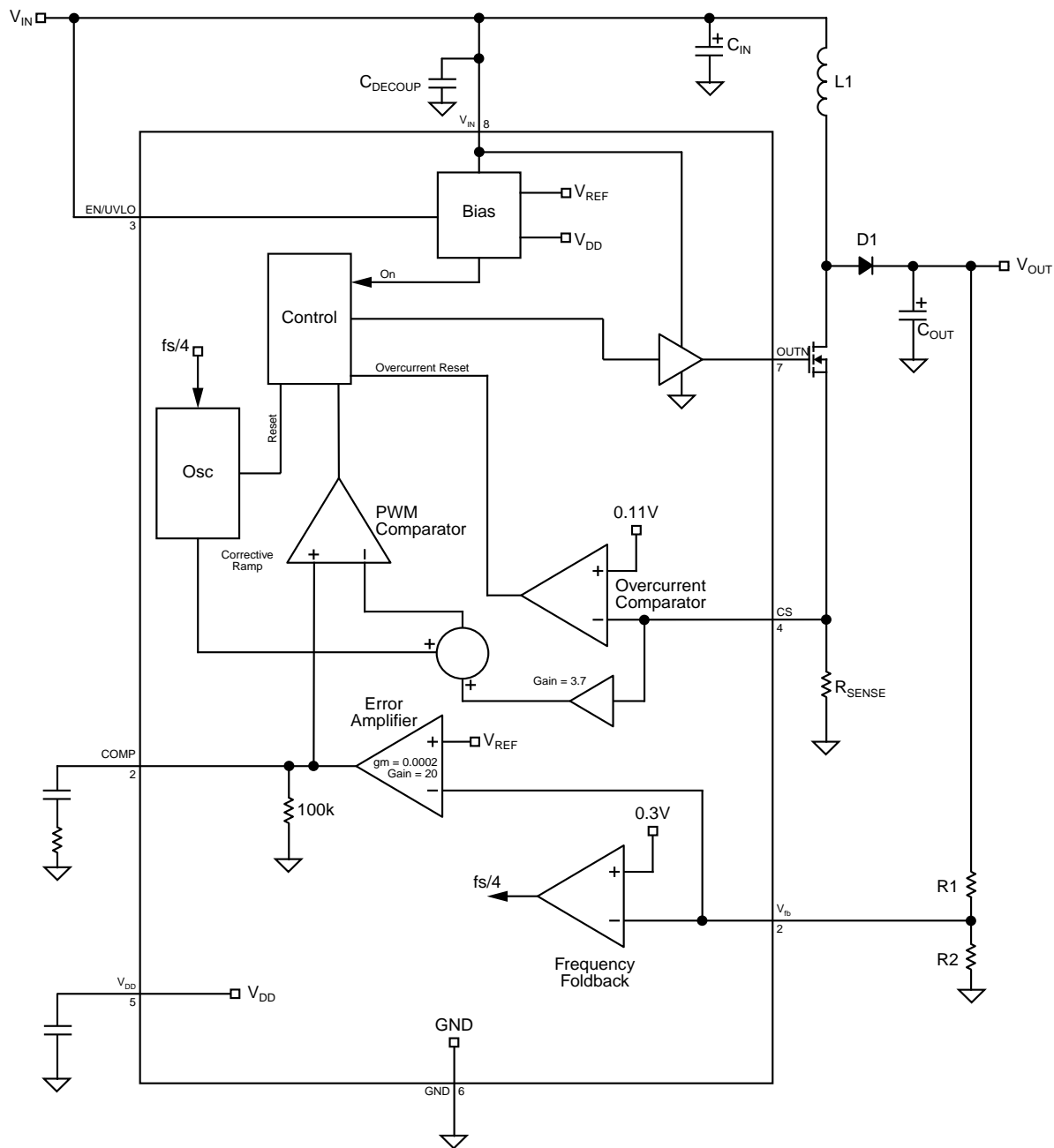

Figure 1. MIC2196 Block Diagram

Functional Description

The MIC2196 is a BiCMOS, switched-mode multi-topology controller. It will operate most low-side drive topologies including boost, SEPIC, flyback and forward. The controller has a low impedance driver capable of switching large N-channel MOSFETs. It features multiple frequency and duty cycle settings. Current mode control is used to achieve superior transient line and load regulation. An internal corrective ramp provides slope compensation for stable operation above a 50% duty cycle. The controller is optimized for high-efficiency, high-performance DC-DC converter applications. Figure 1 shows a block diagram of the MIC2196 configured as a PWM boost converter.

The switching cycle starts when OUTN goes high and turns on the low-side, N-channel MOSFET, Q1. The V_{GS} of the MOSFET is equal to V_{IN} . This forces current to ramp up in the inductor. The inductor current flows through the current sense resistor, R_{SENSE} . The voltage across the resistor is amplified and combined with an internal ramp for stability. This signal is compared with the error voltage signal from the error amplifier. When the current signal equals the error voltage signal, the low-side MOSFET is turned off. The inductor current then flows through the diode, D1, to the output. The MOSFET remains off until the beginning of the next switching cycle.

The description of the MIC2196 controller is broken down into several functions:

- Control Loop
 - PWM Operation
- Current Limit
- MOSFET gate drive
- Reference, enable & UVLO
- Oscillator

Control Loop

The MIC2196 operates in PWM (pulse-width modulated) mode.

PWM Operation

Figure 2 shows typical waveforms for PWM mode of operation. The gate drive signal turns on the external MOSFET which allows the inductor current to ramp up. When the MOSFET turns off, the inductor forces the MOSFET drain voltage to rise until the boost diode turns on and the voltage is clamped at approximately the output voltage.

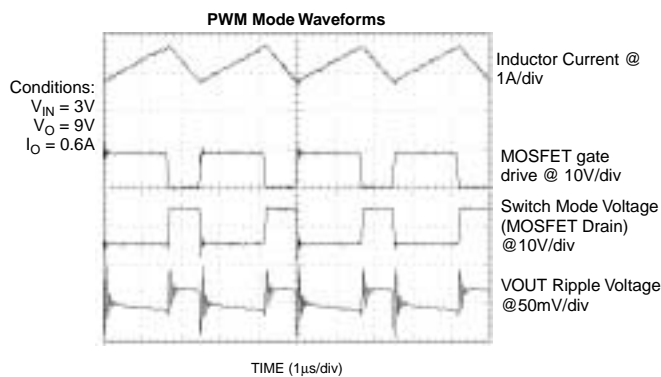

Figure 2. PWM Mode Waveforms

The MIC2196 uses current mode control to improve output regulation and simplify compensation of the control loop. Current mode control senses both the output voltage (outer loop) and the inductor current (inner loop). It uses the inductor current and output voltage to determine the duty cycle (D) of the buck converter. Sampling the inductor current effectively removes the inductor from the control loop, which simplifies compensation. A simplified current mode control diagram is shown in Figure 3.

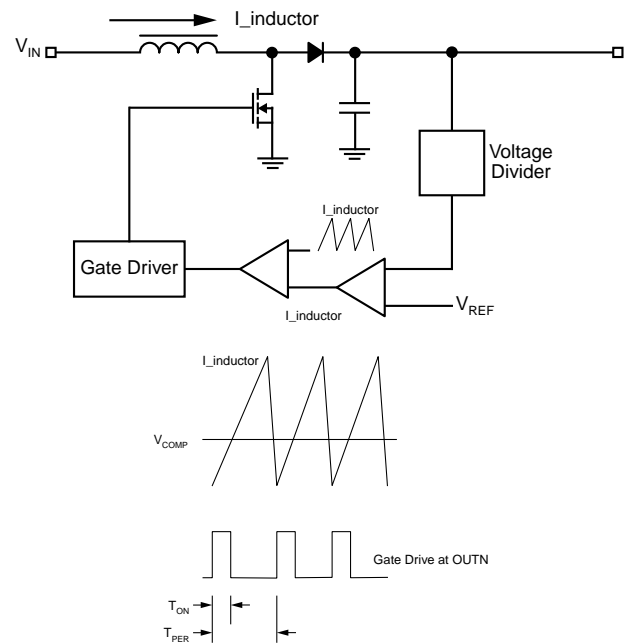

Figure 3: PWM Control Loop

A block diagram of the MIC2196 PWM current mode control loop is shown in Figure 1. The inductor current is sensed by measuring the voltage across a resistor, R_{SENSE} . The current sense amplifier buffers and amplifies this signal. A ramp is added to this signal to provide slope compensation, which is required in current mode control to prevent unstable operation at duty cycles greater than 50%.

A transconductance amplifier is used as an error amplifier, which compares an attenuated output voltage with a reference voltage. The output of the error amplifier is compared to the current sense waveform in the PWM block. When the current signal rises above the error voltage, the comparator turns off the low-side drive. The error signal is brought out to the COMP pin (pin 1) to provide access to the output of the error amplifier. This allows the use of external components to stabilize the voltage loop.

Current Sensing and Overcurrent Protection

The inductor current is sensed during the switch on time by a current sense resistor located between the source of the MOSFET and ground (R_{SENSE} in Figure 1). Exceeding the current limit threshold will immediately terminate the gate drive of the N-channel MOSFET, Q1. This forces the Q1 to operate at a reduced duty cycle, which lowers the output voltage. **In a boost converter, the overcurrent limit will not protect the power supply or load during a severe overcurrent condition or short circuit condition.** If the output is short-circuited to ground, current will flow from the input, through the inductor and output diode to ground. Only the impedance of the source and components limits the current.

The mode of operation (continuous or discontinuous), the minimum input voltage, maximum output power and the minimum value of the current limit threshold determine the value of the current sense resistor. Discontinuous mode is where all the energy in the inductor is delivered to the output at each switching cycle. Continuous mode of operation occurs when current always flows in the inductor, during both the low-side MOSFET on and off times. The equations below will help to determine the current sense resistor value for each operating mode.

The critical value of output current in a boost converter is calculated below. The operating mode is discontinuous if the output current is below this value and is continuous if above this value.

$$I_{\text{CRIT}} = \frac{V_{\text{IN}}^2 \times (V_{\text{O}} - V_{\text{IN}}) \times \eta}{2 \times f_{\text{S}} \times L \times V_{\text{O}}^2}$$

where:

η is the efficiency of the boost converter

V_{IN} is the minimum input voltage

L is the value of the boost inductor

f_{S} is the switching frequency

V_{O} is the output voltage

Maximum Peak Current in Discontinuous Mode:

The peak inductor current is:

$$I_{\text{IND(pk)}} = \sqrt{\frac{2 \times I_{\text{O}} \times (V_{\text{O}} - \eta \times V_{\text{IN}})}{L \times f_{\text{S}}}}$$

where:

I_{O} is the maximum output current

V_{O} is the output voltage

V_{IN} is the minimum input voltage

L is the value of the boost inductor

f_{S} is the switching frequency

η is the efficiency of the boost converter

The maximum value of current sense resistor is:

$$R_{\text{SENSE}} = \frac{V_{\text{SENSE}}}{I_{\text{IND(pk)}}}$$

where:

V is the minimum current sense threshold of the CS pin.

Maximum Peak Current in Continuous Mode:

The peak inductor current is equal to the average inductor current plus one half of the peak to peak inductor current.

The peak inductor current is:

$$I_{\text{IND(pk)}} = I_{\text{IND(ave)}} + \frac{1}{2} \times I_{\text{IND(pp)}}$$

$$I_{\text{IND(pk)}} = \frac{V_{\text{O}} \times I_{\text{O}}}{V_{\text{IN}} \times \eta} + \frac{V_{\text{L}} \times (V_{\text{O}} - V_{\text{IN}} \times \eta)}{2 \times V_{\text{O}} \times f_{\text{S}} \times L}$$

where:

I_{O} is the maximum output current

V_{O} is the output voltage

V_{IN} is the minimum input voltage

L is the value of the boost inductor

f_{S} is the switching frequency

η is the efficiency of the boost converter

V_{L} is the voltage across the inductor

V_{L} may be approximated as V_{IN} for higher input voltage. However, the voltage drop across the inductor winding resistance and low-side MOSFET on-resistance must be accounted for at the lower input voltages that the MIC2196 operates at:

$$V_{\text{L}} = V_{\text{IN}} - \frac{V_{\text{O}} \times I_{\text{O}}}{V_{\text{IN}} \times \eta} \times (R_{\text{WINDING}} + R_{\text{DSON}})$$

where:

R_{WINDING} is the winding resistance of the inductor

R_{DSON} is the on resistance of the low side switching MOSFET

The maximum value of current sense resistor is:

$$R_{\text{SENSE}} = \frac{V_{\text{SENSE}}}{I_{\text{IND(pk)}}}$$

where:

V_{SENSE} is the minimum current sense threshold of the CS pin.

The current sense pin, CS, is noise sensitive due to the low signal level. The current sense voltage measurement is referenced to the signal ground pin of the MIC2196. The current sense resistor ground should be located close to the IC ground. Make sure there are no high currents flowing in this trace. The PCB trace between the high side of the current sense resistor and the CS pin should also be short and routed close to the ground connection. The input to the internal current sense amplifier has a 30ns dead time at the beginning of each switching cycle. This dead time prevents leading edge current spikes from prematurely terminating the switching cycle. A small RC filter between the current sense pin and current sense resistor may help to attenuate larger switching spikes or high frequency switching noise. Adding the filter slows down the current sense signal, which has the effect of slightly raising the overcurrent limit threshold.

MOSFET Gate Drive

The MIC2196 converter drives a low-side N-channel MOSFET. The driver for the OUTN pin has a 2Ω typical source and sink impedance. The VIN pin is the supply pin for the gate drive circuit. The maximum supply voltage to the VIN pin is 14V.

MOSFET Selection

In a boost converter, the V_{DS} of the MOSFET is approximately equal to the output voltage. The maximum V_{DS} rating of the MOSFET must be high enough to allow for ringing and spikes in addition to the output voltage.

The VIN pin supplies the N-channel gate drive voltage. The V_{GS} threshold voltage of the N-channel MOSFET must be

low enough to operate at the minimum V_{IN} voltage to guarantee the boost converter will start up.

The maximum amount of MOSFET gate charge that can be driven is limited by the power dissipation in the MIC2196. The power dissipated by the gate drive circuitry is calculated below:

$$P_{\text{gate_drive}} = Q_{\text{gate}} \times V_{IN} \times f_S$$

where:

Q_{gate} is the total gate charge of the external MOSFET

The graph in Figure 4 shows the total gate charge which can be driven by the MIC2196 over the input voltage range. Higher gate charge will slow down the turn-on and turn-off times of the MOSFET, which increases switching losses.

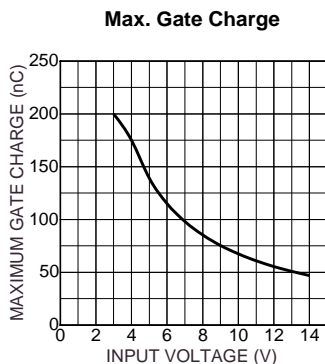

Figure 4. MIC2196 Frequency vs. Gate Charge

External Schottky Diode

In a boost converter topology, the boost diode, D1 must be rated to handle the peak and average current. The average current through the diode is equal to the average output current of the boost converter. The peak current is calculated in the current limit section of this specification.

For the MIC2196, Schottky diodes are recommended when they can be used. They have a lower forward voltage drop than ultra-fast rectifier diodes, which lowers power dissipation and improves efficiency. They also do not have a recovery time mechanism, which results in less ringing and noise when the diode turns off. If the output voltage of the circuit prevents the use of a Schottky diode, then only ultra-fast recovery diodes should be used. Slower diodes will dissipate more power in both the MOSFET and the diode. They will also cause excessive ringing and noise when the diode turns off.

Reference, Enable and UVLO Circuits

The output drivers are enabled when the following conditions are satisfied:

- The V_{DD} voltage (pin 5) is greater than its undervoltage threshold.
- The voltage on the enable pin is greater than the enable UVLO threshold.

The internal bias circuitry generates a 1.245V bandgap reference for the voltage error amplifier and a 3V V_{DD} voltage for the internal supply bus. The VDD pin must be decoupled to ground with a 1 μ F ceramic capacitor.

The enable pin (pin 3) has two threshold levels, allowing the MIC2196 to shut down in a micro-current mode, or turn-off output switching in standby mode. Below 0.9V, the device is forced into a micro power shutdown. If the enable pin is between 0.9V and 1.5V the output gate drive is disabled but the internal circuitry is powered on and the soft start pin voltage is forced low. There is typically 135mV of hysteresis below the 1.5V threshold to insure the part does not oscillate on and off due to ripple voltage on the input. Raising the enable voltage above the UVLO threshold of 1.5V enables the output drivers and allows the soft start capacitor to charge. The enable pin may be pulled up to V_{INA} .

Oscillator and Sync

The internal oscillator is self-contained and requires no external components. The maximum duty cycle of the MIC2196 is 85%.

Minimum duty cycle becomes important in a boost converter as the input voltage approaches the output voltage. At lower duty cycles, the input voltage can be closer to the output voltage without the output rising out of regulation. Minimum duty cycle is typically 7%.

A frequency foldback mode is enabled if the voltage on the feedback pin (pin 2) is less than 0.3V. In frequency foldback the oscillator frequency is reduced by approximately a factor of 4.

Voltage Setting Components

The MIC2196 requires two resistors to set the output voltage as shown in Figure 5.

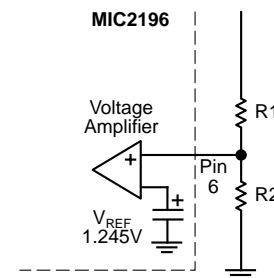

Figure 5. Voltage Setting Components

The output voltage is determined by the equation below.

$$V_O = V_{REF} \times \left(1 + \frac{R1}{R2}\right)$$

Where: V_{REF} for the MIC2196 is nominally 1.245V.

Lower values of resistance are preferred to prevent noise from appearing on the VFB pin. A typically recommended value for R1 is 10K.

Decoupling Capacitor Selection

A 1 μ F decoupling capacitor is used to stabilize the internal regulator and minimize noise on the VDD pin. Placement of this capacitor is critical to the proper operation of the MIC2196. It must be next to the VDD and signal ground pins and routed with wide etch. The capacitor should be a good quality ceramic. Incorrect placement of the VDD decoupling capacitor will cause jitter and/or oscillations in the switching waveform as well as variations in the overcurrent limit.

A minimum 1 μ F ceramic capacitor is required to decouple the V_{IN} . The capacitor should be placed near the IC and connected directly between pins 8 (VCC) and 6 (GND). For V_{IN} greater than 8V, use a 4.7 μ F or a 10 μ F ceramic capacitor to decouple the VDD pin.

Efficiency Calculation and Considerations

Efficiency is the ratio of output power to input power. The difference is dissipated as heat in the boost converter. The significant contributors at light output loads are:

- The V_{IN} pin supply current which includes the current required to switch the external MOSFETs.
- Core losses in the inductor.

To maximize efficiency at light loads:

- Use a low gate charge MOSFET or use the smallest MOSFET, which is still adequate for the maximum output current.
- Use a ferrite material for the inductor core, which has less core loss than an MPP or iron power core.

The significant contributors to power loss at higher output loads are (in approximate order of magnitude):

- Resistive on-time losses in the MOSFET
- Switching transition losses in the MOSFET
- Inductor resistive losses

- Current sense resistor losses
- Output capacitor resistive losses (due to the capacitor's ESR)

To minimize power loss under heavy loads:

- Use logic level, low on resistance MOSFETs. Multiplying the gate charge by the on-resistance gives a figure of merit, providing a good balance between switching and resistive power dissipation.
- Slow transition times and oscillations on the voltage and current waveforms dissipate more power during the turn-on and turn-off of the low side MOSFET. A clean layout will minimize parasitic inductance and capacitance in the gate drive and high current paths. This will allow the fastest transition times and waveforms without oscillations. Low gate charge MOSFETs will switch faster than those with higher gate charge specifications.
- For the same size inductor, a lower value will have fewer turns and therefore, lower winding resistance. However, using too small of a value will increase the inductor current and therefore require more output capacitors to filter the output ripple.
- Lowering the current sense resistor value will decrease the power dissipated in the resistor. However, it will also increase the overcurrent limit and may require larger MOSFETs and inductor components to handle the higher currents.
- Use low ESR output capacitors to minimize the power dissipated in the capacitor's ESR.

Package Information

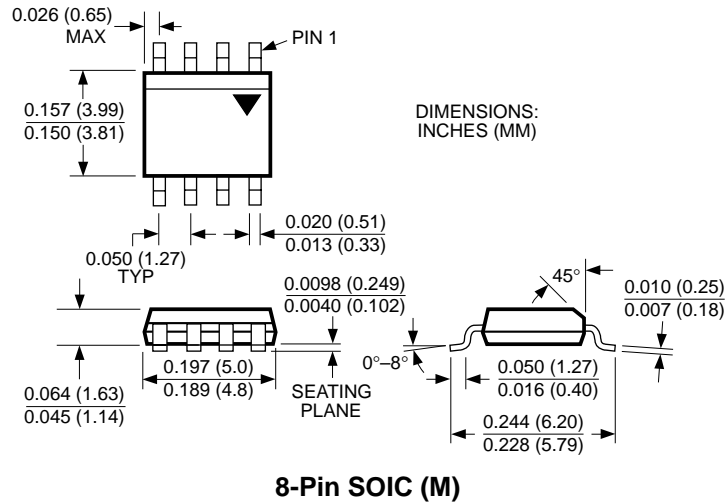

MICREL INC. 1849 FORTUNE DRIVE SAN JOSE, CA 95131 USA

TEL + 1 (408) 944-0800 FAX + 1 (408) 474-1000 WEB <http://www.micrel.com>

This information is believed to be accurate and reliable, however no responsibility is assumed by Micrel for its use nor for any infringement of patents or other rights of third parties resulting from its use. No license is granted by implication or otherwise under any patent or patent right of Micrel Inc.

© 2004 Micrel Incorporated