

SANYO	No. ✕4872	LC74401E, 74402, 74402E
		PIP Controllers

Preliminary

Overview

The LC74401E, LC74402, and LC74402E are memory controllers for TV set and VCR PIP (picture in picture) systems. Since these LSIs include three D/A converter circuits, a component PIP system can be constructed by combining one of these LSIs with memory and an A/D converter such as the LC7480.

Features

- Horizontal resolution: 600 TV lines*1
- Three D/A converters (for the Y, R-Y, and B-Y signals) are incorporated in the PIP memory controller block.
- High image quality is supported by vertical filter function frame memory processing*2.
- I²C bus controlled.
- Built-in PLL circuit (requires an external LPF)
- Supports NTSC, PAL, and multiple (NTSC-PAL) formats
- External control functions (only provided by the LC74401E)
 - 8-bit D/A converter (PWM): Six pins
 - General-purpose ports: Four pins
- Sub-screen specifications
 - Number of sub-screens: 1-8*2
 - Display on/off and frame on/off/color switching, wipe function
 - Supports switching between fixed (4 corners) and arbitrary (8-bit specification of vertical and horizontal position) display positions.
 - Size: Area: 1/4, 1/9, 1/16, Vertical compression: 1/2, 1/3, 1/4; Horizontal compression: 2/3, 1/3, 1/6
- Note: Horizontal compression can be adjusted by changing the PLL divisor.
The display area can be changed independently in the vertical and horizontal directions.
- Horizontal resolution (Y signal): About 250 dots
- Gradation (quantization): 64 (6 bits)
- Operating supply voltage: 5 V ± 10%

- QIP80E: LC74401E
- DIP64S: LC74402-Pin assignment identical to the LC7442 (except for the serial control pins)
- QIP64E: LC74402E-Pin assignment identical to the LC7442E (except for the serial control pins)

Note 1

	D/A Clock
Y	15.00 MHz
R-Y	3.75 MHz
B-Y	3.75 MHz

When the main screen synchronization PLL has the standard value (PLL7 to PLL3 = 10011)

Note 2: The specifications depend on the amount of external memory as listed in the table below.

Display memory	256 K	1 M
One screen	△	○
Two screens	X	○
Three screens	X	△
Four screens	X	△

- : Frame display of both dynamic and static images supported. (Frame memory processing)
- △: Frame display of dynamic images only supported.
- X: Not supported.
- Note: The number of sub-screens listed in the table above are doubled in split mode. (However, image quality is reduced.)

Package Dimensions

unit: mm

3174-QIP80E

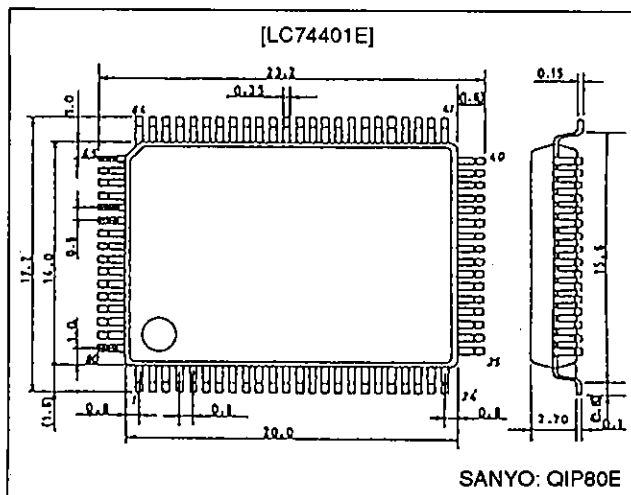

LC74401E, 74402, 74402E

unit: mm
3071-DIP64S

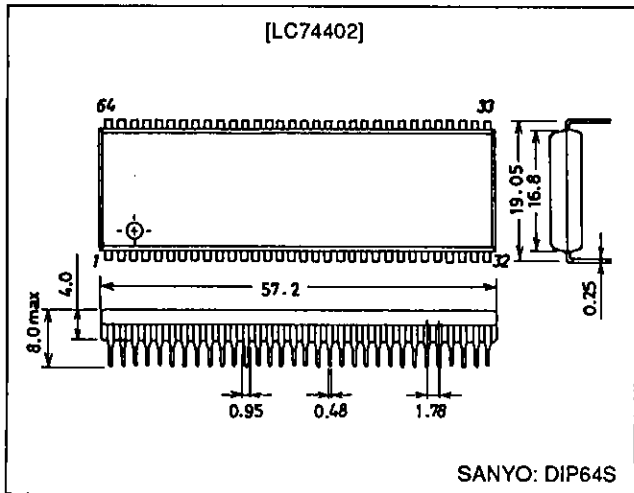

unit: mm
3159-QIP64E

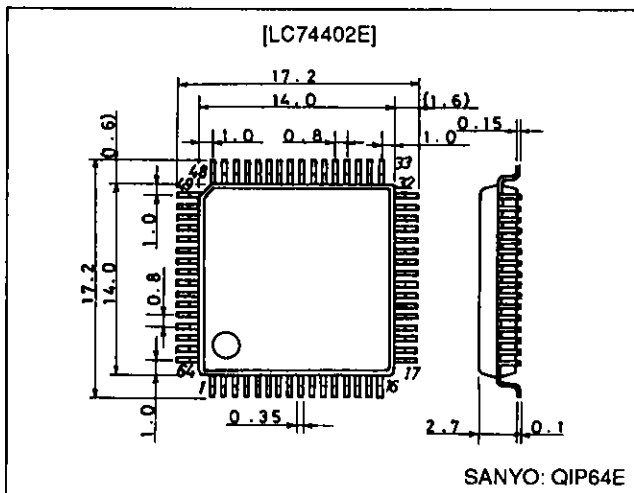

Pin Assignments (Top View)

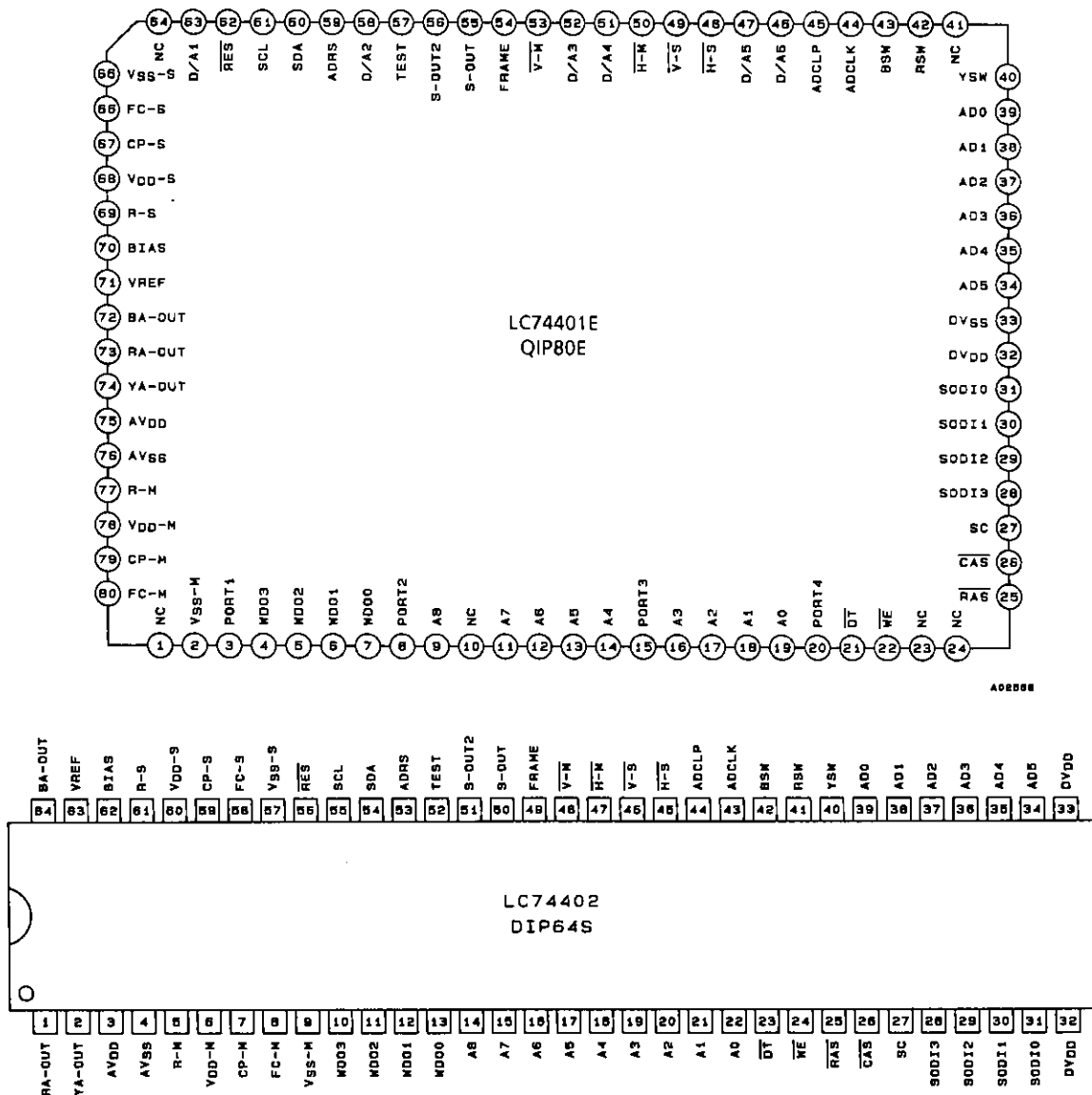

LC74401E, 74402, 74402E

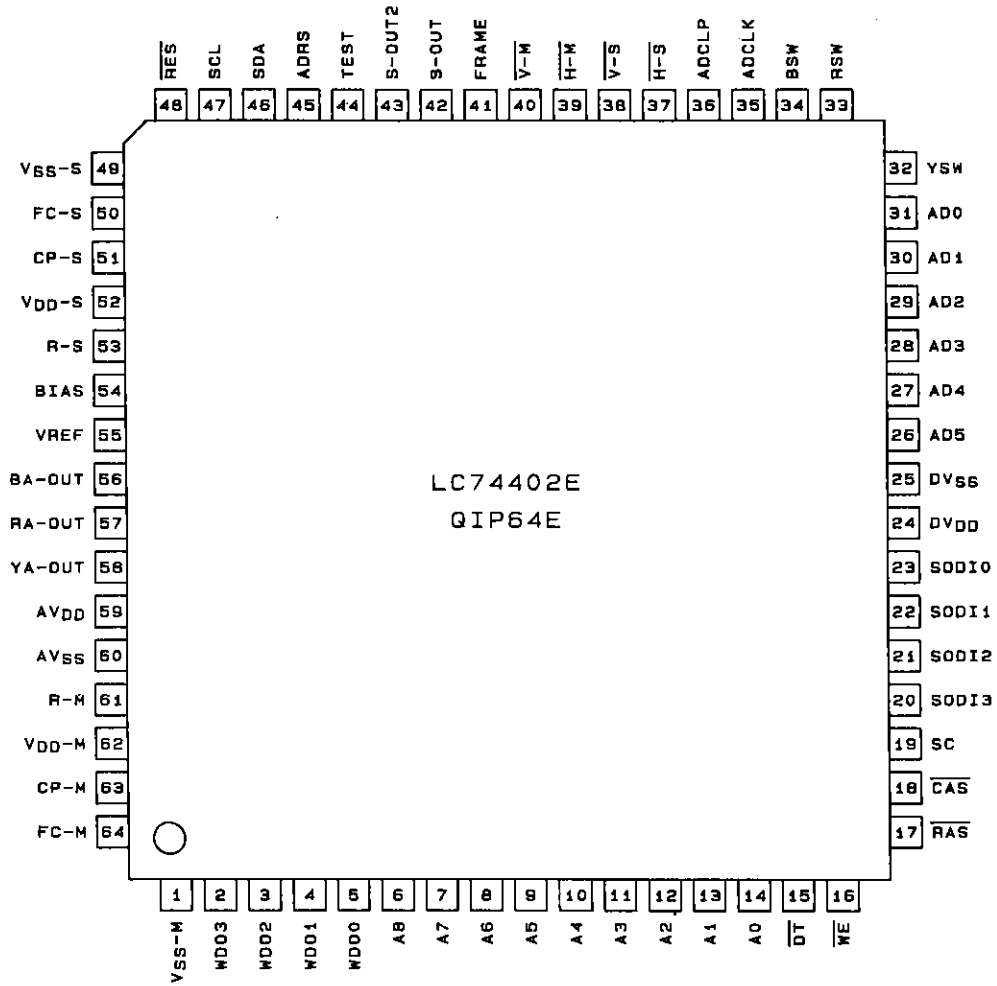

A09724

Component-Type PIP System Structure Based on the LC74401E/2/2E and the LC7480

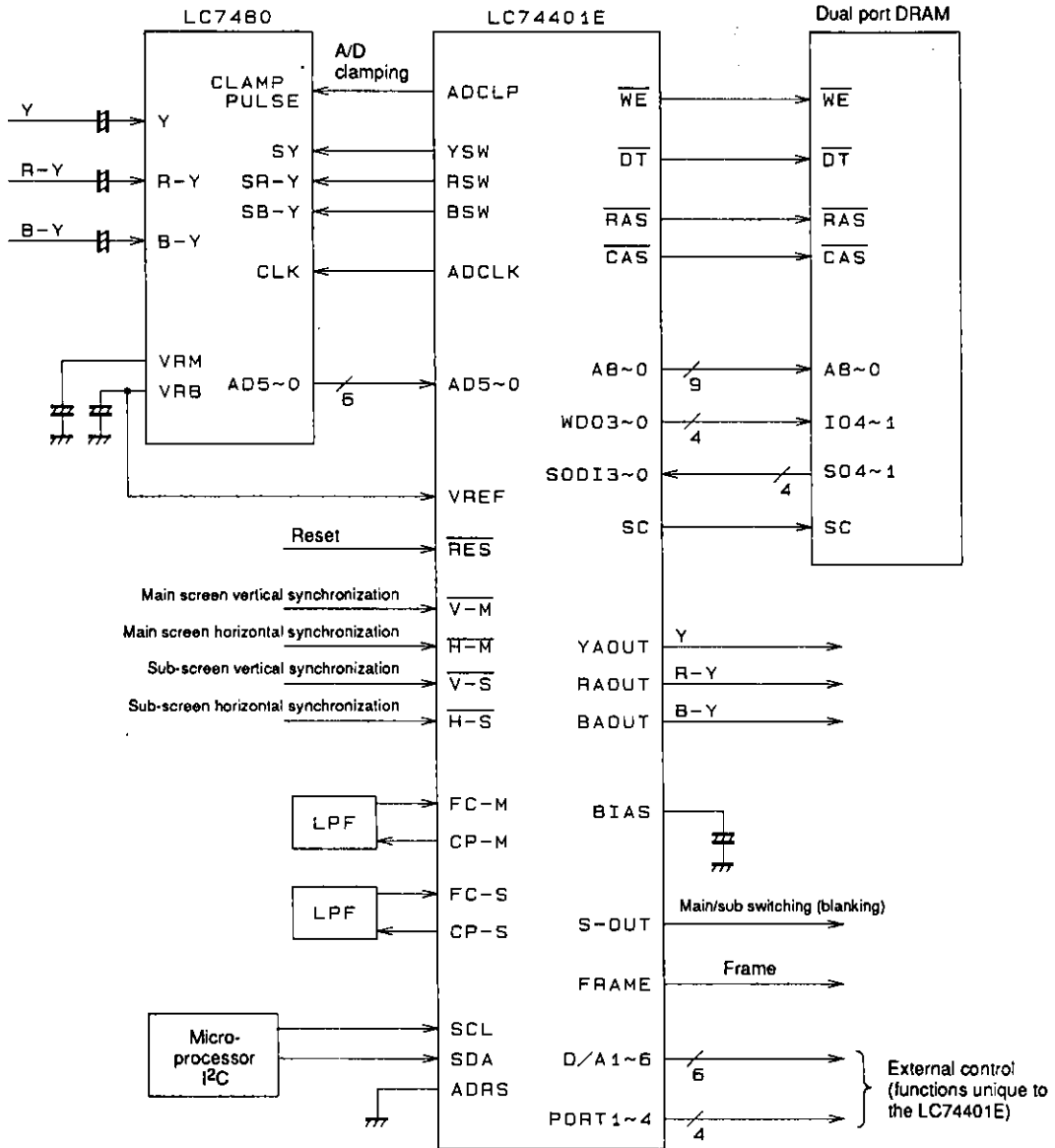

A02570

Functional Overview

1. Reduction options

Vertical: Selectable 1/2, 1/3 and 1/4 reduction vertical filter coefficients.

Horizontal: (1/1) to 2/3 to (1/2) to 1/3 to (1/4) to 1/6. Intermediate values are implemented using the aspect correction function.

2. Number of sub-screens

With 1 Mb of memory: 1 to 4 or (8). * Values in parentheses are for SPLIT mode, where the image quality is reduced.

With 256 kb of memory: 1 or (2).

3. Static images

With 1 Mb of memory: Frame static image (supported with 2 or fewer screens) or field static images

With 256 kb of memory: Field static image

4. Display position

Screen A: Fixed positions in the four corners

Screen B: Free positioning (Specified by 8 bits in each of the vertical and horizontal directions.)

5. Frame

- On/off selectable

- Two types that differ by insertion method

— Pin frame: The frame position is specified by a high level pin output. (application frame insertion)

— D/A frame: A 50% white or arbitrary color overlapped on the Y, R-Y, and B-Y video signals.

6. Wipe

Twelve types

7. Blanking size

The vertical and horizontal directions can be specified independently (6 bits each)

Sixteen forms can be specified.

8. Blue background

The sub-screen can be set to all blue or all black.

9. Memory clear

Sets the data written to video memory to a fixed value corresponding to a 25% white color.

10. Wide-screen TV support

- Aspect correction function

- Subtitle shifting

The subtitle area can be trimmed and displayed as a sub-screen.

The vertical reduction ratio can be set independently to 1/4, 1/3, or 1/2. The horizontal reduction can be set to values up to 1/1 using mode 2E.

11. Support for NTSC, PAL, and multi-mode (NTSC-PAL) products

12. External control functions using an I²C interface (LC74401E only)

- Six 8-bit D/A converter circuits built-in (PWM)

- Four general-purpose ports built-in

13. Setting adjustments

Fine adjustment of various settings, including sub-screen position displacement and color shift is supported.

Sub-screen Size

The vertical and horizontal directions are controlled independently.

1. Vertical size

- 1/3 to (3) scan lines are compressed to a single scan line
- 1/4 to (4) scan lines are compressed to a single scan line

2. Horizontal size

- 1/3 to A/D clock: D/A clock = 1:3
- 1/6 to A/D clock: D/A clock = 1:6

The data required for 1/6 reduction is one half that for 1/3 reduction.

• Aspect correction function

The horizontal direction size is adjusted by changing the VCO oscillator frequency (system clock).

This can be adjusted from -30% to +30%.

However, care is required when using this function. See the Application Manual for details.

• 2E mode

If 2E mode is used when 1/3 size is selected, the horizontal direction is expanded by a factor of two. This is normally used only for special functions such as split mode.

Number of Sub-screens

Between one and eight sub-screens can be specified (when 1 Mb of VRAM is used).

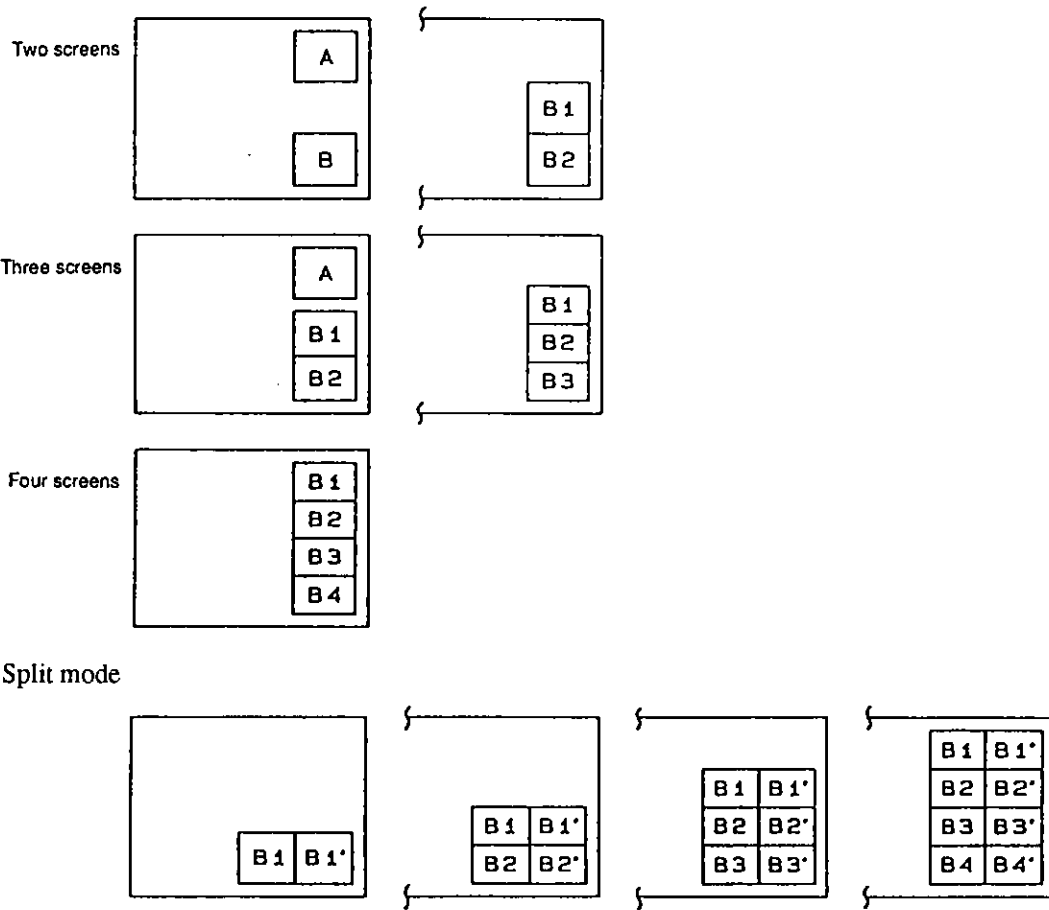

A02071

Refer to the Application Manual for details on using these modes.

Wipe Function

Wipe operation can be set in the top, bottom, left, and right directions, and in the diagonal direction independently.

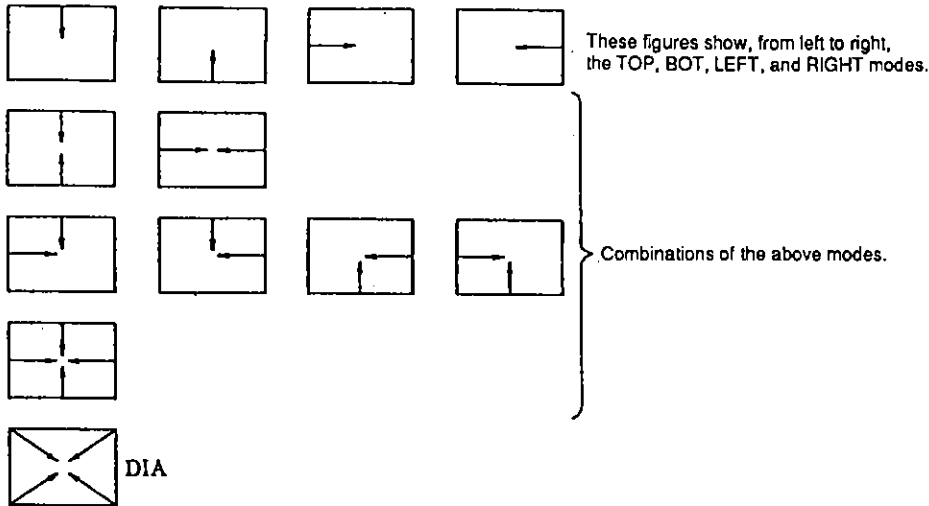

A02572

After a wipe mode has been set up, it operates automatically each time a sub-screen is switched on or off.

Display Area Function

This function controls the blanking area.

The vertical direction and horizontal direction can be set up independently.

The operating mode is set by setting the wipe function TOP, BOT, LEFT, or RIGHT mode.

Application Example

1. Excluding the masked portion of the letter box screen

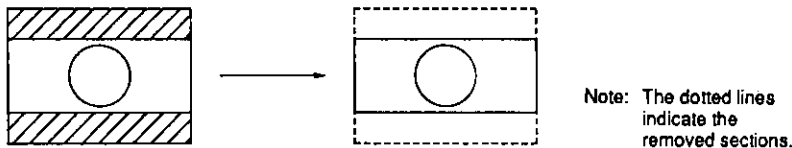

A02573

2. Subtitle display

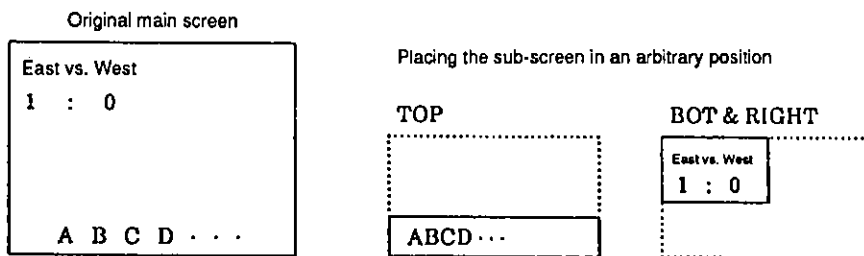

3. Small display

Reduces the portion of the main screen that is hidden.

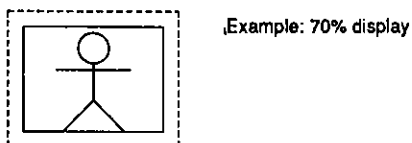

A02574

Multi-Mode

1. When 1 Mb of VRAM is used

- Frame memory processing (FRM = high)
 - Dynamic images: Frame display (MUL = high, overrun phenomenon occurs)
 - Static images: Frame display
- Field memory processing (FRM = low, FILD = high)
 - Dynamic images: Field display (overrun phenomenon occurs)
 - Static images: Field display

NTSC/PAL (= main/sub)

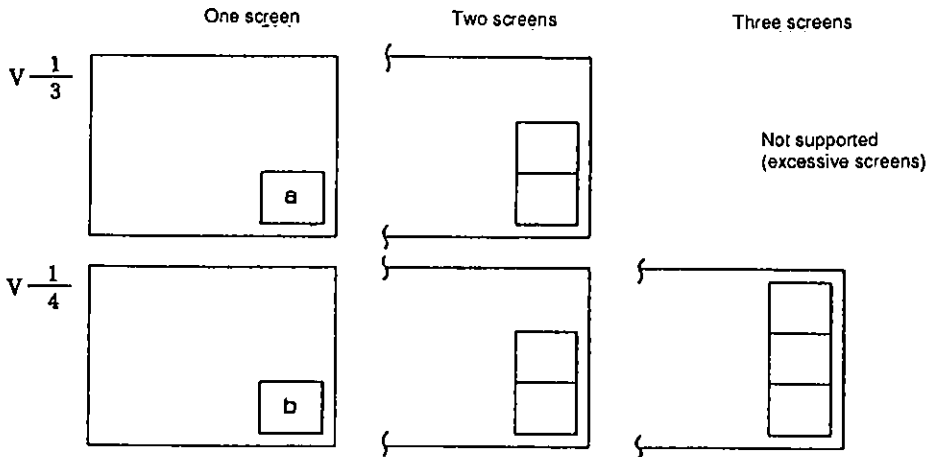

PAL/NTSC

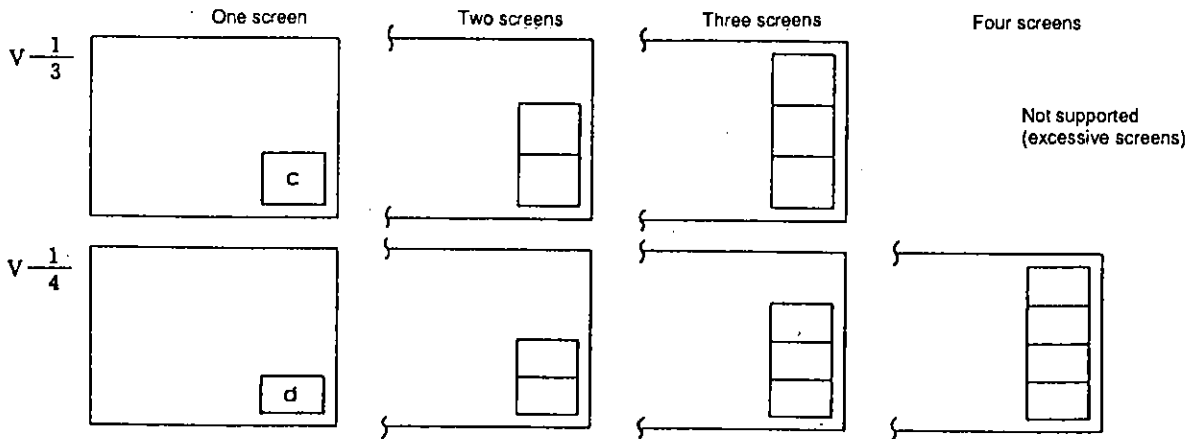

The sub-screen size ratio (V) will be:

$$a : b : c : d = 1 : 0.8 : 0.77 : 0.58$$

If b and c are used, the size change can be held to 5%.

2. When 256 kb of VRAM are used

- Field memory processing (FRM = low, FILD = high)
 - Dynamic images: Field display (overrun phenomenon occurs)
 - Static images: Field display
- Only one screen can be displayed.

Control Register Table

Address (HEX)	MSB 7	6	5	4	3	2	1	LSB 0	
01	SBY	STL	NT/PAL	MUL	FILD	FRM	P-NUM1	P-NUM0	Operating mode 1
02	WRT2	WRT1	WRT0	D-FIX	POUT-B	POUT-A	FVP	FHP	Operating mode 2
03	VP7	VP6	VP5	VP4	VP3	VP2	VP1	VP0	Screen B display position (V)
04	HP7	HP6	HP5	HP4	HP3	HP2	HP1	HP0	Screen B display position (H)
05	FRM-B	FRM-A	FRC-B	FRC-A	YFC5	YFC4	YFC3	YFC2	Frame setting, frame color (Y)
06	RFC5	RFC4	RFC3	RFC2	BFC5	BFC4	BFC3	BFC2	Frame color (R-Y, B-Y)
07	VDF-CO	HDF. 2E	CL-AJ1	CL-AJ0	FM-AJ1	FM-AJ0	YC-AJ1	YC-AJ0	Filter setting, adjustment 1
08	SIZE-V	SIZE-H	SPLIT	PLL7	PLL6	PLL5	PLL4	PLL3	Sub-screen size, PLL
09	WPE-B	WPE-A	TOP	BOT	LEFT	RIGHT	DIA	WP-MOD	Wipe setting
0A	PHP-M	PHP-S	VBS5	VBS4	VBS3	VBS2	VBS1	VBS0	Display area (V)
0B	DT-AJ1	DT-AJ0	HBS5	HBS4	HBS3	HBS2	HBS1	HBS0	Display area (H)
0C	TEXT	UPPER	M-BLUE	M-LVL	YL5	YL4	YL3	YL2	Subtitle display setting
0D	WV-AJ1	WV-AJ0	WH-AJ1	WH-AJ0	VP-AJ1	VP-AJ0	HP-AJ1	HP-AJ0	Display adjustment 2
0E	DAC1-7	DAC1-6	DAC1-5	DAC1-4	DAC1-3	DAC1-2	DAC1-1	DAC1-0	8-bit D/A converter 1 data
0F	DAC2-7	DAC2-6	DAC2-5	DAC2-4	DAC2-3	DAC2-2	DAC2-1	DAC2-0	8-bit D/A converter 2 data
10	DAC3-7	DAC3-6	DAC3-5	DAC3-4	DAC3-3	DAC3-2	DAC3-1	DAC3-0	8-bit D/A converter 3 data
11	DAC4-7	DAC4-6	DAC4-5	DAC4-4	DAC4-3	DAC4-2	DAC4-1	DAC4-0	8-bit D/A converter 4 data
12	DAC5-7	DAC5-6	DAC5-5	DAC5-4	DAC5-3	DAC5-2	DAC5-1	DAC5-0	8-bit D/A converter 5 data
13	DAC6-7	DAC6-6	DAC6-5	DAC6-4	DAC6-3	DAC6-2	DAC6-1	DAC6-0	8-bit D/A converter 6 data
14	0	0	0	0	PORT-4	PORT-3	PORT-2	PORT-1	General-purpose port
15	V-1/2	0	0	0	0	0	0	0	Test data

Note: 1. "0" indicates that the register value is set to 0.

2. When designing an application, be sure to read the Application Manual and check any relevant notes.

3. Addresses 0E to 14 are only valid for the LC74401E.

Register Data Overview

Address	Symbol	Description
01	SBY	Standby mode (PLL circuit operating)
	STL	Static image (All writing stopped)
	NT/PAL	Format selection (high: NTSC, low: PAL)
	MUL	Multi-mode
	FILD	Field display selection
	FRM	Frame memory processing selection
	P-NUM1, 0	Number of screen B screens displayed (one to four screens)
02	WRT2 to 0	Dynamic image setting (write screen specification)
	D-FIX	Memory clear (fixes the memory write data)
	POUT-B, A	Sub-screen display on/off
	FVP, FHP	Four corner fixed position (screen A) specification
03	VP7 to 0	Screen B vertical position data
04	HP7 to 0	Screen B horizontal position data
05	FRM-B, A	D/A converter frame on/off
	FRC-B, A	D/A converter frame color register value specification
	YFC5 to 2	D/A converter frame color (Y)
06	RFC5 to 2	D/A converter frame color (R-Y)
	BFC5 to 2	D/A converter frame color (B-Y)
07	VDF-CO	Vertical filter coefficient specification
	HDF, 2E	HDF (horizontal filter on/off when SIZE-H = 1)
		2E mode (horizontal 2x expansion) on/off when SIZE-H = 0
	CL-AJ1, 0	A/D converter clamping position adjustment
	FM-AJ1, 0	D/A converter frame left/right thickness adjustment
YC-AJ1, 0	Position adjustment for C (R-Y, B-Y) with respect to Y	
08	SIZE-V	Vertical reduction specification H: 1/4 L: 1/3
	SIZE-H	Horizontal reduction specification H: 1/6 L: 1/3
	SPLIT	Split mode (Doubles the number of screens by splitting the sub-screens horizontally.)
	PLL7 to 3	PLL divisor value (10011 is the standard value)
09	WPE-B, A	Wipe or display area function enable
	TOP to DIA	Wipe or display area function shape specification
	WP-MOD	Wipe or display area function selection (high: wipe)
0A	PHP-M, S	Inversion or non-inversion of the field determination result
	VBS5 to 0	Display area value setting (vertical direction)
0B	DT-AJ1, 0	Memory control signal (\overline{DT}) adjustment
	HBS5 to 0	Display area value setting (horizontal direction)
0C	TEXT	Partial display of an image reduced 1/2 in the vertical direction
	UPPER	Section specification for partial display in TEXT mode
	M-BLUE	Blue specification in masking mode
	M-LVL	Y level specification for the masked section
	YL-5 to 2	Masking level (data compared to the Y level)
0D	WV-AJ1, 0	Write vertical direction adjustment
	WH-AJ1, 0	Write horizontal direction adjustment
	VP-AJ1, 0	Display position vertical direction adjustment
	HP-AJ1, 0	Display position horizontal direction adjustment
0E	DAC1-7 to 0	External control D/A converter (8-bit PWM) data
0F	DAC2-7 to 0	
10	DAC3-7 to 0	
11	DAC4-7 to 0	
12	DAC5-7 to 0	
13	DAC6-7 to 0	
14	PORT-4 to 1	General-purpose port data
15	V-1/2	Vertical reduction specification 1/2

Note: The register functions at register addresses 0E to 14 can only be used with the LC74401E.

LC74401E, 74402, 74402E

Pin Functions

Pin No. 80E: LC74401E, 64S: LC74402, 64E: LC74402E

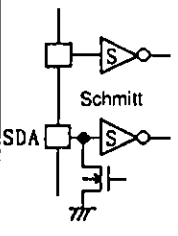
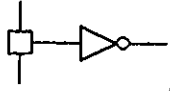
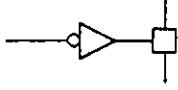
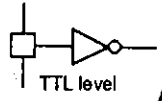
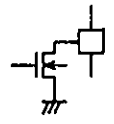
Pin No.			Symbol	I/O	Connection	Functions		Circuit type
64S	64E	80E						
48	40	53	$\overline{V-M}$	I	LA7403 or a sync separator IC	Main screen vertical synchronization signal (negative polarity)		
47	39	50	$\overline{H-M}$	I		Main screen horizontal synchronization signal (negative polarity)		
46	38	49	$\overline{V-S}$	I		Sub-screen vertical synchronization signal (negative polarity)		
45	37	48	$\overline{H-S}$	I		Sub-screen horizontal synchronization signal (negative polarity)		
55	47	61	SCL	I	Microprocessor	Serial clock	I ² C	A02576
54	46	60	SDA	I/O		Serial data		
53	45	59	ADRS	I	V _{SS}			
56	48	62	\overline{RES}	I	Initialization circuit	Reset		
52	44	57	TEST	I	V _{SS}	Test (Tied to V _{SS} in normal operation.)		A02577
—	—	3	PORT1	O		General-purpose ports		
—	—	8	PORT2	O				
—	—	15	PORT3	O				
—	—	20	PORT4	O				
10	2	4	WDO3	O	Memory	Memory write data outputs		
11	3	5	WDO2	O				
12	4	6	WDO1	O				
13	5	7	WDO0	O				
14	6	9	A8	O	Memory	MSB	Address (A8 is left open when a 256 kbyte external memory is used.)	
15	7	11	A7	O				
16	8	12	A6	O				
17	9	13	A5	O				
18	10	14	A4	O				
19	11	16	A3	O				
20	12	17	A2	O				
21	13	18	A1	O				
22	14	19	A0	O		LSB		
23	15	21	\overline{DT}	O	Memory	Control signals		A02578
24	16	22	\overline{WE}	O				
25	17	25	\overline{RAS}	O				
26	18	26	\overline{CAS}	O				
27	19	27	SC	O				
28	20	28	SODI3	I	Memory	Memory read data inputs		
29	21	29	SODI2	I				
30	22	30	SODI1	I				
31	23	31	SODI0	I				
—	—	63	D/A1	O		PWM D/A converter output		
—	—	58	D/A2	O				
—	—	52	D/A3	O				
—	—	51	D/A4	O				
—	—	47	D/A5	O				
—	—	46	D/A6	O				

Continued on next page.

LC74401E, 74402, 74402E

Continued from preceding page.

Pin No. 80E: LC74401E, 64S: LC74402, 64E: LC74402E

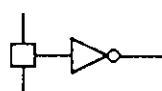
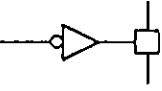
Pin No.			Symbol	I/O	Connection	Functions		Circuit type	
64S	64E	80E							
34	26	34	AD5	I	LC7480	MSB	Inputs for A/D converted digital data		
35	27	35	AD4	I					
36	28	36	AD3	I					
37	29	37	AD2	I					
38	30	38	AD1	I					
39	31	39	AD0	I					
40	32	40	YSW	O	LC7480	Y signal selection	MPX switching signals		
41	33	42	RSW	O					R-Y signal selection
42	34	43	BSW	O					B-Y signal selection
43	35	44	ADCLK	O	LC7480	Sampling clock		A02578	
44	36	45	ADCLP	O	LC7480	Clamping pulse			
49	41	54	FRAME	O	LA7403	Frame pulse output			
50	42	55	S-OUT	O	LA7403	Main/sub switching signal			
51	43	56	S-OUT2	O	—	Control signal			
32	24	32	DV _{DD}			Digital power supply (for logic circuits and line memory)			
33	25	33	DV _{SS}						
2	58	74	YA-OUT	O	LA7403	Y signal	D/A converter outputs		
1	57	73	RA-OUT	O					R-Y signal
64	56	72	BA-OUT	O					B-Y signal
63	55	71	VREF	I	LC7480	D/A converter analog system settings			
62	54	70	BIAS	—	Capacitor				
3	59	75	AV _{DD}			D/A converter analog system power supply			
4	60	76	AV _{SS}						
7	63	79	CP-M	O	LPF	Charge pump output	Main screen synchronization VCO		
8	64	80	FC-M	I	LPF	Oscillator control voltage input			
5	61	77	R-M	—	Resistor	Oscillator range resistor			
6	62	78	V _{DD} -M			Power supply			
9	1	2	V _{SS} -M						
59	51	67	CP-S	O	LPF	Charge pump output	Main screen synchronization VCO		
58	50	66	FC-S	I	LPF	Oscillator control voltage input			
61	53	69	R-S	—	Resistor	Oscillator range resistor			
60	52	68	V _{DD} -S			Power supply			
57	49	65	V _{SS} -S						

Specifications

Absolute Maximum Ratings at Ta = 25 ± 8°C, V_{SS} = 0 V

Parameter	Symbol	Conditions	Ratings	Unit
Maximum supply voltage	V _{DD} max		-0.3 to +7.0	V
Input voltage	V _{IN}		-0.3 to V _{DD} + 0.3	V
Output voltage	V _{OUT}		-0.3 to V _{DD} + 0.3	V
Allowable power dissipation	Pd max		350	mW
Operating temperature	T _{opr}		-10 to +70	°C
Storage temperature	T _{stg}		-55 to +125	°C

LC74401E, 74402, 74402E

Allowable Operating Ranges at $T_a = -10$ to $+70^\circ\text{C}$, $V_{SS} = 0\text{ V}$

Parameter	Symbol	Conditions	min	typ	max	Unit
Supply voltage	V_{DD}		4.5	5.0	5.5	V
Input high level voltage	V_{IH1}	CMOS level	$0.7 V_{DD}$			V
	V_{IH2}	TTL level	2.2			V
Input low level voltage	V_{IL1}	CMOS level			$0.3 V_{DD}$	V
	V_{IL2}	TTL level			0.8	V
Reference voltage	V_{REF}		3.4	$0.8 V_{DD}$	V_{DD}	V

Electrical Characteristics at $T_a = 25 \pm 2^\circ\text{C}$, $V_{DD} = 5\text{ V} \pm 10\%$, $V_{SS} = 0\text{ V}$

Parameter	Symbol	Conditions	min	typ	max	Unit
Output high level voltage	V_{OH1}	Pins CP-M and CP-S: $I_{OH} = -1\text{ mA}$	$V_{DD} - 1$			V
	V_{OH2}	Pins other than CP-M and CP-S: $I_{OH} = -1\text{ mA}$	$V_{DD} - 1$			V
Output low level voltage	V_{OL1}	Pins CP-M and CP-S: $I_{OL} = 1\text{ mA}$			1.0	V
	V_{OL2}	Pins other than CP-M and CP-S: $I_{OL} = 2\text{ mA}$			0.4	V
	V_{OL3}	With the SDA pin output active: $I_{OL} = 3\text{ mA}$			0.4	V
Operating current drain*1	I_{DDD}	The DV_{SS} pin		25		mA
	I_{DDA}	The AV_{SS} pin		21		mA
	I_{DDM}	The V_{SS-M} pin		2		mA
	I_{DDS}	The V_{SS-S} pin		2		mA
Quiescent current	I_{DDs}	RES: V_{SS} with DC signals on the input pins and no output load.			10	μA
Input leakage current	I_{LK}	$V_I = V_{DD}, V_{SS}$	-1		+1	μA
Output leakage current	I_{OZ}	Pins CP-M and CP-S; $V_I = V_{DD}, V_{SS}$	-1		+1	μA
D/A converter output resistance	R_{DA}			150		Ω

Note: 1. Test conditions as follows:

RES: V_{DD} , $V-M$, $V-S$: 60 Hz, H-M, H-S: 15 kHz

A/D converter data: 1010..., No output load

2. There are four power supply pin systems.

The supply voltages must all be equal, i.e., $DV_{DD} = AV_{DD} = V_{DD-M} = V_{DD-S}$. Descriptions are in terms of V_{DD} .

The grounds must all be equal, i.e., $DV_{SS} = AV_{SS} = V_{SS-M} = V_{SS-S}$. Descriptions are in terms of V_{SS} .

Switching Characteristics at $T_a = 25 \pm 2^\circ\text{C}$, $V_{DD} = 5\text{ V} \pm 10\%$, $V_{SS} = 0\text{ V}$

Parameter	Symbol	Conditions	min	typ	max	Unit
Vertical synchronization signal						
Pulse width	t_{VW}		1			μs
Rise time	t_{VR}				50	ns
Fall time	t_{VF}				50	ns
Horizontal synchronization signal						
Pulse width	t_{HW}		1			μs
Rise time	t_{HR}				50	ns
Fall time	t_{HF}				50	ns
I ² C timing						
SCL frequency	f_{SCL}				100	kHz
Bus release time	t_{BUF}		4.7			μs
Start hold time	t_{HD} : STA		4.0			μs
SCL low period	t_{LOW}		4.7			μs
SCL high period	t_{HIGH}		4.0			μs
Data hold time	t_{HD} : DAT		0			μs
Data setup time	t_{SU} : DAT		250			ns
Rise time	t_R				1000	ns
Fall time	t_F				300	ns
Stop setup time	t_{SU} : STO		4.0			μs

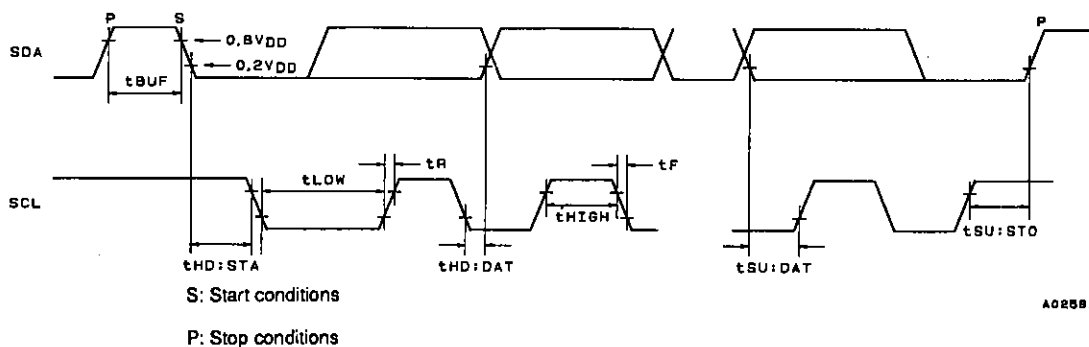

Synchronization Signal

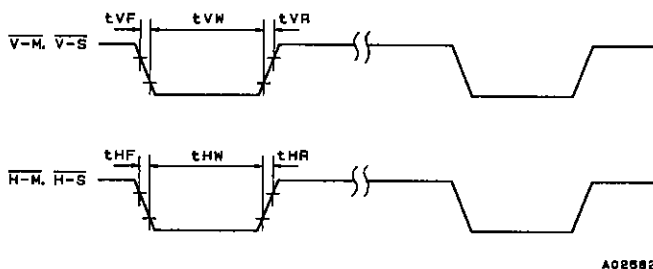

Sub-Screen Digital Processing Specifications

Item		NTSC ($f_H = 15734 \text{ Hz}$)	PAL ($f_H = 15625 \text{ Hz}$)
Sampling	Sequence	Y, R-Y, Y, B-Y, Y, -, Y, -, ...	
	Frequency	640 f_H	
	f_T (MHz)	10.070	10.000
	Y only	320 f_H	
	f_{TY}	5.035	5.000
	R-Y only	80 f_H	
	f_{TR}	1.258	1.250
Quantization bits	B-Y only	80 f_H	
	f_{TB}	1.258	1.250
D/A converter clock (MHz)*1	Y signal	6 bits	
	f_{CY}	15.105	15.000
	R-Y signal	240 f_H	
	f_{CR}	3.776	3.750
	B-Y signal	240 f_H	
Write	f_{CB}	3.776	3.750
	Horizontal dots	384	
	Y only	256	
	R-Y only	64	
	B-Y only	64	
Read and display*2	Vertical H count	80	84
	Horizontal dots	370	
	Y only	250	
	R-Y only	60	
	B-Y only	60	
	Vertical H count	77	83

Note: 1. When the PLL divisor has the standard value, i.e., PLL7 to PLL3 = 10011.

2. Approximate values.

(The number of horizontal dots depends on the frame width adjustment, and the vertical H count depends on address correction.)

Initialization

1. $\overline{\text{RES}}$ pin: Reset

The $\overline{\text{RES}}$ pin must be set low when power is first applied.

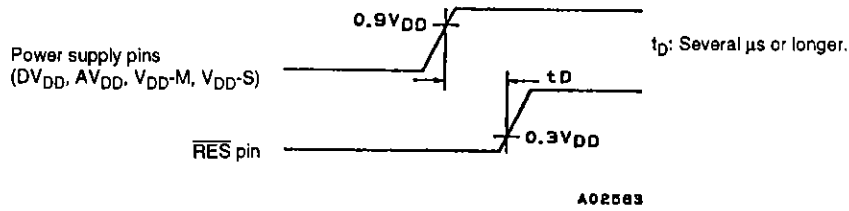

2. Internal control registers

These LSIs go to the standby state (SBY = high) after a reset. When developing microprocessor software, be sure to send data to all registers. Also be sure to send zero data to the zero registers at addresses 14H and 15H.

I²C Control

Data format

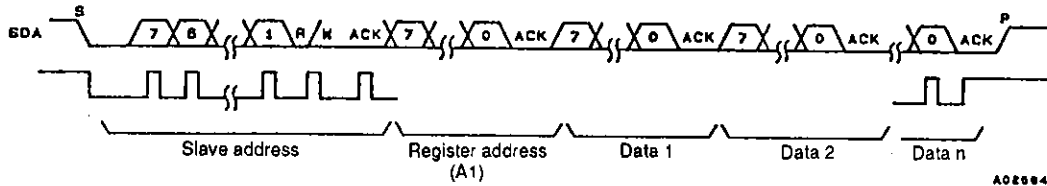

Data 1 is stored at register address A1. For data 2, A1 is incremented and data 2 is stored at A1 + 1.

Slave Address

A6	A5	A4	A3	A2	A1	A0	R/W
0	0	1	0	0	1	1	/

Synchronization Signal Input

1. Sync separator

The LC74401E requires sync separated (including AFC processing) V and H signals for both the main and sub-screens. Since V is used for frame determination and H is used as the PLL reference signal, these signals must be input reliably.

- The standard values are set up assuming that the $\overline{\text{H-M}}$ and $\overline{\text{H-S}}$ inputs are delayed about 1 μs from the video signal horizontal synchronization signal.



- Equalizing pulses must be removed.
- Since noise in the synchronization signal will disrupt the screen image, care must be used in the layout of these lines.
- We recommend turning off sub-screen display when the synchronization signals are unstable, since such instability can disrupt the sub-screen image.

2. Field determination circuit

Since the field is determined by the phase difference between the falling edges of the V and H signals, these signals must be input with the timing shown in the figure.

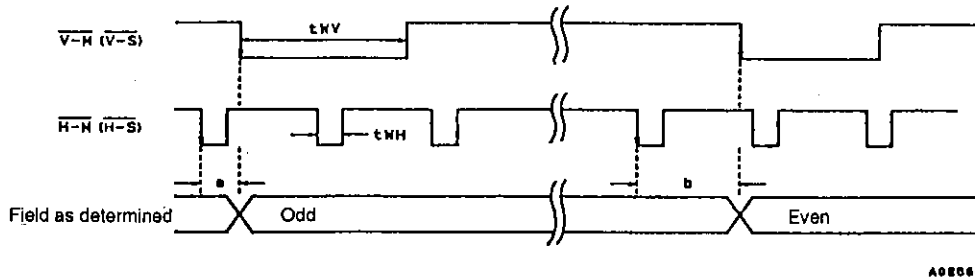

Here, a and b must be: $a = 0.02$ to $0.40 H$, $b = 0.60$ to $0.98 H$.
The synchronization signal pulse widths are: $t_{WV} > 1 \mu s$, $t_{WH} > 1 \mu s$.

Clamping Pulses

1. A/D converter clamping

Since clamping pulses are output with the timing shown in the figure, they must set to fall in the pedestal range. On a reset or during standby mode, the $\overline{H-S}$ input signal becomes a positive polarity signal, and is output as such.

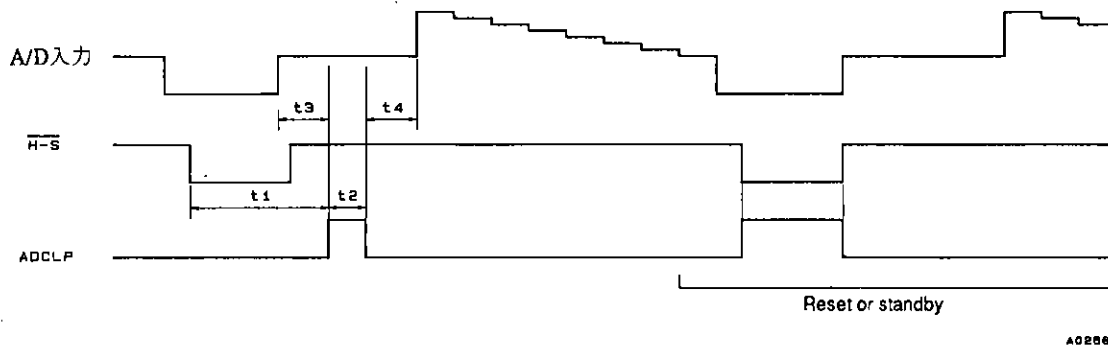

Note: Here, t_3 and t_4 must be: $t_3 > 0 \mu s$, $t_4 > 0.5 \mu s$.

2. D/A converter clamping

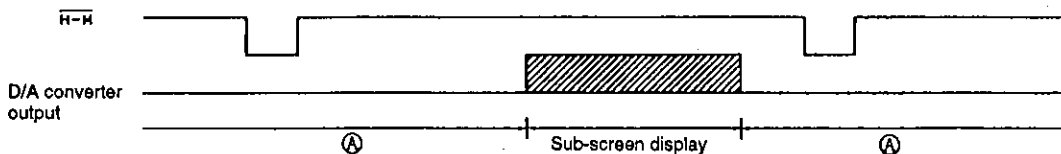

The digital data for the regions A is as follows:
Y D/A converter input: 000000
R-Y D/A converter input: 100000
B-Y D/A converter input: 100000
Clamping is applied on the main screen horizontal synchronization signal.

External Control Output Timing

1. A/D converter (LC7480) related signals

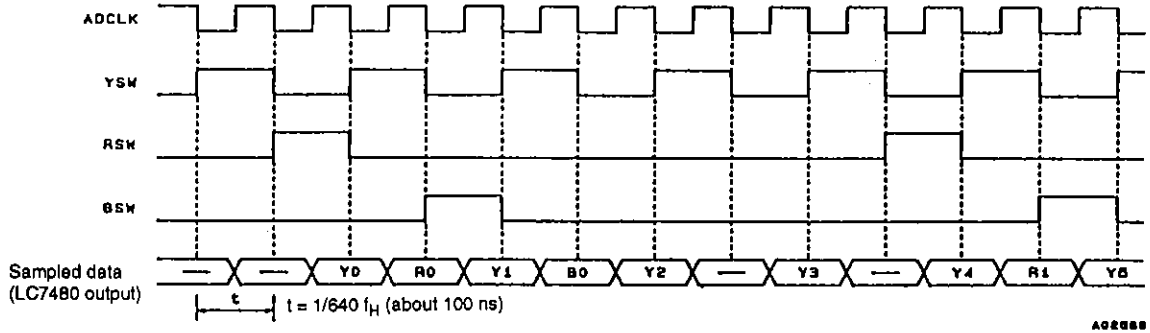

Note: Since these are high speed signals, care must be taken to keep their lines as short as possible.

2. Clamping related signals

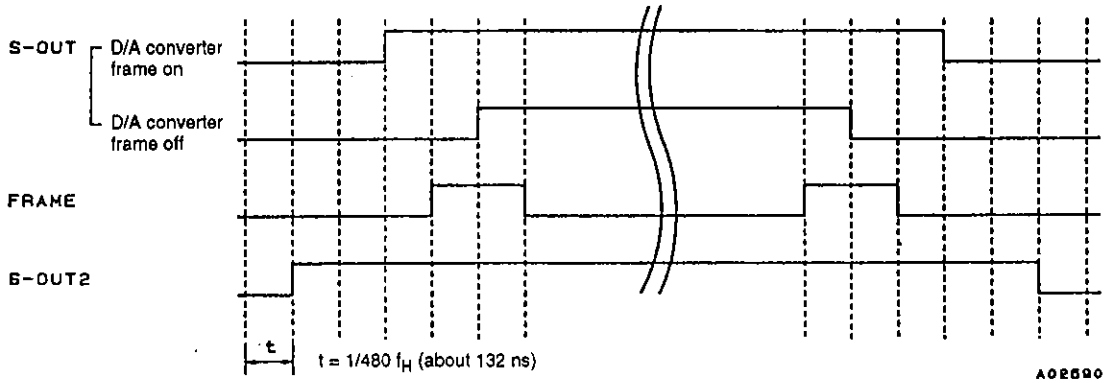

Note: The FRAME signal is only output in D/A converter frame off mode.

3. Video memory related signals

- Data write signals (page mode)

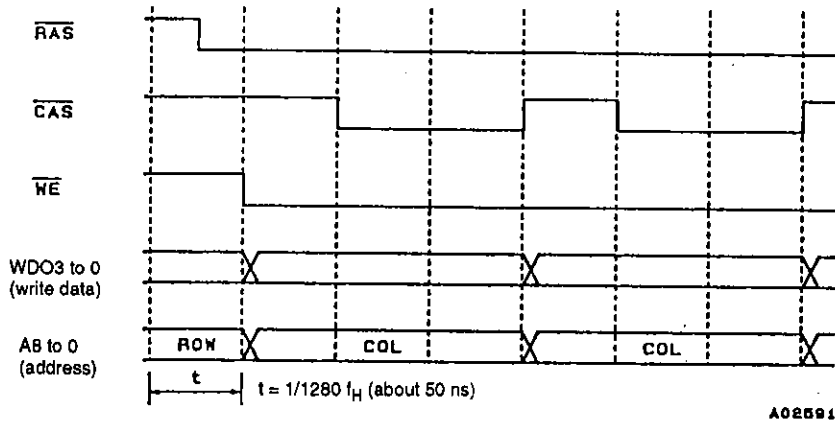

- Refresh signals (CAS before RAS)

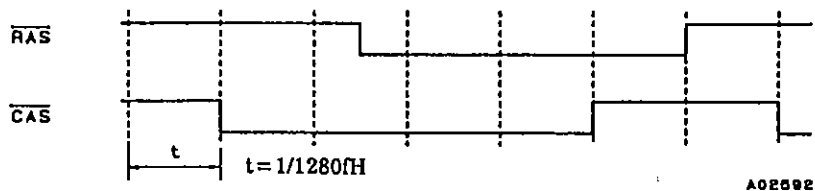

3. Data transfer → serial read

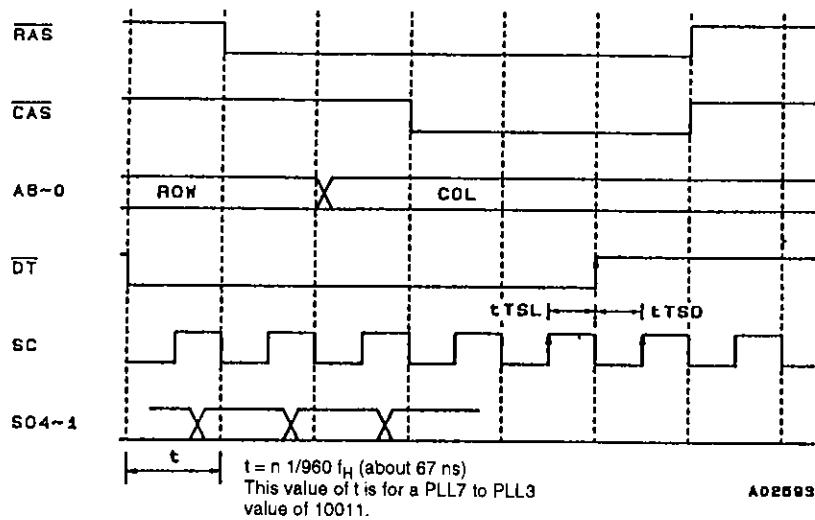

- Note: 1. Since these are high speed signals, care must be taken to keep their lines as short as possible.
 2. Contact your Sanyo representative when determining the memory to use.

- No products described or contained herein are intended for use in surgical implants, life-support systems, aerospace equipment, nuclear power control systems, vehicles, disaster/crime-prevention equipment and the like, the failure of which may directly or indirectly cause injury, death or property loss.
- Anyone purchasing any products described or contained herein for an above-mentioned use shall:
 - ① Accept full responsibility and indemnify and defend SANYO ELECTRIC CO., LTD., its affiliates, subsidiaries and distributors and all their officers and employees, jointly and severally, against any and all claims and litigation and all damages, cost and expenses associated with such use;
 - ② Not impose any responsibility for any fault or negligence which may be cited in any such claim or litigation on SANYO ELECTRIC CO., LTD., its affiliates, subsidiaries and distributors or any of their officers and employees jointly or severally.
- Information (including circuit diagrams and circuit parameters) herein is for example only; it is not guaranteed for volume production. SANYO believes information herein is accurate and reliable, but no guarantees are made or implied regarding its use or any infringements of intellectual property rights or other rights of third parties.

This catalog provides information as of **June, 1996**. Specifications and information herein are subject to change without notice.