

Applications

- Low cost general-purpose clock source

General Description

The VT98521 is a 3.3V CMOS, clock multiplier integrated circuit. The device provides an excellent quality high frequency output clock from a lower frequency crystal or clock input. Tri-level selection inputs S0 and S1 are used to select any one of eight multipliers, stored in the on-board ROM, and apply it to the input to produce the desired output, up to 220 MHz. Phase Locked Loop (PLL) technology allows the device to use an input signal from an inexpensive crystal. When Output Enable (OE) is low, the clock output is in high impedance state.

The VT98521, when used with an inexpensive crystal, provides a cost-effective clock source for most electronic systems.

Features

- Low phase noise
- Zero ppm multiplication error
- Input clock frequency 5 - 50 MHz.
- Input crystal frequency 5 – 27 MHz
- Output clock frequencies up to 220 MHz.
- 5V-tolerant inputs and output
- Fully Compatible with all popular CPUs
- Duty Cycle - 45/55 up to 160 MHz.
- 40/60 160 MHz to 220 MHz
- 25mA drive capability at TTL levels
- High-Z output for board level testing

Figure 1. Functional Block Diagram

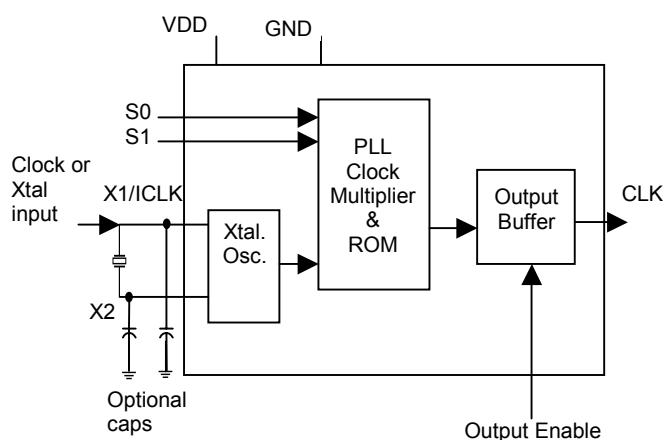

Figure 2. Pin Assignment

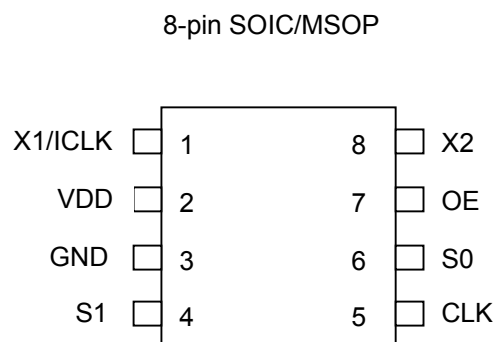

Table 1. Clock Output Table

S1	S0	CLK	Minimum Input
0	0	4 x input	See table 6
0	M	5.3125 x input	20 MHz
0	1	5 x input	See table 6
M	0	6.25 x input	4 MHz
M	M	Test*	
M	1	3.125 x input	8 MHz
1	0	6 x input	See table 6
1	M	3 x input	See table 6
1	1	8 x input	See table 6

0 = Connect to ground.

1 = Connect directly to VDD

M = Leave unconnected (floating)

* = For Vaishali internal test purposes only

Table 2. Pin Description

No.	Name	Type	Description
1	X1/ICLK	I	Xtal connection or clock input.
2	VDD	P	Connect to +3.3V
3	GND	P	Connect to ground.
4	S1	TI	Select 1 for output clock. Connect to ground or VDD or float
5	CLK	O	Clock output per table 2.
6	S0	TI	Select 0 for output clock. Connect to ground or VDD or float.
7	OE	I	Output Enable. Tri- states CLK output when low.
8	X2	O	Xtal connection. Leave unconnected for clock input.

Legend:

I = Input

TI = Tri-level Input

O = Output

P = Power supply connection

Table 3. Absolute Maximum Ratings

Parameter	Conditions	Min	Typ	Max	Units
Supply voltage, VDD	Referenced to GND			4.6	V
Inputs and Clock Outputs	Referenced to GND	-0.5		4.6	V
Soldering Temperature	Max of 10 seconds			260	°C
Storage temperature		-65		150	°C

Table 4. Operating Conditions

Parameter	Min	Typ	Max	Units
Ambient Operating Temperature	0		70	°C
Operating Voltage, VDD	3		3.6	V
Input High Voltage, V_{IH} , X1 pin only	2.5	1.65		V
Input Low Voltage, V_{IL} , X1 pin only		1.65	0.5	V
Input High Voltage, V_{IH} , OE pin	2			V
Input Low Voltage, V_{IL} , OE pin			0.8	V
Input High Voltage, V_{IH} , trinary inputs	VDD-0.5			V
Input Low Voltage, V_{IL} , trinary inputs			0.5	V

DC Characteristics

Table 5. DC Characteristics

VDD = 3V to 3.6V

Parameter	Condition	Min	Typ	Max	Units
Output High Voltage, V_{OH}	$I_{OH}=-25mA$	2.4			V
Output Low Voltage, V_{OL}	$I_{OL}=25mA$			0.4	V
Operating Supply Current, I_{DD} (20 MHz Xtal)	No Load, 100MHz		25		mA
Short Circuit Current	CLK output		±100		mA
Input Capacitance	S0, S1, OE, X1, X2		4		pF
Frequency synthesis error				0	ppm

AC Characteristics

Table 6 AC Characteristics

VDD = 3V to 3.6V over the operating temperature range

Symbol	Parameter	Condition	Min	Typ	Max	Units
f_{osc}	Input Crystal Frequency		5		27	MHz
f_{in}	Input clock frequency		5		50	MHz
f_{out}	Output Frequency,		24		220	MHz
t_r	Output Clock Rise Time	0.8 to 2.0V		1		ns
t_f	Output Clock Fall Time	2.0 to 0.8V		1		ns
t_{od}	Output Clock Duty Cycle	1.5 V up to 160 MHz	45	49 to 51	55	%
		160 MHz to 220 MHz	40		60	%
	PLL Bandwidth		10			kHz
T_{PZH}, T_{PZL}	Output Enable Time, OE high to output on				50	ns
T_{PHZ}, T_{PLZ}	Output Disable time, OE low to Tri-state				50	ns
$t_{jit} (abs)$	Absolute Clock period Jitter	Deviation from mean $f_{out} = 160$ MHz		70		ps
$t_{jit} (sigma)$	One Sigma Clock Period Jitter	$f_{out} = 160$ MHz		25		ps

Note1: External Crystal Connection.

The external crystal should be connected in as close physical proximity to the VT98521 as possible. The crystal should be a fundamental mode, parallel resonant. Do not use third overtone. External load capacitors should be fitted in accordance with the crystal manufacturer's specifications.

Note2: Decoupling and termination.

Decoupling capacitors of 0.01 μ F and 0.1 μ F should be connected between VDD and Ground. Capacitors should be mounted as close to the chip as possible. A 33 Ω termination resistor may be connected in series with the clock output in order to minimize ringing and reflections.

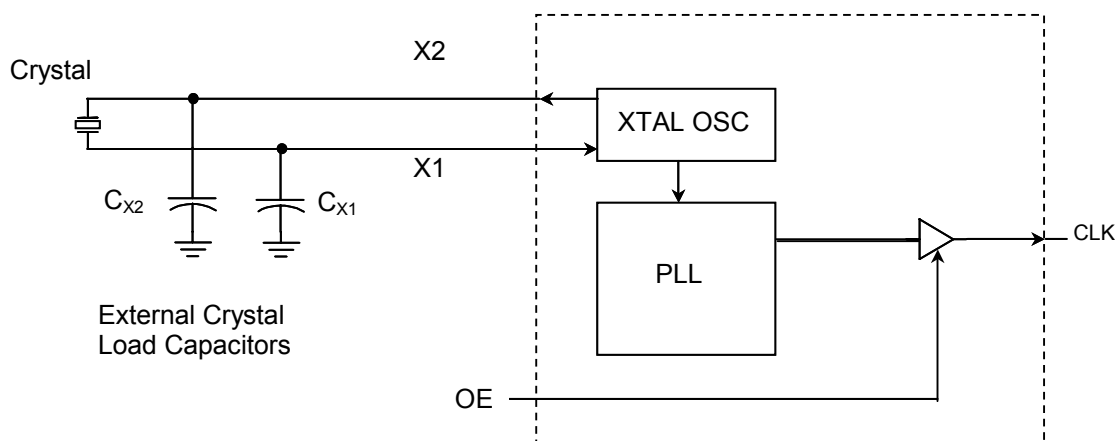
Figure 3. External Crystal Connection Block Diagram

Package Dimensions.

MSOP

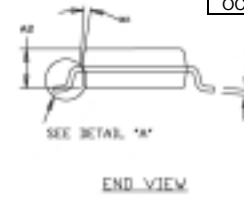
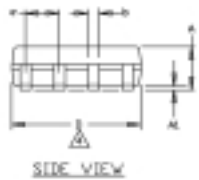
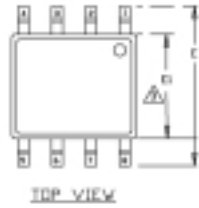

SYMBOLS	VARIATIONS (ALL ARE IN MM)		
	AA		
	MIN	NOM	MAX
A	-	-	1.1
A1	0	-	0.15
A2	0.75	0.85	0.95
b	0.22	-	0.38
c	0.08	-	0.23
D	3.00 BSC		
E	4.90 BSC		
E1	3.00 BSC		
L	0.4	0.6	0.8
e	0.65		
oc	0°	-	8°
OC1	5°	-	15°

All dimensions are in millimeters

SOIC

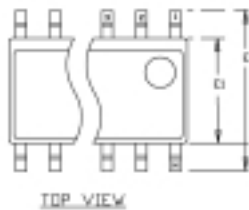

SYMBOLS	VARIATIONS (ALL ARE IN MM)		
	AA		
	MIN	NOM	MAX
A	1.35	1.55	1.75
A1	.011	-	0.25
B	0.33	0.42	0.51
C	0.19	0.22	0.25
D	4.80	4.90	5.00
E1	3.80	3.90	4.00
e	1.27 BSC		
E	5.80	6.00	6.20
h	0.25	0.38	0.50
oc	0°	5°	8°
L	0.40	-	1.27
N	8		

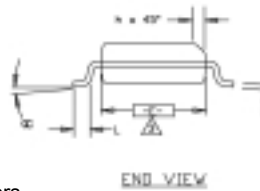
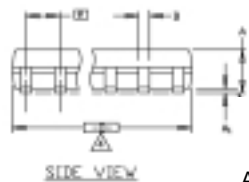

All dimensions are in millimeters

Ordering Information

Part Number	Marking	Shipping/Packaging	No. of Pins	Package	Temperature
VT98521S1	VT98521S1	Tubes	8	SOIC	0°C to +70°C
VT98521S1X	VT98521S1	Tape & Reel	8	SOIC	0°C to +70°C
VT98521M	VT98521M	Tubes	8	MSOP	0°C to +70°C
VT98521MX	VT98521M	Tape & Reel	8	MSOP	0°C to +70°C
VT98521/D		Dice in waffle-packs			0°C to +70°C
VT98521/DW		Dice in wafer form			0°C to +70°C