

Advance Information

MPC8241TXXPNS  
Rev. 1, 8/2003

MPC8241 Part Number  
Specification for the  
XPC8241TXXnnx Series



Motorola Part  
Numbers Affected:  
XPC8241TZP166B  
MPC8241TZQ166D  
XPC8241TZP200B  
MPC8241TZQ266D

This document describes part-number-specific changes to recommended operating conditions and revised electrical specifications, as applicable, from those described in the general *MPC8241 Integrated Processor Hardware Specifications* (Order No. MPC8241EC/D). The MPC8241 combines a MPC603e PowerPC™ core microprocessor with a PCI bridge.

Specifications provided in this document supersede those in the *MPC8241 Integrated Processor Hardware Specifications*, Rev. 0.3 or later, for the part numbers listed in Table A only. Specifications not addressed herein are unchanged. Because this document is frequently updated, refer to <http://www.motorola.com/semiconductors> or to your Motorola sales office for the latest version.

Note that headings and table numbers in this document are not consecutively numbered. They are intended to correspond to the heading or table affected in the general hardware specification.

Part numbers addressed in this document are listed in Table A. For more detailed ordering information see Section 1.9, "Ordering Information."

Table A. Part Numbers Addressed by this Data Sheet

Motorola Part Number <sup>1</sup>	Operating Conditions			Significant Differences from Hardware Specification	Processor Version Register Value
	CPU Frequency (MHz)	V <sub>DD</sub>	T <sub>J</sub> (°C)		
XPC8241TZP166B MPC8241TZQ166D	166	1.8 ± 100 mV	-40 to 105	Extended temperature range for additional part offering	0x80811014
XPC8241TZP200B MPC8241TZQ166D	200				
MPC8241TZQ266D	266				

**Note:** The X prefix in a Motorola part number designates a "Pilot Production Prototype" as defined by Motorola SOP 3-13. These are from a limited production volume of prototypes manufactured, tested, and Q.A. inspected on a qualified technology to simulate normal production. These parts have only preliminary reliability and characterization data. Before pilot production prototypes may be shipped, written authorization from the customer must be on file in the applicable sales office acknowledging the qualification status and the fact that product changes may still occur while shipping pilot production prototypes.

<sup>1</sup> ZP = PGBA, ZQ = thick substrate and thick mold cap PBGA.

### 1.4.1.2 DC Electrical Characteristics

Table 2 provides the recommended operating conditions for the MPC8241 part numbers described herein.

**Table 2. Recommended Operating Conditions**

Characteristic	Symbol	Recommended Value	Unit
Die-junction temperature	$T_J$	-40 to 105	°C

**Note:** These are the recommended and tested operating conditions. Proper device operation outside of these conditions is not guaranteed.

Refer to the *MPC8241 Integrated Processor Hardware Specifications* for more details concerning the part number specifications.

## 1.9 Ordering Information

This section provides the part numbering nomenclature for the MPC8241. Note that the individual part numbers correspond to a maximum processor core frequency. For available frequencies, contact your local Motorola sales office.

Figure 33 provides the Motorola part numbering nomenclature for the MPC8241. In addition to the processor frequency, the part numbering scheme also consists of an application modifier. The application modifier may specify special application conditions, such as specific temperature or voltage ranges. Each part number also contains a revision code. This refers to the die mask revision number and is specified in the part numbering scheme for identification purposes only.

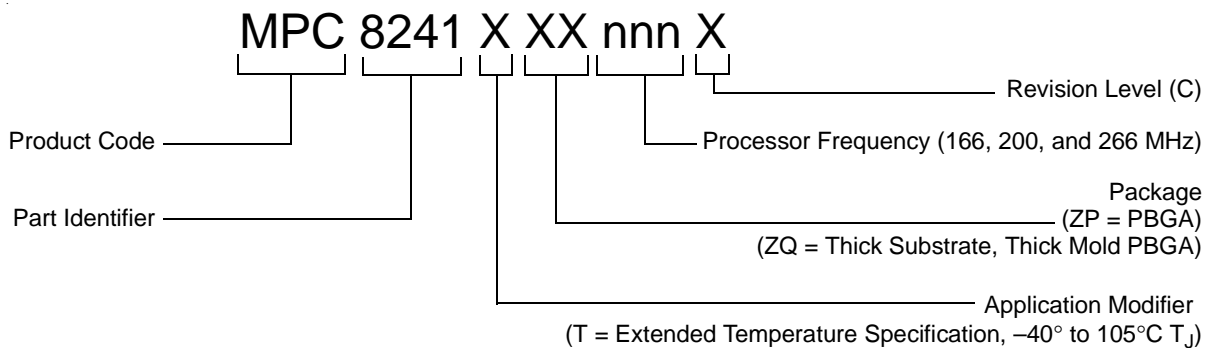

**Figure 33. Motorola Part Number Key**

## Document Revision History

Table B provides a revision history for this part number specification.

**Table B. Document Revision History**

Rev. No.	Substantive Change(s)
0	Initial release.
1	Updated part listing on first page and in Table A. Table A—Added 266 MHz part to list of parts offered for extended temperature offerings. Also, added Processor Version Number column to table. Updated list of extended temperature parts. Section 1.9—Updated part marking format and package description offerings.

# Freescale Semiconductor, Inc.

## HOW TO REACH US:

### USA/EUROPE/LOCATIONS NOT LISTED:

Motorola Literature Distribution  
P.O. Box 5405, Denver, Colorado 80217  
1-303-675-2140  
(800) 441-2447

### JAPAN:

Motorola Japan Ltd.  
SPS, Technical Information Center  
3-20-1, Minami-Azabu Minato-ku  
Tokyo 106-8573 Japan  
81-3-3440-3569

### ASIA/PACIFIC:

Motorola Semiconductors H.K. Ltd.  
Silicon Harbour Centre, 2 Dai King Street  
Tai Po Industrial Estate, Tai Po, N.T., Hong Kong  
852-26668334

### TECHNICAL INFORMATION CENTER:

(800) 521-6274

### HOME PAGE:

[www.motorola.com/semiconductors](http://www.motorola.com/semiconductors)

Information in this document is provided solely to enable system and software implementers to use Motorola products. There are no express or implied copyright licenses granted hereunder to design or fabricate any integrated circuits or integrated circuits based on the information in this document.

Motorola reserves the right to make changes without further notice to any products herein.

Motorola makes no warranty, representation or guarantee regarding the suitability of its products for any particular purpose, nor does Motorola assume any liability arising out of the application or use of any product or circuit, and specifically disclaims any and all liability, including without limitation consequential or incidental damages. "Typical" parameters which may be provided in Motorola data sheets and/or specifications can and do vary in different applications and actual performance may vary over time. All operating parameters, including "Typicals" must be validated for each customer application by customer's technical experts. Motorola does not convey any license under its patent rights nor the rights of others. Motorola products are not designed, intended, or authorized for use as components in systems intended for surgical implant into the body, or other applications intended to support or sustain life, or for any other application in which the failure of the Motorola product could create a situation where personal injury or death may occur. Should Buyer purchase or use Motorola products for any such unintended or unauthorized application, Buyer shall indemnify and hold Motorola and its officers, employees, subsidiaries, affiliates, and distributors harmless against all claims, costs, damages, and expenses, and reasonable attorney fees arising out of, directly or indirectly, any claim of personal injury or death associated with such unintended or unauthorized use, even if such claim alleges that Motorola was negligent regarding the design or manufacture of the part.



Motorola and the Stylized M Logo are registered in the U.S. Patent and Trademark Office. digital dna is a trademark of Motorola, Inc. The PowerPC name is a trademark of IBM Corp. and is used under license. All other product or service names are the property of their respective owners. Motorola, Inc. is an Equal Opportunity/Affirmative Action Employer.

© Motorola, Inc. 2003

MPC8241TXXPNS

**For More Information On This Product,  
Go to: [www.freescale.com](http://www.freescale.com)**