

---

# HM52Y64165F Series

# HM52Y64805F Series

# HM52Y64405F Series

64M SDRAM

133 MHz/125 MHz

1-Mword  $\times$  16-bit  $\times$  4-bank/2-Mword  $\times$  8-bit  $\times$  4-bank  
/4-Mword  $\times$  4-bit  $\times$  4-bank

# HITACHI

ADE-203-974 (Z)

Preliminary

Rev. 0.0

Oct. 30, 1998

---

## Description

The Hitachi HM52Y64165F is a 64-Mbit SDRAM organized as 1048576-word  $\times$  16-bit  $\times$  4 bank. The Hitachi HM52Y64805F is a 64-Mbit SDRAM organized as 2097152-word  $\times$  8-bit  $\times$  4 bank. The Hitachi HM52Y64405F is a 64-Mbit SDRAM organized as 4194304-word  $\times$  4-bit  $\times$  4 bank. All inputs and outputs are referred to the rising edge of the clock input. It is packaged in standard 54-pin plastic TSOP II.

## Features

- 2.5 V power supply
- Clock frequency: 133 MHz/125 MHz (max)
- Single pulsed  $\overline{RAS}$
- 4 banks can operate simultaneously and independently
- Burst read/write operation and burst read/single write operation capability
- Programmable burst length: 1/2/4/8/full page
- 2 variations of burst sequence
  - Sequential (BL = 1/2/4/8/full page)
  - Interleave (BL = 1/2/4/8)
- Programmable  $\overline{CAS}$  latency: 2/3
- Byte control by DQM:DQM (HM52Y64805F/HM52Y64405F)  
: DQMU/DQML (HM52Y64165F)
- Refresh cycles: 4096 refresh cycles/64 ms
- 2 variations of refresh
  - Auto refresh
  - Self refresh
- Full page burst length capability
  - Sequential burst

— Burst stop capability

## Ordering Information

Type No.	Frequency	Package
HM52Y64165FTT-75	133 MHz	400-mil 54-pin plastic TSOP II (TTP-54D)
HM52Y64165FTT-80	125 MHz	
HM52Y64805FTT-75	133 MHz	
HM52Y64805FTT-80	125 MHz	
HM52Y64405FTT-75	133 MHz	
HM52Y64405FTT-80	125 MHz	

## Pin Arrangement (HM52Y64165F)

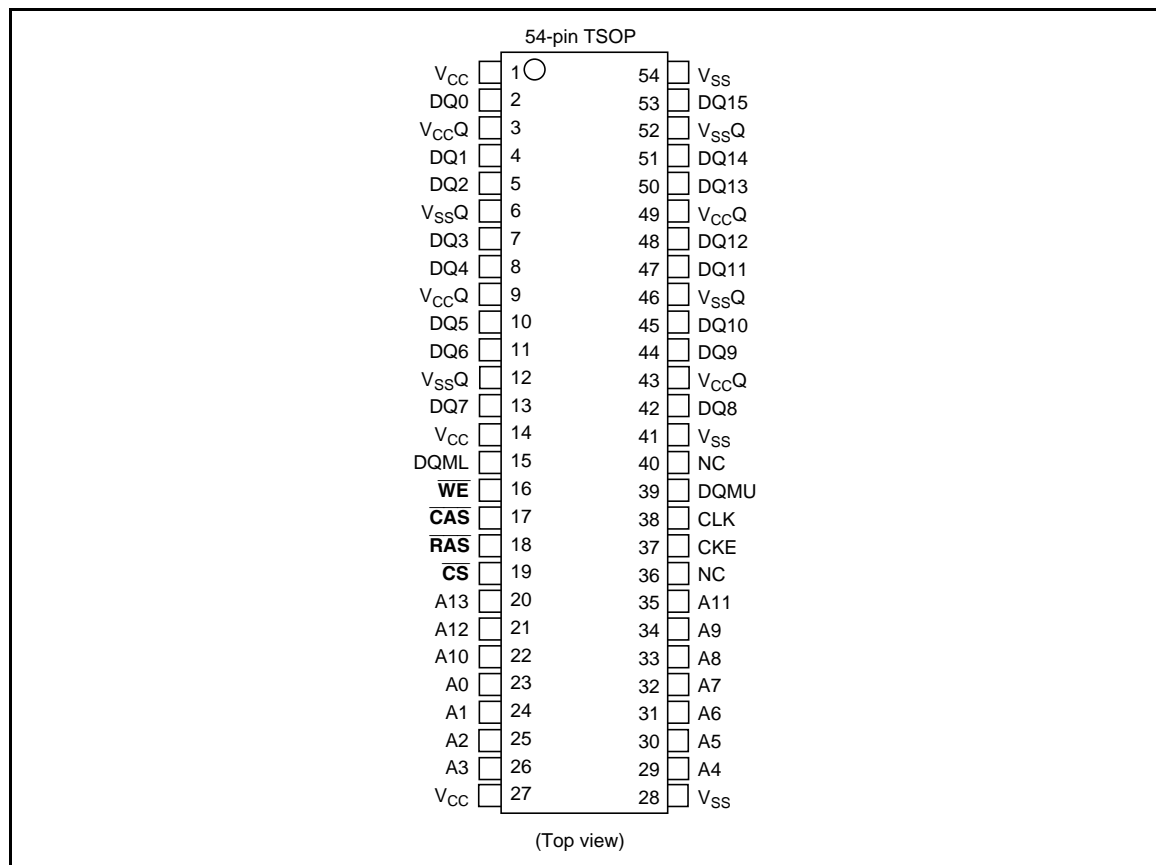

## Pin Description

Pin name	Function	Pin name	Function
A0 to A13	Address input	$\overline{WE}$	Write enable
	Row address A0 to A11	DQMU/DQML	Input/output mask
	Column address A0 to A7	CLK	Clock input
	Bank select address A12/A13 (BS)	CKE	Clock enable
DQ0 to DQ15	Data-input/output	V <sub>CC</sub>	Power for internal circuit

Pin name	Function	Pin name	Function
$\overline{\text{CS}}$	Chip select	$V_{SS}$	Ground for internal circuit
$\overline{\text{RAS}}$	Row address strobe command	$V_{CCQ}$	Power for DQ circuit
$\overline{\text{CAS}}$	Column address strobe command	$V_{SSQ}$	Ground for DQ circuit
		NC	No connection

## Pin Arrangement (HM52Y64805F)

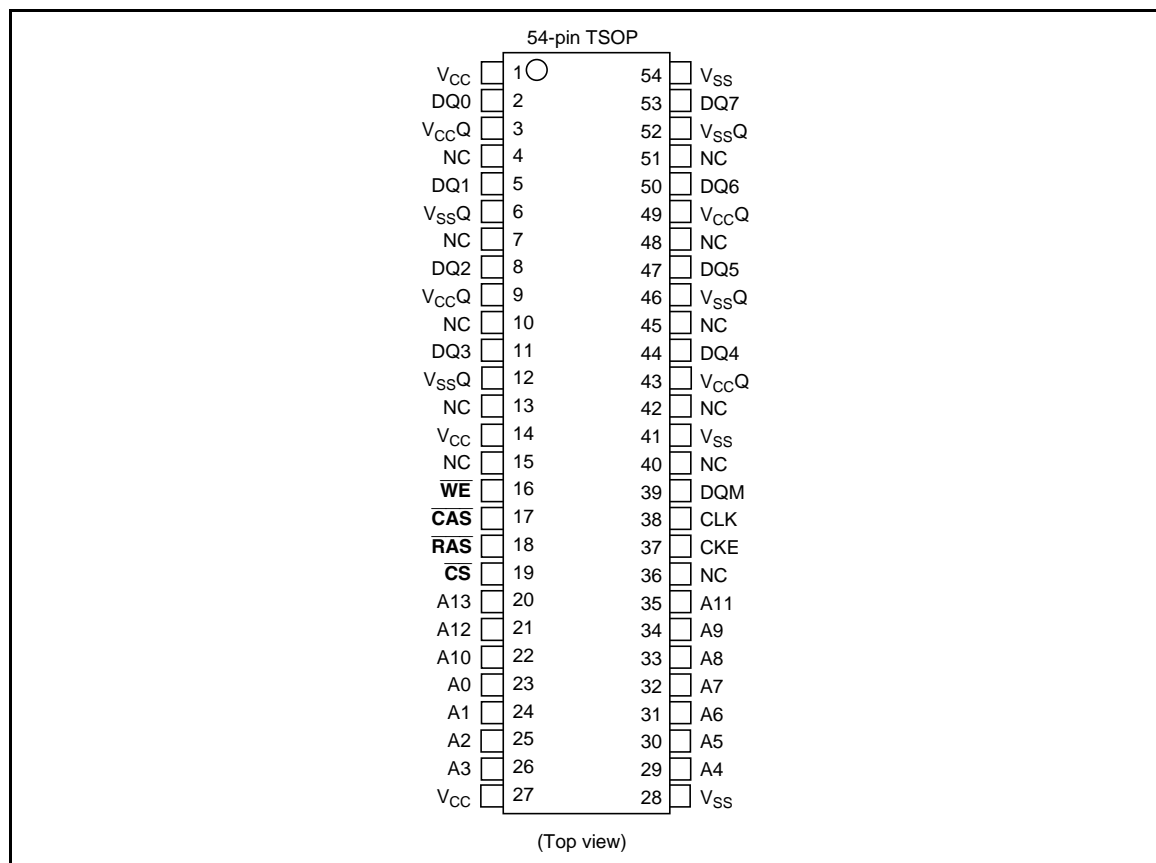

## Pin Description

Pin name	Function	Pin name	Function
A0 to A13	Address input	$\overline{\text{WE}}$	Write enable
	Row address    A0 to A11	DQM	Input/output mask
	Column address    A0 to A8	CLK	Clock input
	Bank select address    A12/A13 (BS)	CKE	Clock enable
DQ0 to DQ7	Data-input/output	$V_{CC}$	Power for internal circuit
$\overline{\text{CS}}$	Chip select	$V_{SS}$	Ground for internal circuit
$\overline{\text{RAS}}$	Row address strobe command	$V_{CCQ}$	Power for DQ circuit
$\overline{\text{CAS}}$	Column address strobe command	$V_{SSQ}$	Ground for DQ circuit
		NC	No connection

## Pin Arrangement (HM52Y64405F)

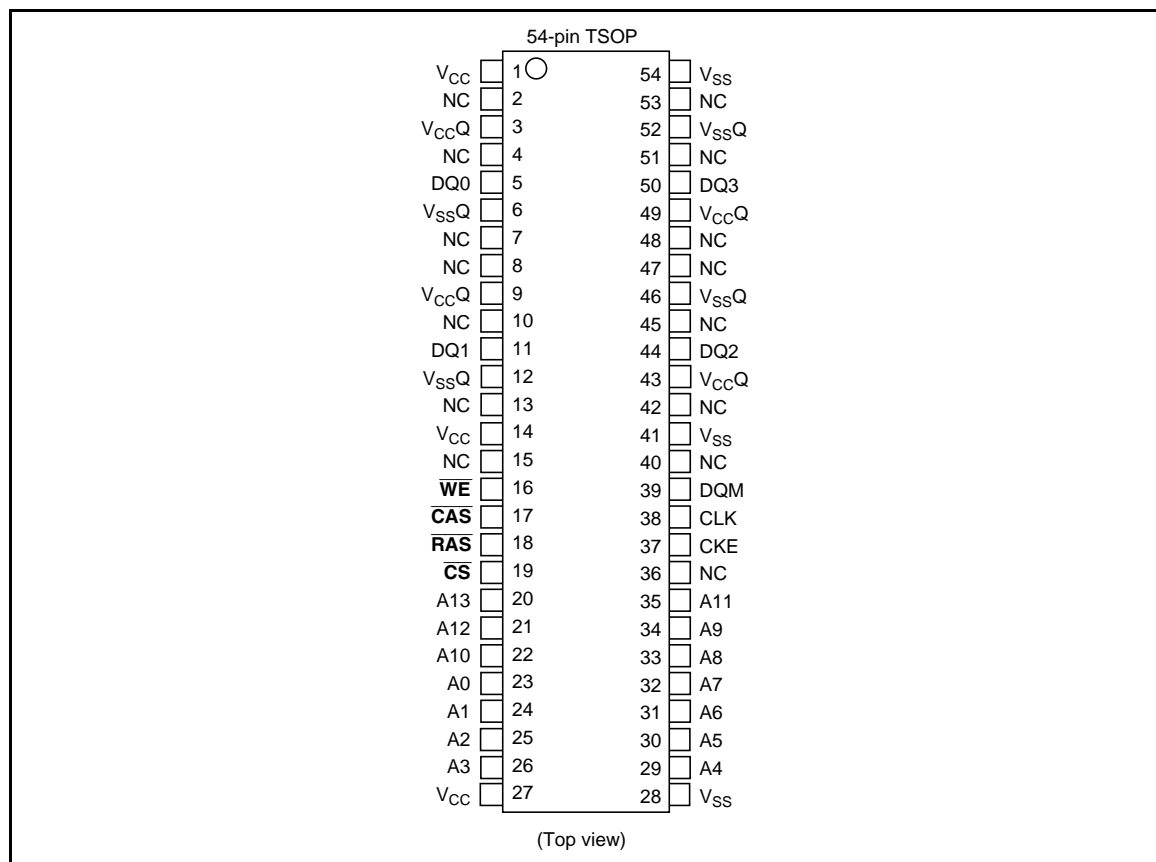

## Pin Description

Pin name	Function	Pin name	Function
A0 to A13	Address input	$\overline{\text{WE}}$	Write enable
	Row address    A0 to A11	DQM	Input/output mask
	Column address    A0 to A9	CLK	Clock input
	Bank select address    A12/A13 (BS)	CKE	Clock enable
DQ0 to DQ3	Data-input/output	V <sub>CC</sub>	Power for internal circuit
$\overline{\text{CS}}$	Chip select	V <sub>SS</sub>	Ground for internal circuit
$\overline{\text{RAS}}$	Row address strobe command	V <sub>CCQ</sub>	Power for DQ circuit
$\overline{\text{CAS}}$	Column address strobe command	V <sub>SSQ</sub>	Ground for DQ circuit
		NC	No connection

Block Diagram (HM52Y64165F)

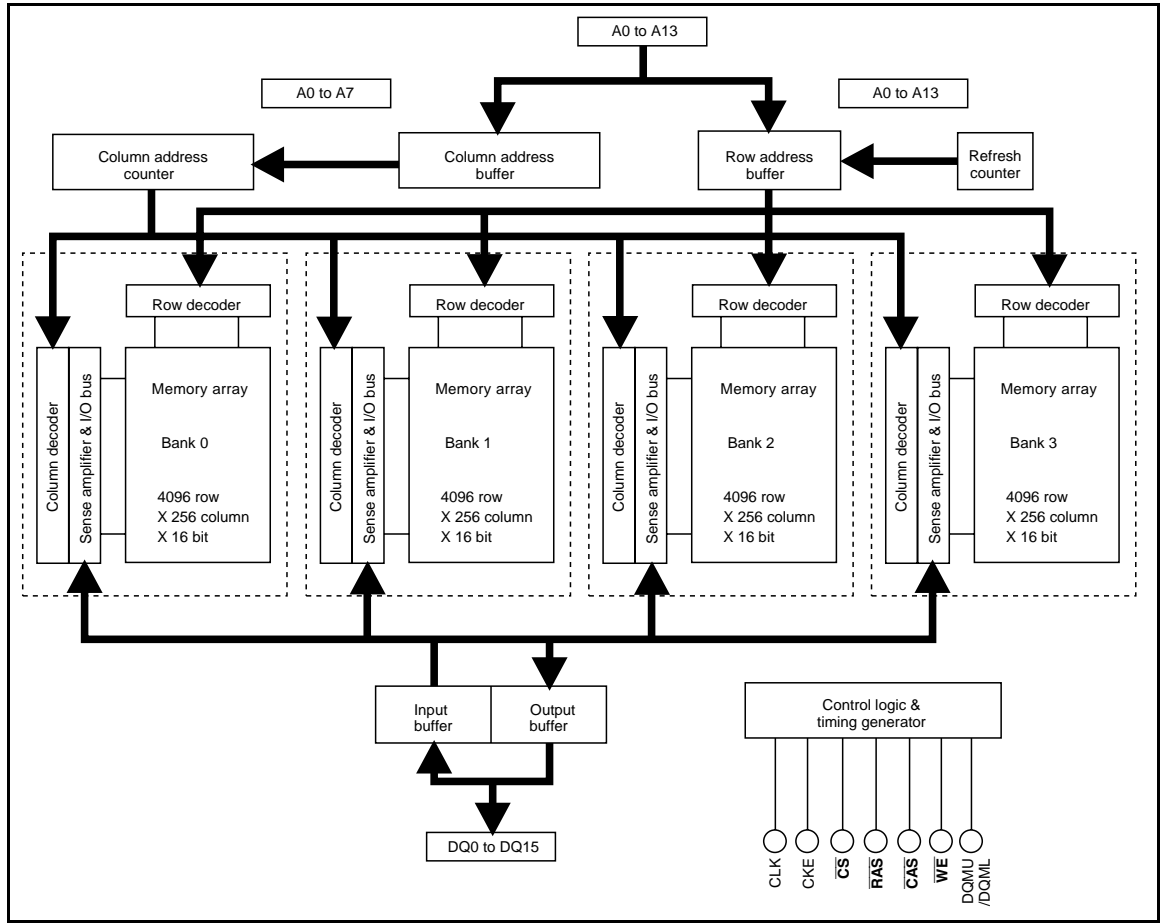

Block Diagram (HM52Y64805F)

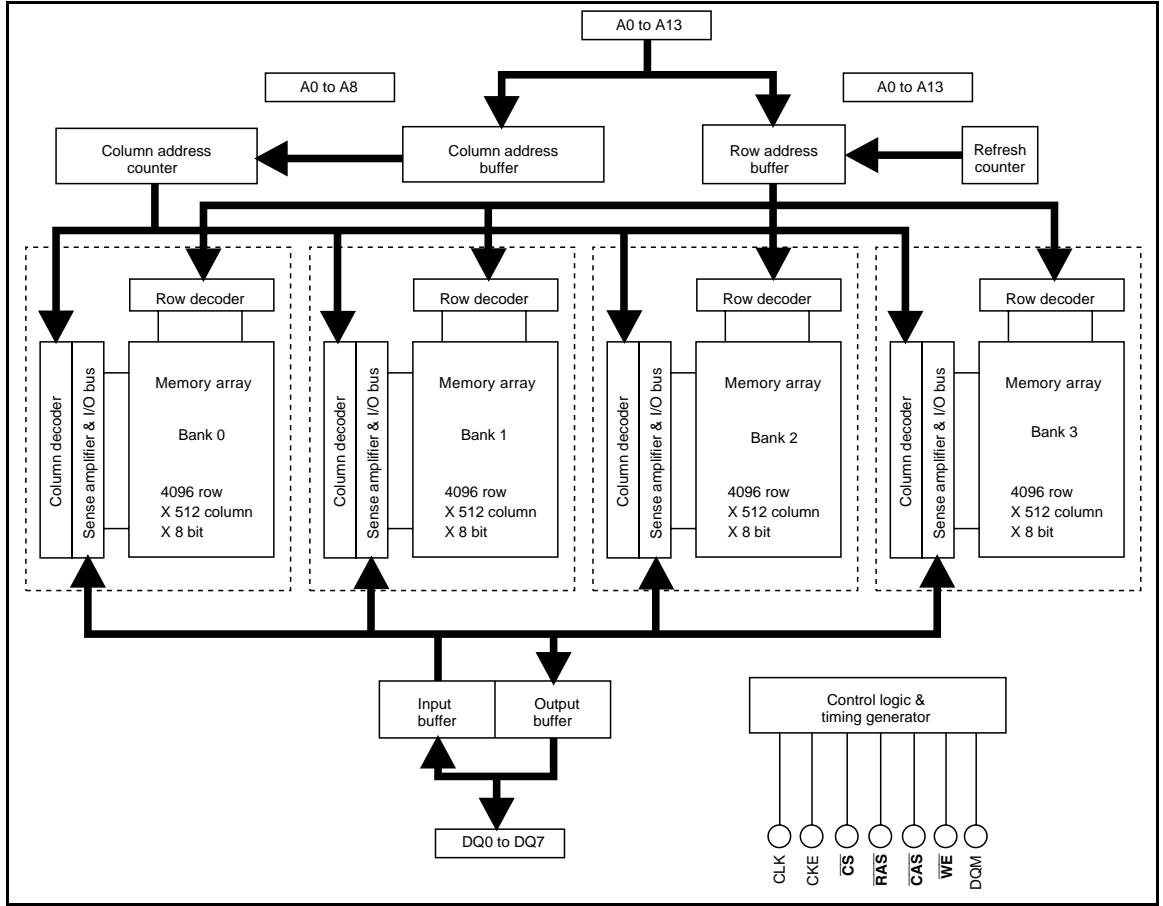

## Block Diagram (HM52Y64405F)

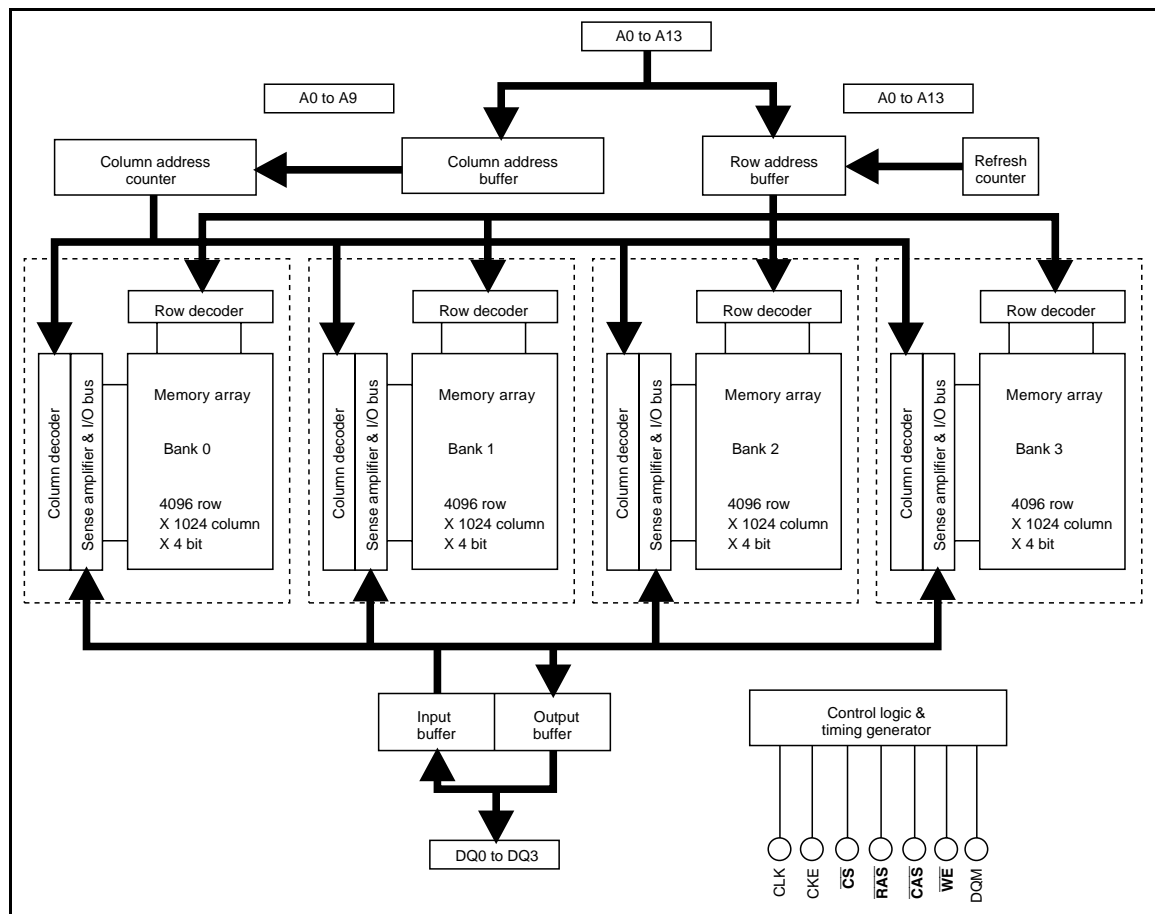

## Pin Functions

**CLK (input pin):** CLK is the master clock input to this pin. The other input signals are referred at CLK rising edge.

**$\overline{\text{CS}}$  (input pin):** When  $\overline{\text{CS}}$  is Low, the command input cycle becomes valid. When  $\overline{\text{CS}}$  is High, all inputs are ignored. However, internal operations (bank active, burst operations, etc.) are held.

**$\overline{\text{RAS}}$ ,  $\overline{\text{CAS}}$ , and  $\overline{\text{WE}}$  (input pins):** Although these pin names are the same as those of conventional DRAMs, they function in a different way. These pins define operation commands (read, write, etc.) depending on the combination of their voltage levels. For details, refer to the command operation section.

**A0 to A11 (input pins):** Row address (AX0 to AX11) is determined by A0 to A11 level at the bank active command cycle CLK rising edge. Column address (AY0 to AY7; HM52Y64165F, AY0 to AY8; HM52Y64805F, AY0 to AY9; HM52Y64405F) is determined by A0 to A7, A8 or A9 (A7; HM52Y64165F, A8; HM52Y64805F, A9; HM52Y64405F) level at the read or write command cycle CLK rising edge. And this column address becomes burst access start address. A10 defines the precharge mode. When A10 = High at the precharge command cycle, all banks are precharged. But when A10 = Low at the precharge command cycle, only the bank that is selected by A12/A13 (BS) is precharged. For details refer to the command operation section.

**A12/A13 (input pin):** A12/A13 are bank select signal (BS). The memory array of the HM52Y64165F, HM52Y64805F, the HM52Y64405F is divided into bank 0, bank 1, bank 2 and bank 3. HM52Y64165F contain 4096-row × 256-column × 16-bit. HM52Y64805F contain 4096-row × 512-column × 8-bit. HM52Y64405F contain 4096-row × 1024-column × 4-bit. If A12 is Low and A13 is Low, bank 0 is selected. If A12 is High and A13 is Low, bank 1 is selected. If A12 is Low and A13 is High, bank 2 is selected. If A12 is High and A13 is High, bank 3 is selected.

**CKE (input pin):** This pin determines whether or not the next CLK is valid. If CKE is High, the next CLK rising edge is valid. If CKE is Low, the next CLK rising edge is invalid. This pin is used for power-down mode, clock suspend mode and self refresh mode.

**DQM, DQMU/DQML (input pins):** DQM, DQMU/DQML controls input/output buffers.

**Read operation:** If DQM, DQMU/DQML is High, the output buffer becomes High-Z. If the DQM, DQMU/DQML is Low, the output buffer becomes Low-Z. (The latency of DQM, DQMU/DQML during reading is 2 clocks.)

**Write operation:** If DQM, DQMU/DQML is High, the previous data is held (the new data is not written). If DQM, DQMU/DQML is Low, the data is written. (The latency of DQM, DQMU/DQML during writing is 0 clock.)

**DQ0 to DQ15 (DQ pins):** Data is input to and output from these pins (DQ0 to DQ15; HM52Y64165F, DQ0 to DQ7; HM52Y64805F, DQ0 to DQ3; HM52Y64405F).

**V<sub>CC</sub> and V<sub>CCQ</sub> (power supply pins):** 2.5 V is applied. (V<sub>CC</sub> is for the internal circuit and V<sub>CCQ</sub> is for the output buffer.)

**V<sub>SS</sub> and V<sub>SSQ</sub> (power supply pins):** Ground is connected. (V<sub>SS</sub> is for the internal circuit and V<sub>SSQ</sub> is for the output buffer.)

## Command Operation

### Command Truth Table

The SDRAM recognizes the following commands specified by the  $\overline{\text{CS}}$ ,  $\overline{\text{RAS}}$ ,  $\overline{\text{CAS}}$ ,  $\overline{\text{WE}}$  and address pins.

Command	Symbol	CKE		$\overline{\text{CS}}$	$\overline{\text{RAS}}$	$\overline{\text{CAS}}$	$\overline{\text{WE}}$	A12/	A0	
		n - 1	n					A13	A10	to A11
Ignore command	DESL	H	×	H	×	×	×	×	×	×
No operation	NOP	H	×	L	H	H	H	×	×	×
Burst stop in full page	BST	H	×	L	H	H	L	×	×	×
Column address and read command	READ	H	×	L	H	L	H	V	L	V
Read with auto-precharge	READ A	H	×	L	H	L	H	V	H	V
Column address and write command	WRIT	H	×	L	H	L	L	V	L	V
Write with auto-precharge	WRIT A	H	×	L	H	L	L	V	H	V
Row address strobe and bank active	ACTV	H	×	L	L	H	H	V	V	V
Precharge select bank	PRE	H	×	L	L	H	L	V	L	×
Precharge all bank	PALL	H	×	L	L	H	L	×	H	×
Refresh	REF/SELF	H	V	L	L	L	H	×	×	×
Mode register set	MRS	H	×	L	L	L	L	V	V	V



Note: H:  $V_{IH}$ . L:  $V_{IL}$ .  $\times$ :  $V_{IH}$  or  $V_{IL}$ . V: Valid address input

**Ignore command [DESL]:** When this command is set ( $\overline{CS}$  is High), the SDRAM ignore command input at the clock. However, the internal status is held.

**No operation [NOP]:** This command is not an execution command. However, the internal operations continue.

**Burst stop in full-page [BST]:** This command stops a full-page burst operation (burst length = full-page (256; HM52Y64165F, 512; HM52Y64805F, 1024; HM52Y64405F)), and is illegal otherwise. When data input/output is completed for a full page of data, it automatically returns to the start address, and input/output is performed repeatedly.

**Column address strobe and read command [READ]:** This command starts a read operation. In addition, the start address of burst read is determined by the column address (AY0 to AY7; HM52Y64165F, AY0 to AY8; HM52Y64805F, AY0 to AY9; HM52Y64405F) and the bank select address (BS). After the read operation, the output buffer becomes High-Z.

**Read with auto-precharge [READ A]:** This command automatically performs a precharge operation after a burst read with a burst length of 1, 2, 4 or 8. When the burst length is full-page, this command is illegal.

**Column address strobe and write command [WRIT]:** This command starts a write operation. When the burst write mode is selected, the column address (AY0 to AY7; HM52Y64165F, AY0 to AY8; HM52Y64805F, AY0 to AY9; HM52Y64405F) and the bank select address (A12/A13) become the burst write start address. When the single write mode is selected, data is only written to the location specified by the column address (AY0 to AY7; HM52Y64165F, AY0 to AY8; HM52Y64805F, AY0 to AY9; HM52Y64405F) and the bank select address (A12/A13).

**Write with auto-precharge [WRIT A]:** This command automatically performs a precharge operation after a burst write with a length of 1, 2, 4 or 8, or after a single write operation. When the burst length is full-page, this command is illegal.

**Row address strobe and bank activate [ACTV]:** This command activates the bank that is selected by A12/A13 (BS) and determines the row address (AX0 to AX11). When A12 and A13 are Low, bank 0 is activated. When A12 is High and A13 is Low, bank 1 is activated. When A12 is Low and A13 is High, bank 2 is activated. When A12 and A13 are High, bank 3 is activated.

**Precharge selected bank [PRE]:** This command starts precharge operation for the bank selected by A12/A13. If A12 and A13 are Low, bank 0 is selected. If A12 is High and A13 is Low, bank 1 is selected. If A12 is Low and A13 is High, bank 2 is selected. If A12 and A13 are High, bank 3 is selected.

**Precharge all banks [PALL]:** This command starts a precharge operation for all banks.

**Refresh [REF/SELF]:** This command starts the refresh operation. There are two types of refresh operation, the one is auto-refresh, and the other is self-refresh. For details, refer to the CKE truth table section.

**Mode register set [MRS]:** The SDRAM has a mode register that defines how it operates. The mode register is specified by the address pins (A0 to A13) at the mode register set cycle. For details, refer to the mode register configuration. After power on, the contents of the mode register are undefined, execute the mode register set command to set up the mode register.

**DQM Truth Table (HM52Y64165F)**

Command	Symbol	CKE		DQMU	DQML
		n - 1	n		
Upper byte write enable/output enable	ENBU	H	×	L	×
Lower byte write enable/output enable	ENBL	H	×	×	L
Upper byte write inhibit/output disable	MASKU	H	×	H	×
Lower byte write inhibit/output disable	MASKL	H	×	×	H

Note: H:  $V_{IH}$ . L:  $V_{IL}$ . ×:  $V_{IH}$  or  $V_{IL}$ .

Write:  $I_{DID}$  is needed.

Read:  $I_{DOD}$  is needed.

**DQM Truth Table (HM52Y64805F/HM52Y64405F)**

Command	Symbol	CKE		DQM
		n - 1	n	
Write enable/output enable	ENB	H	×	L
Write inhibit/output disable	MASK	H	×	H

Note: H:  $V_{IH}$ . L:  $V_{IL}$ . ×:  $V_{IH}$  or  $V_{IL}$ .

Write:  $I_{DID}$  is needed.

Read:  $I_{DOD}$  is needed.

The SDRAM can mask input/output data by means of DQM, DQMU/DQML.

DQMU masks the upper byte and DQML masks the lower byte. (HM52Y64165F)

During reading, the output buffer is set to Low-Z by setting DQM, DQMU/DQML to Low, enabling data output. On the other hand, when DQM, DQMU/DQML is set to High, the output buffer becomes High-Z, disabling data output.

During writing, data is written by setting DQM, DQMU/DQML to Low. When DQM, DQMU/DQML is set to High, the previous data is held (the new data is not written). Desired data can be masked during burst read or burst write by setting DQMU/DQML. For details, refer to the DQM, DQMU/DQML control section of the SDRAM operating instructions.

**CKE Truth Table**

Current state	Command	CKE						Address
		n - 1	n	$\overline{CS}$	$\overline{RAS}$	$\overline{CAS}$	$\overline{WE}$	
Active	Clock suspend mode entry	H	L	H	×	×	×	×
Any	Clock suspend	L	L	×	×	×	×	×
Clock suspend	Clock suspend mode exit	L	H	×	×	×	×	×
Idle	Auto-refresh command (REF)	H	H	L	L	L	H	×
Idle	Self-refresh entry (SELF)	H	L	L	L	L	H	×
Idle	Power down entry	H	L	L	H	H	H	×
		H	L	H	×	×	×	×

Current state	Command	CKE		$\overline{\text{CS}}$	$\overline{\text{RAS}}$	$\overline{\text{CAS}}$	$\overline{\text{WE}}$	Address
		n - 1	n					
Self refresh	Self refresh exit (SELFX)	L	H	L	H	H	H	×
		L	H	H	×	×	×	×
Power down	Power down exit	L	H	L	H	H	H	×
		L	H	H	×	×	×	×

Note: H:  $V_{IH}$ , L:  $V_{IL}$ , ×:  $V_{IH}$  or  $V_{IL}$ .

**Clock suspend mode entry:** The SDRAM enters clock suspend mode from active mode by setting CKE to Low. The clock suspend mode changes depending on the current status (1 clock before) as shown below.

**ACTIVE clock suspend:** This suspend mode ignores inputs after the next clock by internally maintaining the bank active status.

**READ suspend and READ with Auto-precharge suspend:** The data being output is held (and continues to be output).

**WRITE suspend and WRIT with Auto-precharge suspend:** In this mode, external signals are not accepted. However, the internal state is held.

**Clock suspend:** During clock suspend mode, keep the CKE to Low.

**Clock suspend mode exit:** The SDRAM exits from clock suspend mode by setting CKE to High during the clock suspend state.

**IDLE:** In this state, all banks are not selected, and completed precharge operation.

**Auto-refresh command [REF]:** When this command is input from the IDLE state, the SDRAM starts auto-refresh operation. (The auto-refresh is the same as the CBR refresh of conventional DRAMs.) During the auto-refresh operation, refresh address and bank select address are generated inside the SDRAM. For every auto-refresh cycle, the internal address counter is updated. Accordingly, 4096 times are required to refresh the entire memory. Before executing the auto-refresh command, all the banks must be in the IDLE state. In addition, since the precharge for all banks is automatically performed after auto-refresh, no precharge command is required after auto-refresh.

**Self-refresh entry [SELF]:** When this command is input during the IDLE state, the SDRAM starts self-refresh operation. After the execution of this command, self-refresh continues while CKE is Low. Since self-refresh is performed internally and automatically, external refresh operations are unnecessary.

**Power down mode entry:** When this command is executed during the IDLE state, the SDRAM enters power down mode. In power down mode, power consumption is suppressed by cutting off the initial input circuit.

**Self-refresh exit:** When this command is executed during self-refresh mode, the SDRAM can exit from self-refresh mode. After exiting from self-refresh mode, the SDRAM enters the IDLE state.

**Power down exit:** When this command is executed at the power down mode, the SDRAM can exit from power down mode. After exiting from power down mode, the SDRAM enters the IDLE state.

## Function Truth Table

The following table shows the operations that are performed when each command is issued in each mode of the SDRAM.

The following table assumes that CKE is high.

# HM52Y64165F Series HM52Y64805F Series HM52Y64405F Series

Current state	$\overline{\text{CS}}$	$\overline{\text{RAS}}$	$\overline{\text{CAS}}$	$\overline{\text{WE}}$	Address	Command	Operation
Precharge	H	×	×	×	×	DESL	Enter IDLE after $t_{RP}$
	L	H	H	H	×	NOP	Enter IDLE after $t_{RP}$
	L	H	H	L	×	BST	NOP
	L	H	L	H	BA, CA, A10	READ/READ A	ILLEGAL*4
	L	H	L	L	BA, CA, A10	WRIT/WRIT A	ILLEGAL*4
	L	L	H	H	BA, RA	ACTV	ILLEGAL*4
	L	L	H	L	BA, A10	PRE, PALL	NOP*6
	L	L	L	H	×	REF, SELF	ILLEGAL
	L	L	L	L	MODE	MRS	ILLEGAL
Idle	H	×	×	×	×	DESL	NOP
	L	H	H	H	×	NOP	NOP
	L	H	H	L	×	BST	NOP
	L	H	L	H	BA, CA, A10	READ/READ A	ILLEGAL*5
	L	H	L	L	BA, CA, A10	WRIT/WRIT A	ILLEGAL*5
	L	L	H	H	BA, RA	ACTV	Bank and row active
	L	L	H	L	BA, A10	PRE, PALL	NOP
	L	L	L	H	×	REF, SELF	Refresh
	L	L	L	L	MODE	MRS	Mode register set
Row active	H	×	×	×	×	DESL	NOP
	L	H	H	H	×	NOP	NOP
	L	H	H	L	×	BST	NOP
	L	H	L	H	BA, CA, A10	READ/READ A	Begin read
	L	H	L	L	BA, CA, A10	WRIT/WRIT A	Begin write
	L	L	H	H	BA, RA	ACTV	Other bank active ILLEGAL on same bank*3
	L	L	H	L	BA, A10	PRE, PALL	Precharge
	L	L	L	H	×	REF, SELF	ILLEGAL
	L	L	L	L	MODE	MRS	ILLEGAL
Read	H	×	×	×	×	DESL	Continue burst to end
	L	H	H	H	×	NOP	Continue burst to end
	L	H	H	L	×	BST	Burst stop to full page
	L	H	L	H	BA, CA, A10	READ/READ A	Continue burst read to $\overline{\text{CAS}}$ latency and New read
	L	H	L	L	BA, CA, A10	WRIT/WRIT A	Term burst read/start write
	L	L	H	H	BA, RA	ACTV	Other bank active ILLEGAL on same bank*3
	L	L	H	L	BA, A10	PRE, PALL	Term burst read and Precharge
	L	L	L	H	×	REF, SELF	ILLEGAL
	L	L	L	L	MODE	MRS	ILLEGAL

# HM52Y64165F Series HM52Y64805F Series HM52Y64405F Series

Current state	$\overline{\text{CS}}$	$\overline{\text{RAS}}$	$\overline{\text{CAS}}$	$\overline{\text{WE}}$	Address	Command	Operation
Read with auto-precharge	H	x	x	x	x	DESL	Continue burst to end and precharge
	L	H	H	H	x	NOP	Continue burst to end and precharge
	L	H	H	L	x	BST	ILLEGAL
	L	H	L	H	BA, CA, A10	READ/READ A	ILLEGAL <sup>*4</sup>
	L	H	L	L	BA, CA, A10	WRIT/WRIT A	ILLEGAL <sup>*4</sup>
	L	L	H	H	BA, RA	ACTV	Other bank active ILLEGAL on same bank <sup>*3</sup>
	L	L	H	L	BA, A10	PRE, PALL	ILLEGAL <sup>*4</sup>
	L	L	L	H	x	REF, SELF	ILLEGAL
	L	L	L	L	MODE	MRS	ILLEGAL
Write	H	x	x	x	x	DESL	Continue burst to end
	L	H	H	H	x	NOP	Continue burst to end
	L	H	H	L	x	BST	Burst stop on full page
	L	H	L	H	BA, CA, A10	READ/READ A	Term burst and New read
	L	H	L	L	BA, CA, A10	WRIT/WRIT A	Term burst and New write
	L	L	H	H	BA, RA	ACTV	Other bank active ILLEGAL on same bank <sup>*3</sup>
	L	L	H	L	BA, A10	PRE, PALL	Term burst write and Precharge <sup>*2</sup>
	L	L	L	H	x	REF, SELF	ILLEGAL
	L	L	L	L	MODE	MRS	ILLEGAL
Write with auto-precharge	H	x	x	x	x	DESL	Continue burst to end and precharge
	L	H	H	H	x	NOP	Continue burst to end and precharge
	L	H	H	L	x	BST	ILLEGAL
	L	H	L	H	BA, CA, A10	READ/READ A	ILLEGAL <sup>*4</sup>
	L	H	L	L	BA, CA, A10	WRIT/WRIT A	ILLEGAL <sup>*4</sup>
	L	L	H	H	BA, RA	ACTV	Other bank active ILLEGAL on same bank <sup>*3</sup>
	L	L	H	L	BA, A10	PRE, PALL	ILLEGAL <sup>*4</sup>
	L	L	L	H	x	REF, SELF	ILLEGAL
	L	L	L	L	MODE	MRS	ILLEGAL
Refresh (auto-refresh)	H	x	x	x	x	DESL	Enter IDLE after $t_{RC}$
	L	H	H	H	x	NOP	Enter IDLE after $t_{RC}$
	L	H	H	L	x	BST	Enter IDLE after $t_{RC}$
	L	H	L	H	BA, CA, A10	READ/READ A	ILLEGAL <sup>*5</sup>
	L	H	L	L	BA, CA, A10	WRIT/WRIT A	ILLEGAL <sup>*5</sup>
	L	L	H	H	BA, RA	ACTV	ILLEGAL <sup>*5</sup>
	L	L	H	L	BA, A10	PRE, PALL	ILLEGAL <sup>*5</sup>
	L	L	L	H	x	REF, SELF	ILLEGAL
	L	L	L	L	MODE	MRS	ILLEGAL

Notes: 1. H:  $V_{IH}$ . L:  $V_{IL}$ .  $\times$ :  $V_{IH}$  or  $V_{IL}$ . The other combinations are inhibit.

2. An interval of  $t_{DPL}$  is required between the final valid data input and the precharge command.
3. If  $t_{RRD}$  is not satisfied, this operation is illegal.
4. Illegal for same bank, except for another bank.
5. Illegal for all banks.
6. NOP for same bank, except for another bank.

### **From PRECHARGE state, command operation**

**To [DESL], [NOP] or [BST]:** When these commands are executed, the SDRAM enters the IDLE state after  $t_{RP}$  has elapsed from the completion of precharge.

### **From IDLE state, command operation**

**To [DESL], [NOP], [BST], [PRE] or [PALL]:** These commands result in no operation.

**To [ACTV]:** The bank specified by the address pins and the ROW address is activated.

**To [REF], [SELF]:** The SDRAM enters refresh mode (auto-refresh or self-refresh).

**To [MRS]:** The SDRAM enters the mode register set cycle.

### **From ROW ACTIVE state, command operation**

**To [DESL], [NOP] or [BST]:** These commands result in no operation.

**To [READ], [READ A]:** A read operation starts. (However, an interval of  $t_{RCD}$  is required.)

**To [WRIT], [WRIT A]:** A write operation starts. (However, an interval of  $t_{RCD}$  is required.)

**To [ACTV]:** This command makes the other bank active. (However, an interval of  $t_{RRD}$  is required.) Attempting to make the currently active bank active results in an illegal command.

**To [PRE], [PALL]:** These commands set the SDRAM to precharge mode. (However, an interval of  $t_{RAS}$  is required.)

### **From READ state, command operation**

**To [DESL], [NOP]:** These commands continue read operations until the burst operation is completed.

**To [BST]:** This command stops a full-page burst.

**To [READ], [READ A]:** Data output by the previous read command continues to be output. After  $\overline{\text{CAS}}$  latency, the data output resulting from the next command will start.

**To [WRIT], [WRIT A]:** These commands stop a burst read, and start a write cycle.

**To [ACTV]:** This command makes other banks bank active. (However, an interval of  $t_{RRD}$  is required.) Attempting to make the currently active bank active results in an illegal command.

**To [PRE], [PALL]:** These commands stop a burst read, and the SDRAM enters precharge mode.

### **From READ with AUTO-PRECHARGE state, command operation**

**To [DESL], [NOP]:** These commands continue read operations until the burst operation is completed, and the SDRAM then enters precharge mode.

**To [ACTV]:** This command makes other banks bank active. (However, an interval of  $t_{RRD}$  is required.) Attempting to make the currently active bank active results in an illegal command.

## **From WRITE state, command operation**

**To [DESL], [NOP]:** These commands continue write operations until the burst operation is completed.

**To [BST]:** This command stops a full-page burst.

**To [READ], [READ A]:** These commands stop a burst and start a read cycle.

**To [WRIT], [WRIT A]:** These commands stop a burst and start the next write cycle.

**To [ACTV]:** This command makes the other bank active. (However, an interval of  $t_{RRD}$  is required.) Attempting to make the currently active bank active results in an illegal command.

**To [PRE], [PALL]:** These commands stop burst write and the SDRAM then enters precharge mode.

## **From WRITE with AUTO-PRECHARGE state, command operation**

**To [DESL], [NOP]:** These commands continue write operations until the burst is completed, and the synchronous DRAM enters precharge mode.

**To [ACTV]:** This command makes the other bank active. (However, an interval of  $t_{RRD}$  is required.) Attempting to make the currently active bank active results in an illegal command.

## **From REFRESH state, command operation**

**To [DESL], [NOP], [BST]:** After an auto-refresh cycle (after  $t_{RC}$ ), the SDRAM automatically enters the IDLE state.

### Simplified State Diagram

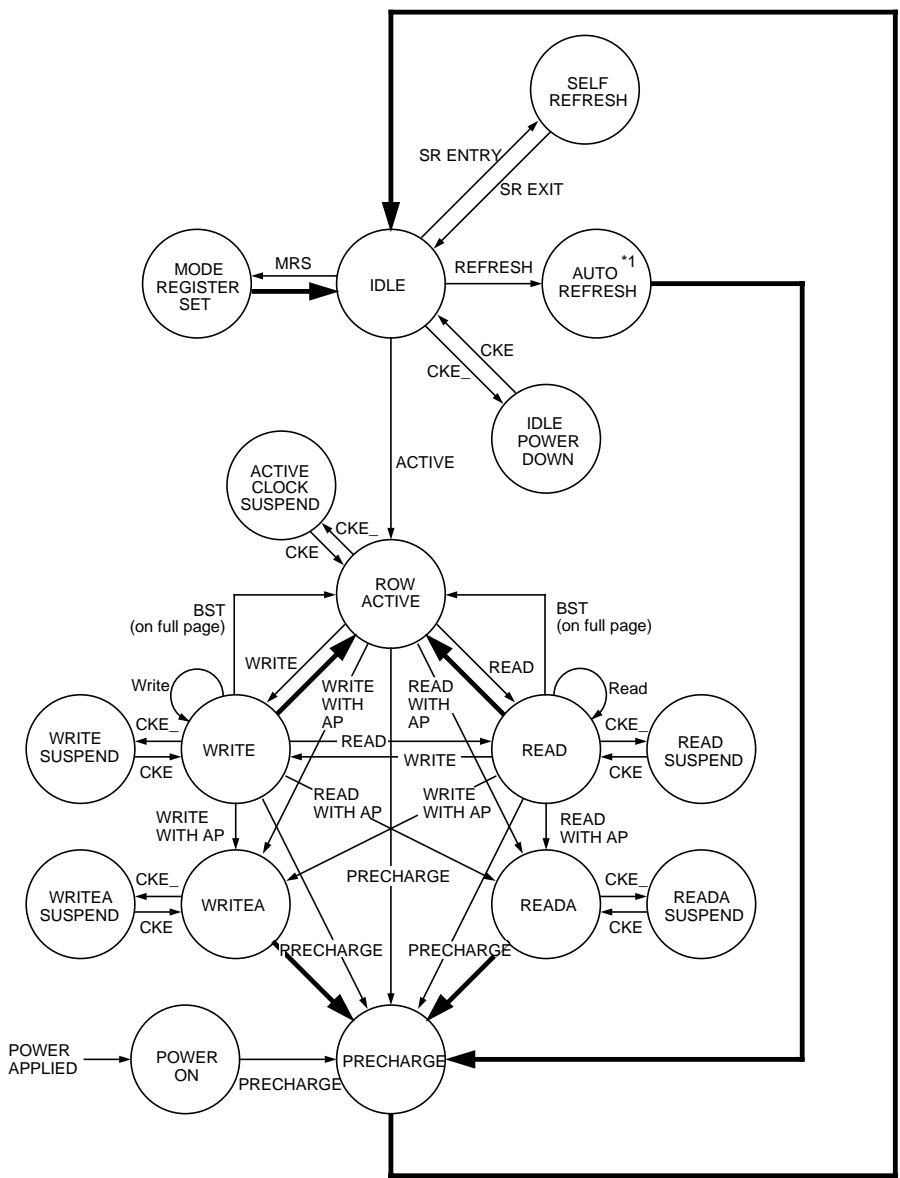

Automatic transition after completion of command.  
 Transition resulting from command input.

Note: 1. After the auto-refresh operation, precharge operation is performed automatically and enter the IDLE state.

### Mode Register Configuration

The mode register is set by the input to the address pins (A0 to A13) during mode register set cycles. The mode register consists of five sections, each of which is assigned to address pins.

**A13, A12, A11, A10, A9 A8: (OPCODE):** The SDRAM has two types of write modes. One is the burst write mode, and the other is the single write mode. These bits specify write mode.



**Burst read and burst write:** Burst write is performed for the specified burst length starting from the column address specified in the write cycle.

**Burst read and single write:** Data is only written to the column address specified during the write cycle, regardless of the burst length.

**A7:** Keep this bit Low at the mode register set cycle. If this pin is high, the vendor test mode is set.

**A6, A5, A4: (LMODE):** These pins specify the  $\overline{\text{CAS}}$  latency.

**A3: (BT):** A burst type is specified. When full-page burst is performed, only "sequential" can be selected.

**A2, A1, A0: (BL):** These pins specify the burst length.

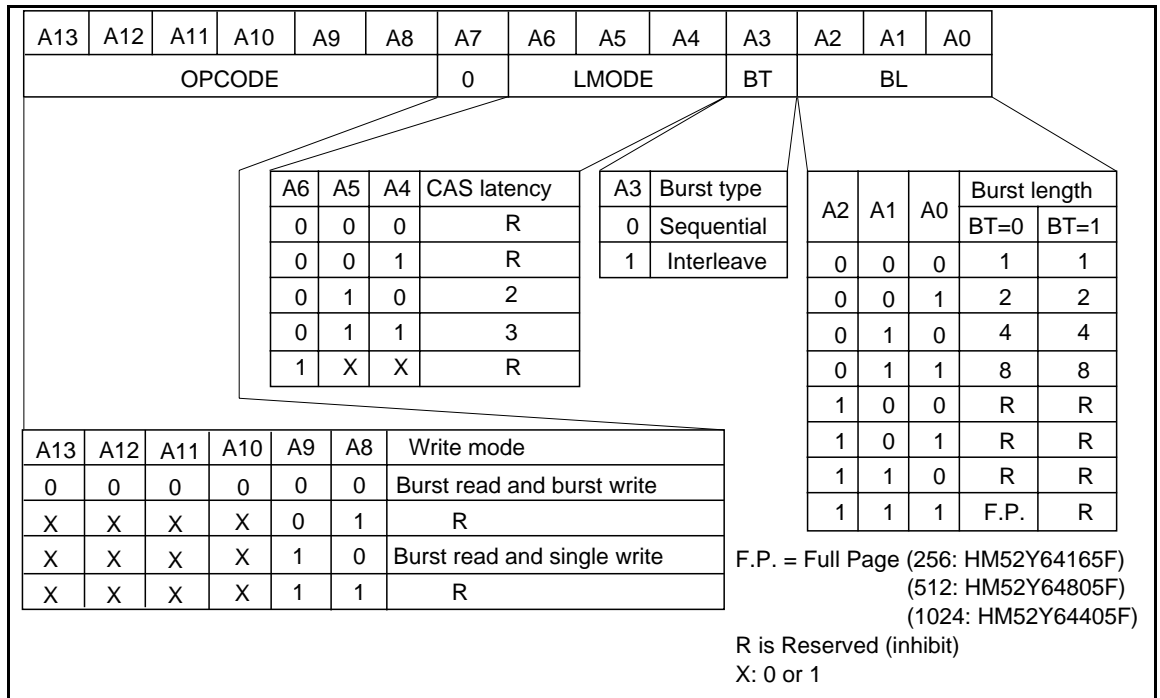

## Burst Sequence

Burst length = 2

Starting Ad.	Addressing(decimal)	
A0	Sequential	Interleave
0	0, 1,	0, 1,
1	1, 0,	1, 0,

Burst length = 4

Starting Ad.		Addressing(decimal)	
A1	A0	Sequential	Interleave
0	0	0, 1, 2, 3,	0, 1, 2, 3,
0	1	1, 2, 3, 0,	1, 0, 3, 2,
1	0	2, 3, 0, 1,	2, 3, 0, 1,
1	1	3, 0, 1, 2,	3, 2, 1, 0,

Burst length = 8

Starting Ad.			Addressing(decimal)	
A2	A1	A0	Sequential	Interleave
0	0	0	0, 1, 2, 3, 4, 5, 6, 7,	0, 1, 2, 3, 4, 5, 6, 7,
0	0	1	1, 2, 3, 4, 5, 6, 7, 0,	1, 0, 3, 2, 5, 4, 7, 6,
0	1	0	2, 3, 4, 5, 6, 7, 0, 1,	2, 3, 0, 1, 6, 7, 4, 5,
0	1	1	3, 4, 5, 6, 7, 0, 1, 2,	3, 2, 1, 0, 7, 6, 5, 4,
1	0	0	4, 5, 6, 7, 0, 1, 2, 3,	4, 5, 6, 7, 0, 1, 2, 3,
1	0	1	5, 6, 7, 0, 1, 2, 3, 4,	5, 4, 7, 6, 1, 0, 3, 2,
1	1	0	6, 7, 0, 1, 2, 3, 4, 5,	6, 7, 4, 5, 2, 3, 0, 1,
1	1	1	7, 0, 1, 2, 3, 4, 5, 6,	7, 6, 5, 4, 3, 2, 1, 0,

## Operation of the SDRAM

### Read/Write Operations

**Bank active:** Before executing a read or write operation, the corresponding bank and the row address must be activated by the bank active (ACTV) command. Bank 0, bank 1, bank 2 or bank 3 is activated according to the status of the A12/A13 pin, and the row address (AX0 to AX11) is activated by the A0 to A11 pins at the bank active command cycle. An interval of  $t_{RCD}$  is required between the bank active command input and the following read/write command input.

**Read operation:** A read operation starts when a read command is input. Output buffer becomes Low-Z in the ( $\overline{CAS}$  Latency - 1) cycle after read command set. HM52Y64165F, HM52Y64805F series, HM52Y64405F can perform a burst read operation.

The burst length can be set to 1, 2, 4, 8 or full-page (256; HM52Y64165F, 512; HM52Y64805F, 1024; HM52Y64405F). The start address for a burst read is specified by the column address (AY0 to AY7; HM52Y64165F, AY0 to AY8; HM52Y64805F, AY0 to AY9; HM52Y64405F) and the bank select address (A12/A13) at the read command set cycle. In a read operation, data output starts after the number of clocks specified by the  $\overline{CAS}$  Latency. The  $\overline{CAS}$  Latency can be set to 2 or 3.

When the burst length is 1, 2, 4, 8, the Dout buffer automatically becomes High-Z at the next clock after the successive burst-length data has been output.

The  $\overline{CAS}$  latency and burst length must be specified at the mode register.

## CAS Latency

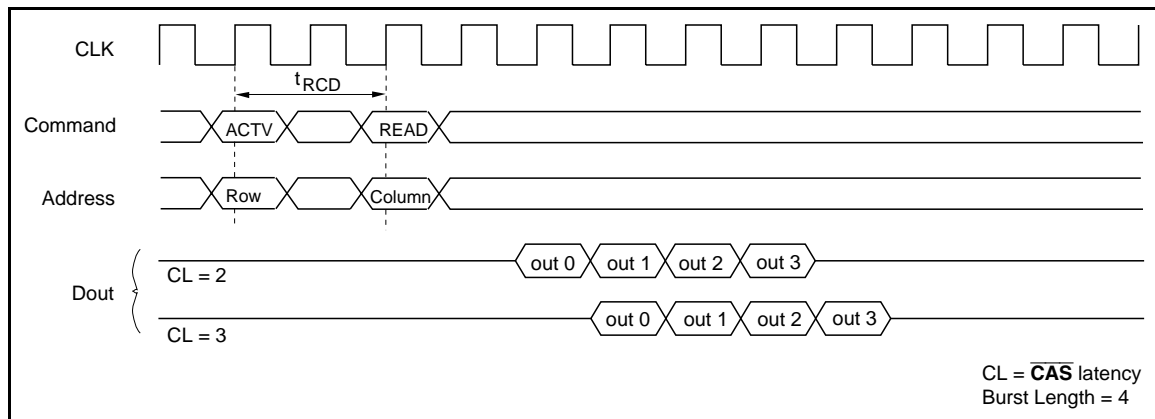

## Burst Length

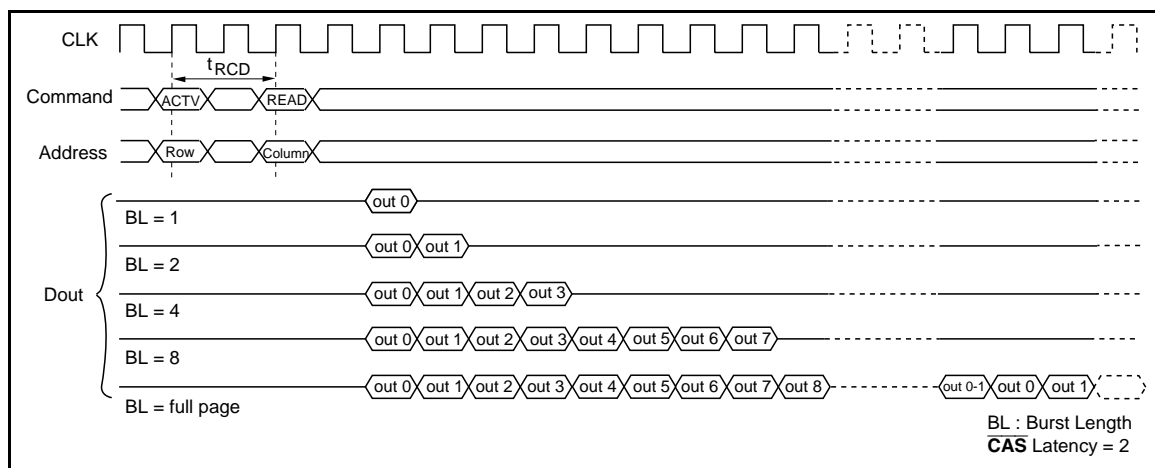

**Write operation:** Burst write or single write mode is selected by the OPCODE (A13, A12, A11, A10, A9, A8) of the mode register.

**1. Burst write:** A burst write operation is enabled by setting OPCODE (A9, A8) to (0, 0). A burst write starts in the same clock as a write command set. (The latency of data input is 0 clock.) The burst length can be set to 1, 2, 4, 8, and full-page, like burst read operations. The write start address is specified by the column address (AY0 to AY7; HM52Y64165F, AY0 to AY8; HM52Y64805F, AY0 to AY9; HM52Y64405F) and the bank select address (A12/A13) at the write command set cycle.

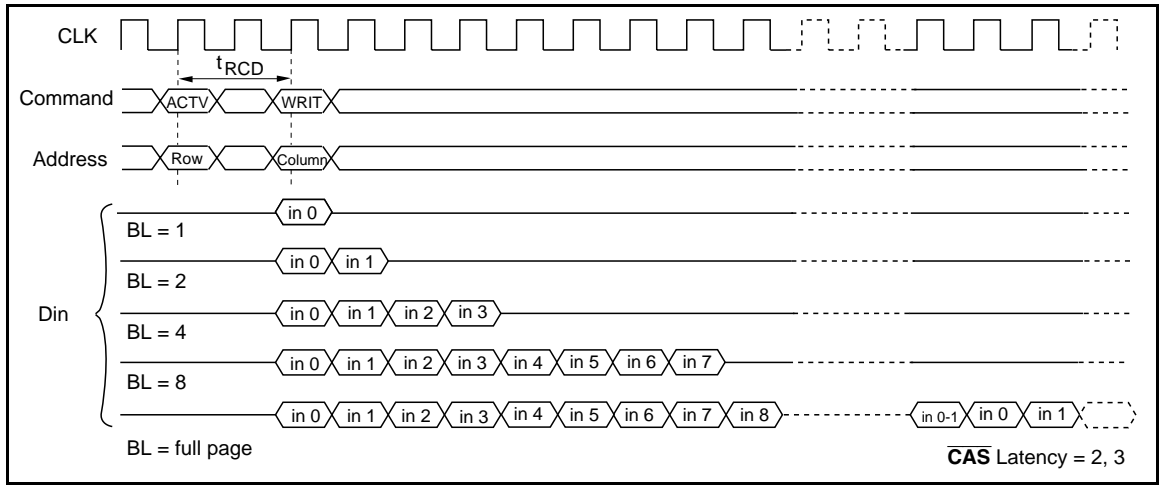

**2. Single write:** A single write operation is enabled by setting OPCODE (A9, A8) to (1, 0). In a single write operation, data is only written to the column address (AY0 to AY7; HM52Y64165F, AY0 to AY8; HM52Y64805F, AY0 to AY9; HM52Y64405F) and the bank select address (A12/A13) specified by the write command set cycle without regard to the burst length setting. (The latency of data input is 0 clock).

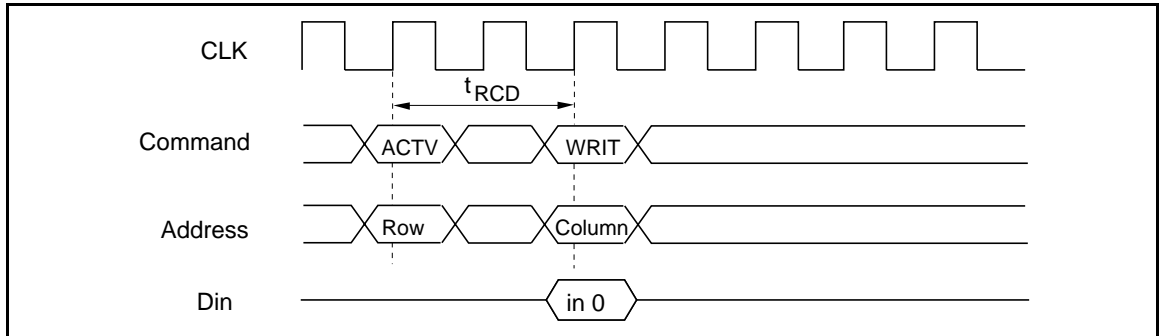

### Auto Precharge

**Read with auto-precharge:** In this operation, since precharge is automatically performed after completing a read operation, a precharge command need not be executed after each read operation. The command executed for the same bank after the execution of this command must be the bank active (ACTV) command. In addition, an interval defined by  $I_{APR}$  is required before execution of the next command.

CAS latency	Precharge start cycle
3	2 cycle before the final data is output
2	1 cycle before the final data is output

**Burst Read (Burst Length = 4)**

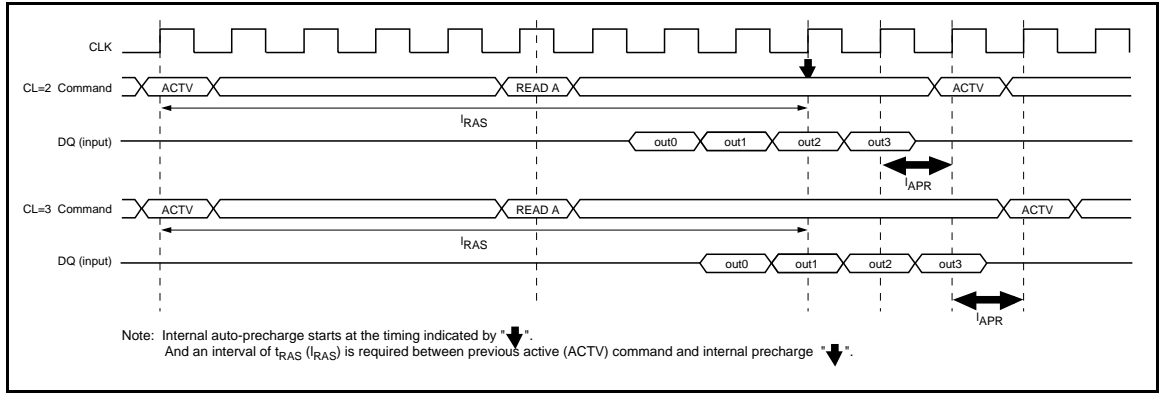

**Write with auto-precharge:** In this operation, since precharge is automatically performed after completing a burst write or single write operation, a precharge command need not be executed after each write operation. The command executed for the same bank after the execution of this command must be the bank active (ACTV) command. In addition, an interval of  $t_{APW}$  is required between the final valid data input and input of next command.

**Burst Write (Burst Length = 4)**

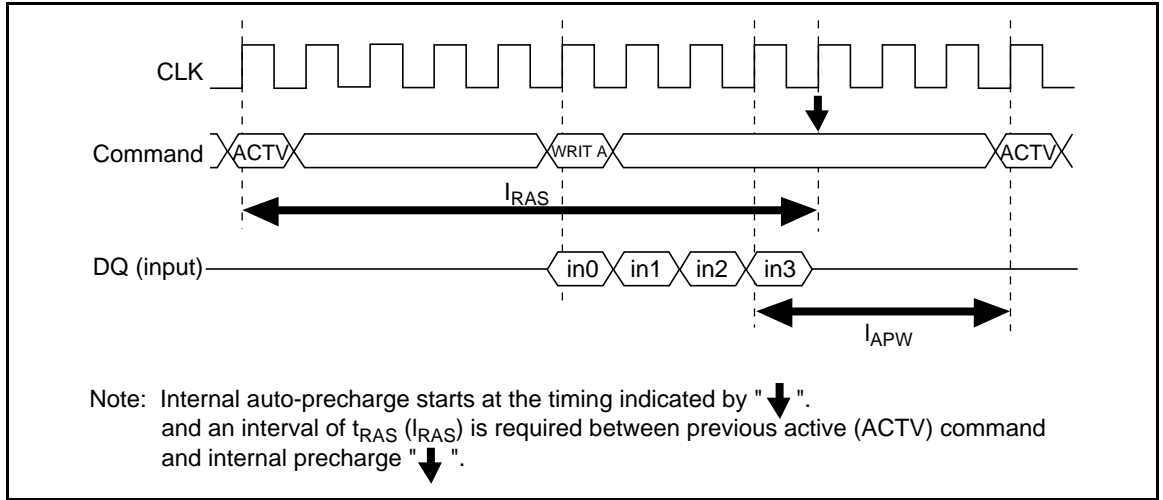

**Single Write**

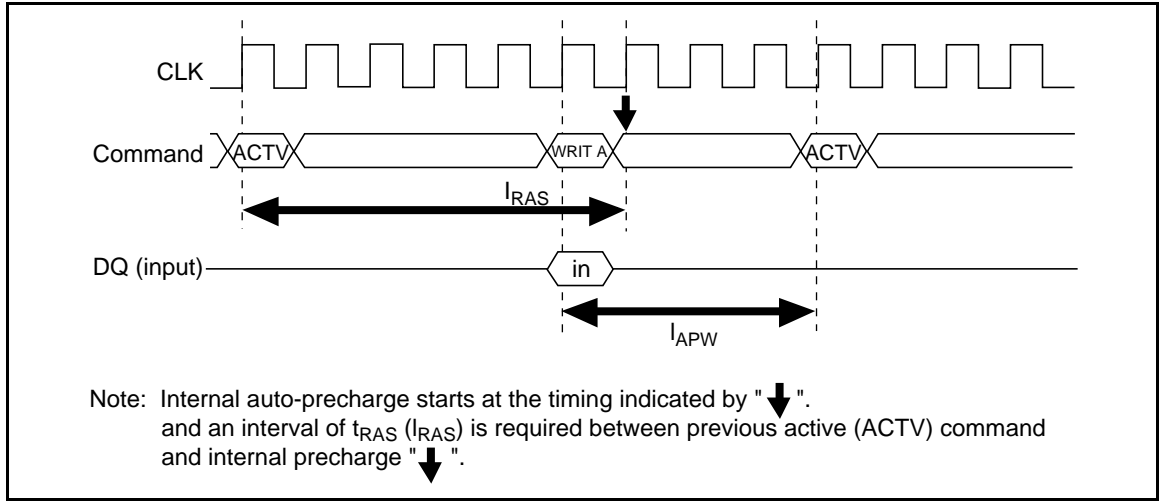

**Full-page Burst Stop**

**Burst stop command during burst read:** The burst stop (BST) command is used to stop data output during a full-page burst. The BST command sets the output buffer to High-Z and stops the full-page burst read. The timing from command input to the last data changes depending on the  $\overline{CAS}$  latency setting. In addition, the BST command is valid only during full-page burst mode, and is illegal with burst lengths 1, 2, 4 and 8.

$\overline{CAS}$ latency	BST to valid data	BST to high impedance
2	1	2
3	2	3

**$\overline{CAS}$  Latency = 2, Burst Length = full page**

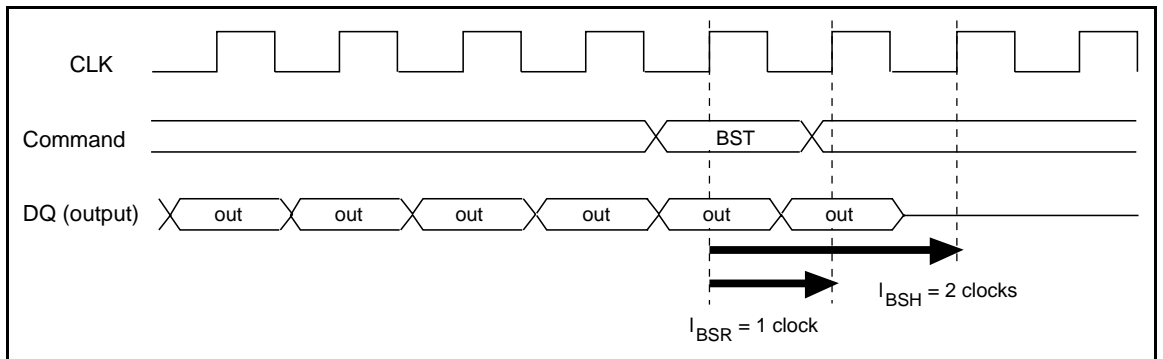

**CAS Latency = 3, Burst Length = full page**

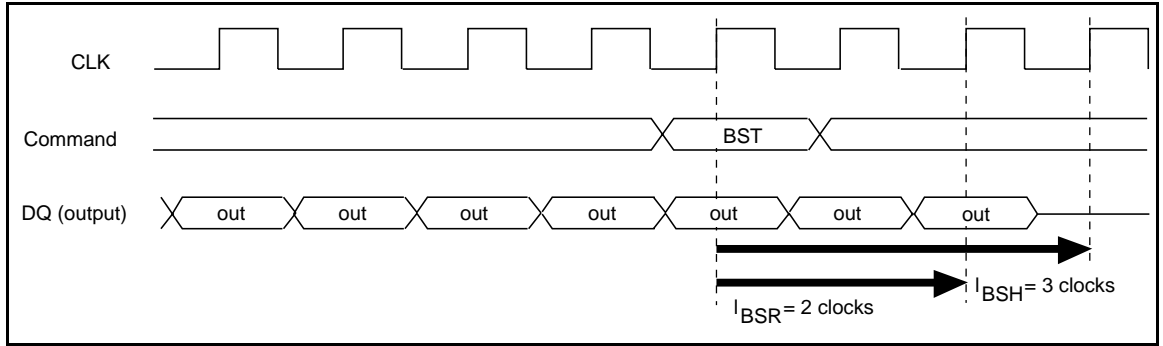

**Burst stop command at burst write:** The burst stop command (BST command) is used to stop data input during a full-page burst write. No data is written in the same clock as the BST command, and in subsequent clocks. In addition, the BST command is only valid during full-page burst mode, and is illegal with burst lengths of 1, 2, 4 and 8. And an interval of  $t_{DPL}$  is required between last data-in and the next precharge command.

**Burst Length = full page**

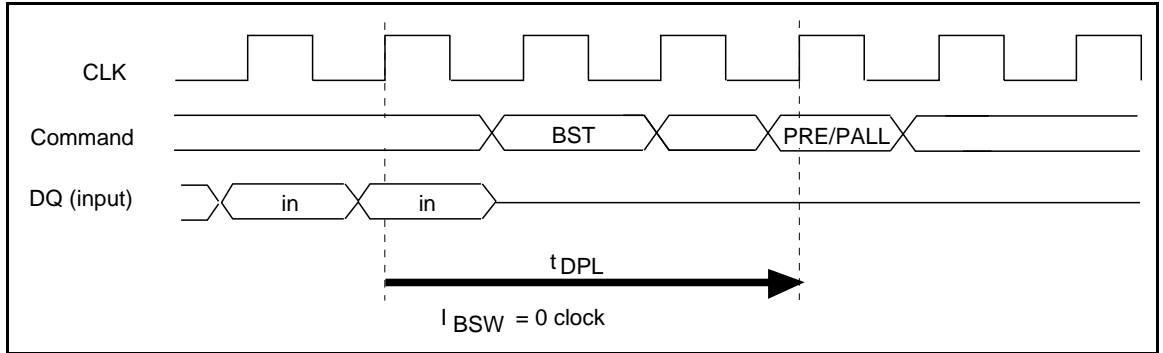

**Command Intervals**

**Read command to Read command interval:**

**1. Same bank, same ROW address:** When another read command is executed at the same ROW address of the same bank as the preceding read command execution, the second read can be performed after an interval of no less than 1 clock. Even when the first command is a burst read that is not yet finished, the data read by the second command will be valid.

**READ to READ Command Interval (same ROW address in same bank)**

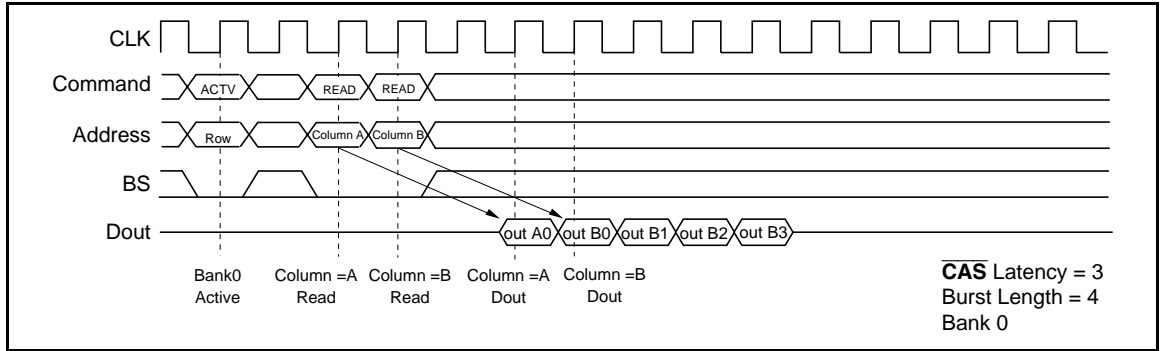

**2. Same bank, different ROW address:** When the ROW address changes on same bank, consecutive read commands cannot be executed; it is necessary to separate the two read commands with a precharge command and a bank-active command.

**3. Different bank:** When the bank changes, the second read can be performed after an interval of no less than 1 clock, provided that the other bank is in the bank-active state. Even when the first command is a burst read that is not yet finished, the data read by the second command will be valid.

**READ to READ Command Interval (different bank)**

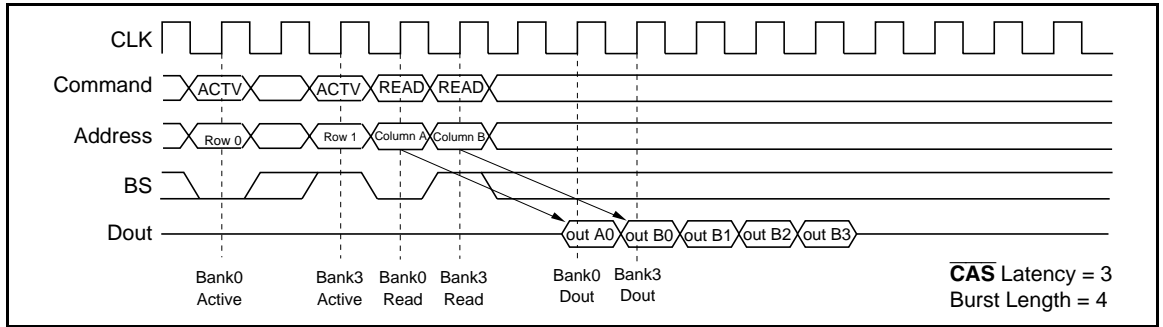

**Write command to Write command interval:**

**1. Same bank, same ROW address:** When another write command is executed at the same ROW address of the same bank as the preceding write command, the second write can be performed after an interval of no less than 1 clock. In the case of burst writes, the second write command has priority.



**WRITE to WRITE Command Interval (same ROW address in same bank)**

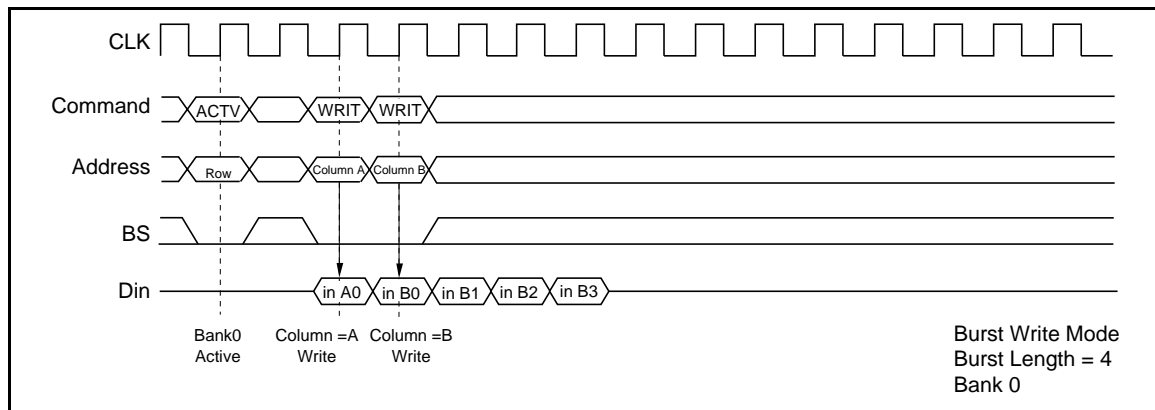

**2. Same bank, different ROW address:** When the ROW address changes, consecutive write commands cannot be executed; it is necessary to separate the two write commands with a precharge command and a bank-active command.

**3. Different bank:** When the bank changes, the second write can be performed after an interval of no less than 1 clock, provided that the other bank is in the bank-active state. In the case of burst write, the second write command has priority.

**WRITE to WRITE Command Interval (different bank)**

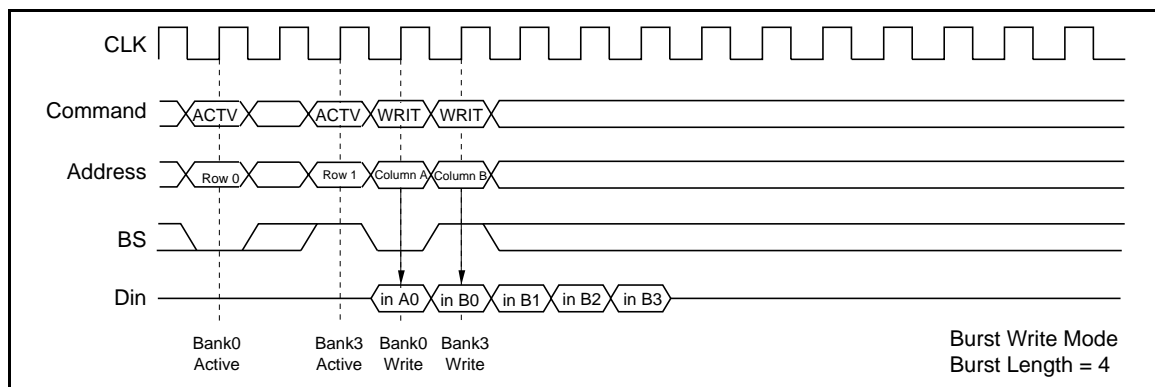

**Read command to Write command interval:**

**1. Same bank, same ROW address:** When the write command is executed at the same ROW address of the same bank as the preceding read command, the write command can be performed after an interval of no less than 1 clock. However, DQM, DQMU/DQML must be set High so that the output buffer becomes High-Z before data input.

**READ to WRITE Command Interval (1)**

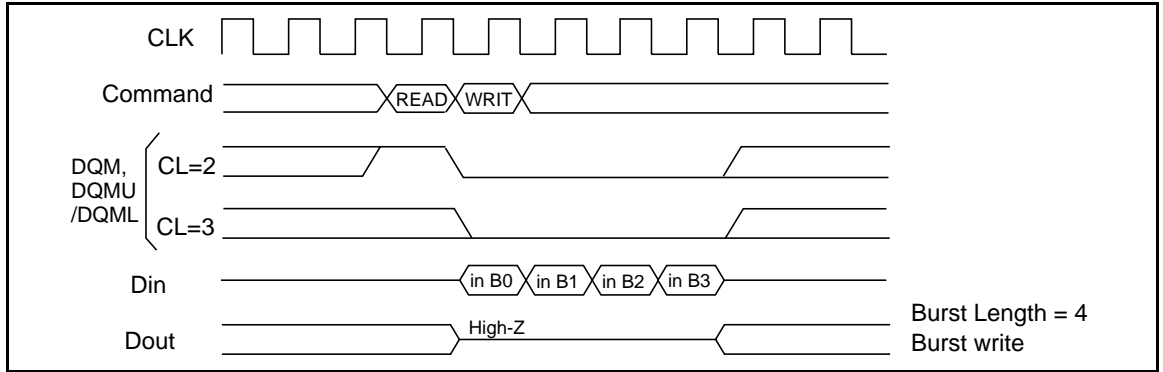

**READ to WRITE Command Interval (2)**

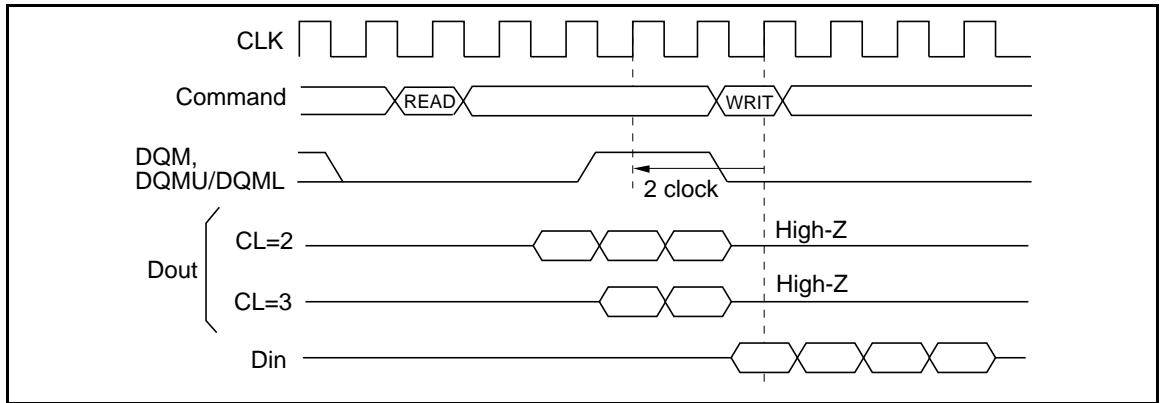

**2. Same bank, different ROW address:** When the ROW address changes, consecutive write commands cannot be executed; it is necessary to separate the two commands with a precharge command and a bank-active command.

**3. Different bank:** When the bank changes, the write command can be performed after an interval of no less than 1 clock, provided that the other bank is in the bank-active state. However, DQM, DQMU/DQML must be set High so that the output buffer becomes High-Z before data input.

**Write command to Read command interval:**

**1. Same bank, same ROW address:** When the read command is executed at the same ROW address of the same bank as the preceding write command, the read command can be performed after an interval of no less than 1 clock. However, in the case of a burst write, data will continue to be written until one cycle before the read command is executed.

### WRITE to READ Command Interval (1)

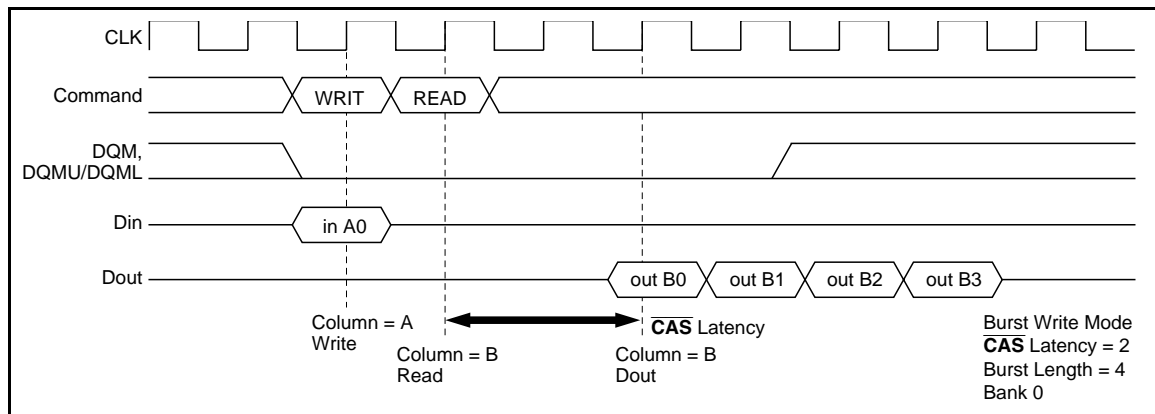

### WRITE to READ Command Interval (2)

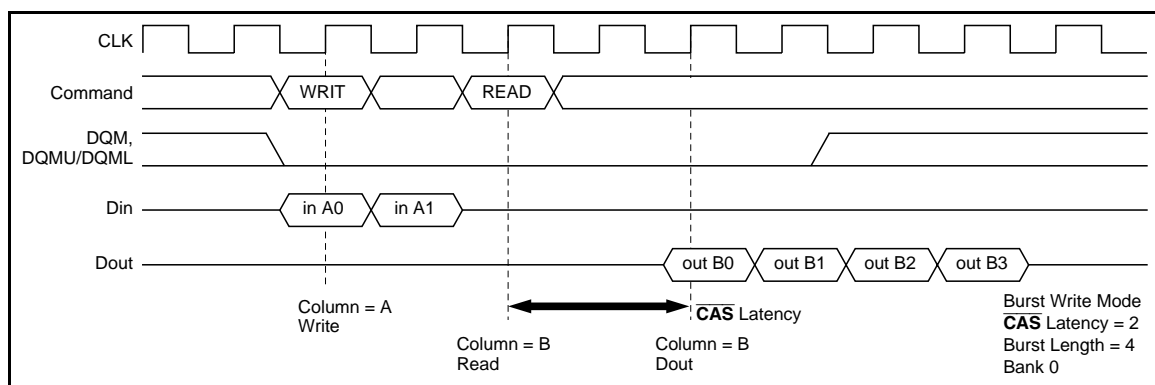

**2. Same bank, different ROW address:** When the ROW address changes, consecutive read commands cannot be executed; it is necessary to separate the two commands with a precharge command and a bank-active command.

**3. Different bank:** When the bank changes, the read command can be performed after an interval of no less than 1 clock, provided that the other bank is in the bank-active state. However, in the case of a burst write, data will continue to be written until one clock before the read command is executed (as in the case of the same bank and the same address).

### Read with auto precharge to Read command interval

**1. Different bank:** When some banks are in the active state, the second read command (another bank) is executed. Even when the first read with auto-precharge is a burst read that is not yet finished, the data read by the second command is valid. The internal auto-precharge of one bank starts at the next clock of the second command.

### Read with Auto Precharge to Read Command Interval (Different bank)

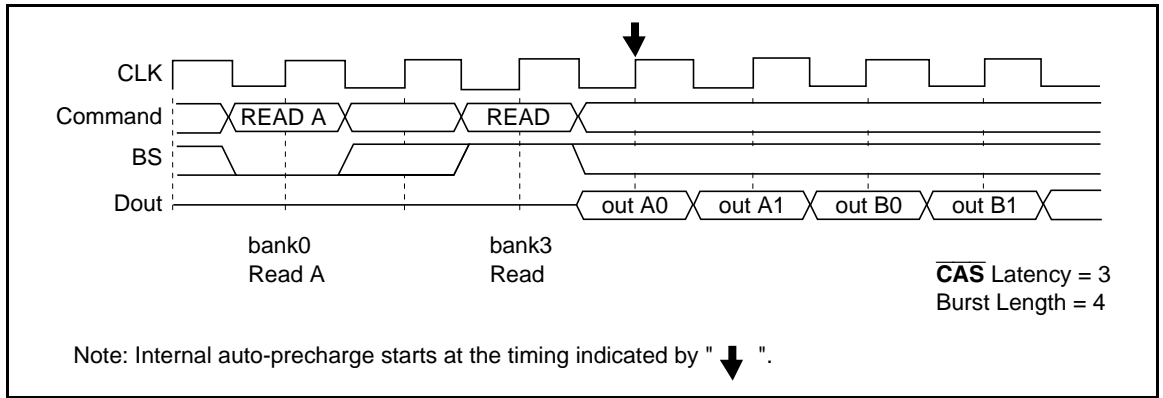

2. **Same bank:** The consecutive read command (the same bank) is illegal.

**Write with auto precharge to Write command interval**

1. **Different bank:** When some banks are in the active state, the second write command (another bank) is executed. In the case of burst writes, the second write command has priority. The internal auto-precharge of one bank starts at the next clock of the second command.

**Write with Auto Precharge to Write Command Interval (Different bank)**

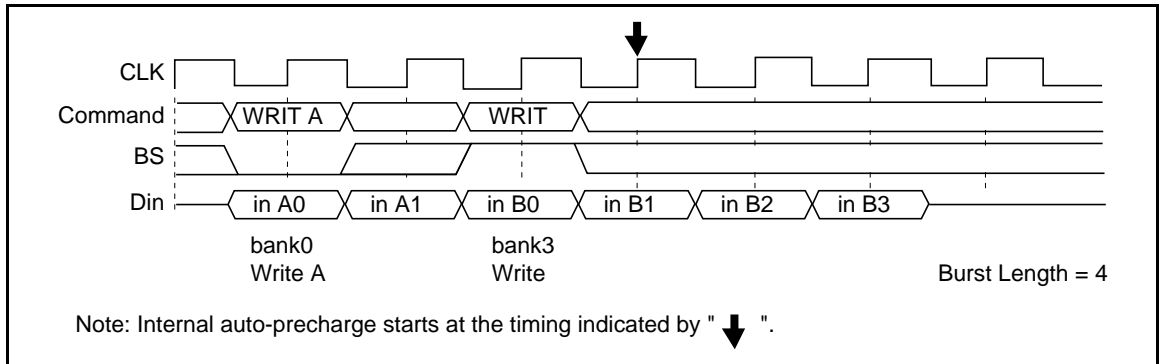

2. **Same bank:** The consecutive write command (the same bank) is illegal.

**Read with auto precharge to Write command interval**

1. **Different bank:** When some banks are in the active state, the second write command (another bank) is executed. However, DQM, DQMU/DQML must be set High so that the output buffer becomes High-Z before data input. The internal auto-precharge of one bank starts at the next clock of the second command.

**Read with Auto Precharge to Write Command Interval (Different bank)**

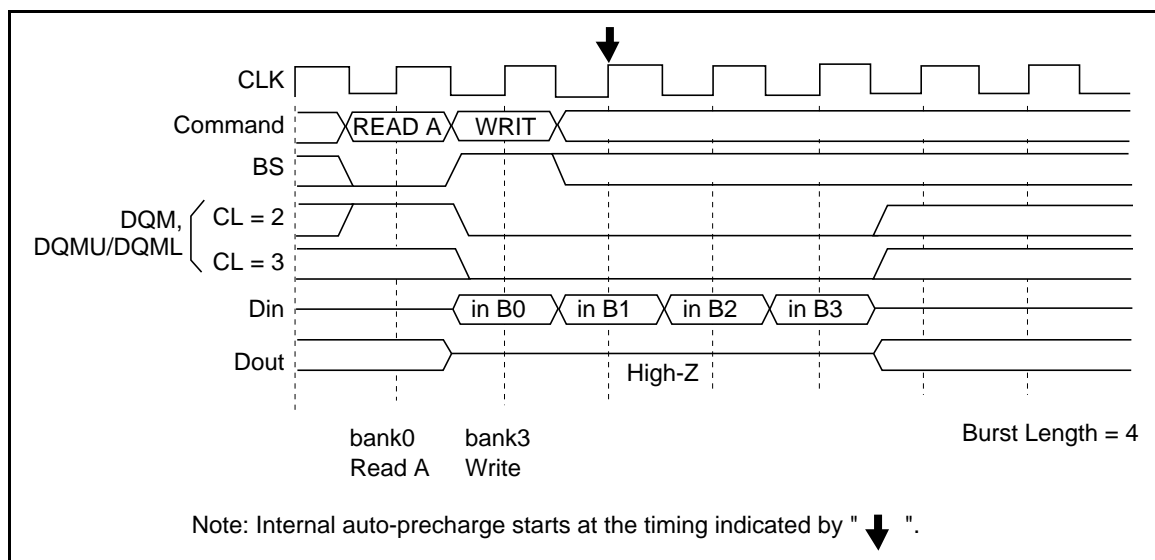

**2. Same bank:** The consecutive write command from read with auto precharge (the same bank) is illegal. It is necessary to separate the two commands with a bank active command.

**Write with auto precharge to Read command interval**

**1. Different bank:** When some banks are in the active state, the second read command (another bank) is executed. However, in case of a burst write, data will continue to be written until one clock before the read command is executed. The internal auto-precharge of one bank starts at the next clock of the second command.

**Write with Auto Precharge to Read Command Interval (Different bank)**

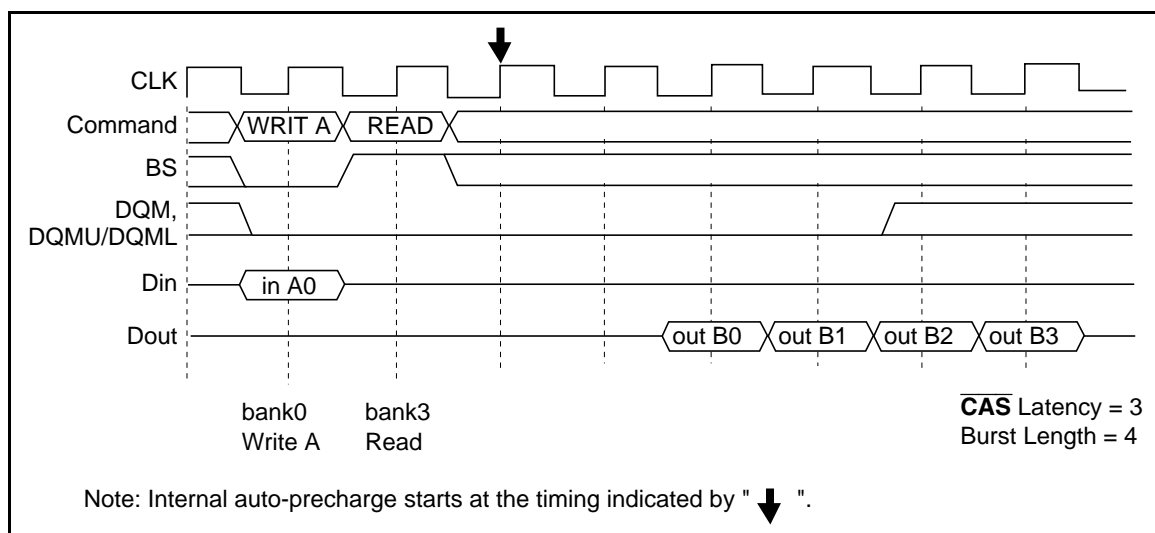

**Same bank:** The consecutive read command from write with auto precharge (the same bank) is illegal. It is necessary to separate the two commands with a bank active command.

**Read command to Precharge command interval (same bank):**

When the precharge command is executed for the same bank as the read command that preceded it, the minimum interval between the two commands is one clock. However, since the output buffer then becomes High-Z after the clocks defined by  $t_{HZP}$ , there is a case of interruption to burst read data output will be interrupted, if the precharge command is input during burst read. To read all data by burst read, the clocks defined by  $t_{EP}$  must be assured as an interval from the final data output to precharge command execution.

**READ to PRECHARGE Command Interval (same bank): To output all data**

**CAS Latency = 2, Burst Length = 4**

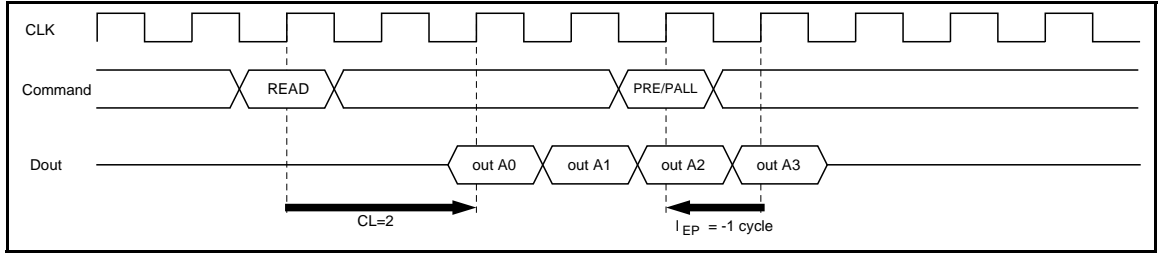

**CAS Latency = 3, Burst Length = 4**

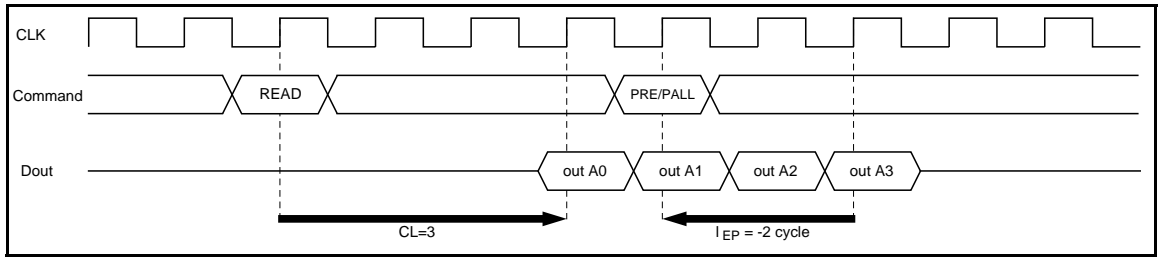

**READ to PRECHARGE Command Interval (same bank): To stop output data**

**CAS Latency = 2, Burst Length = 1, 2, 4, 8, full page burst**

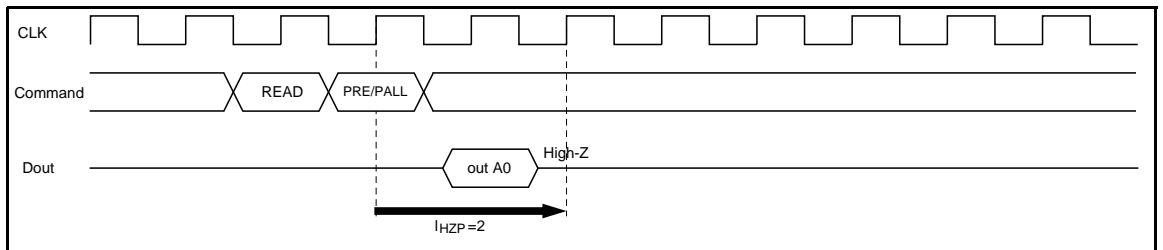

**CAS Latency = 3, Burst Length = 1, 2, 4, 8, full page burst**

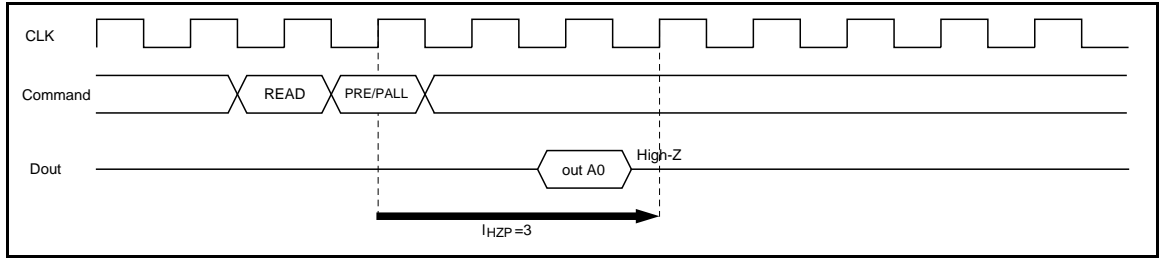

**Write command to Precharge command interval (same bank):** When the precharge command is executed for the same bank as the write command that preceded it, the minimum interval between the two commands is 1 clock. However, if the burst write operation is unfinished, the input data must be masked by means of DQM, DQMU/DQML for assurance of the clock defined by  $t_{DPL}$ .

**WRITE to PRECHARGE Command Interval (same bank)**

**Burst Length = 4 (To stop write operation)**

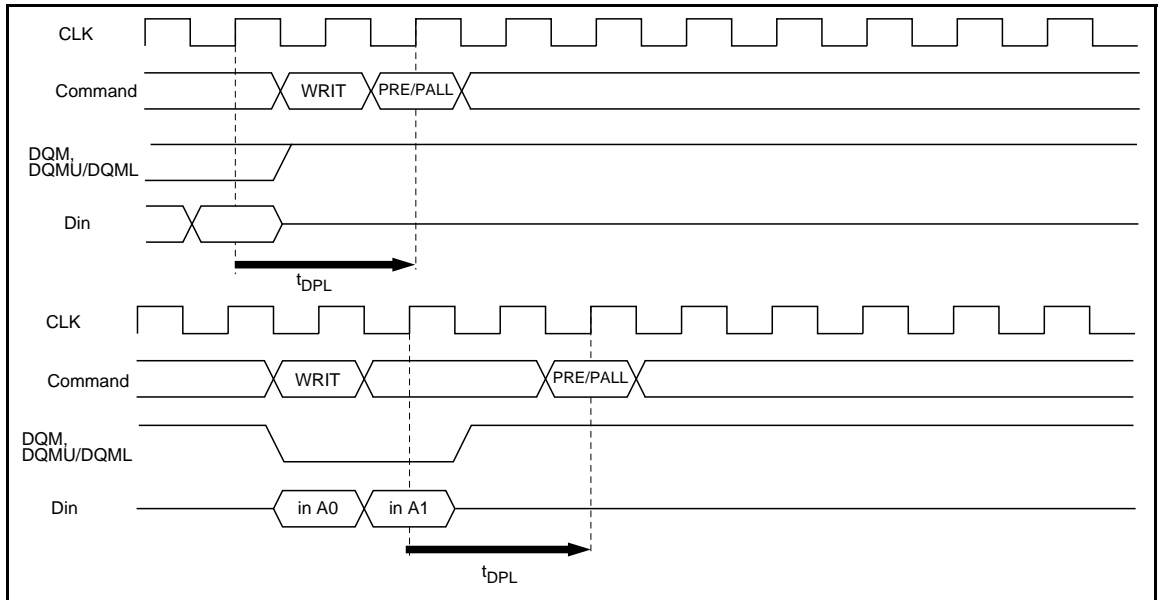

**Burst Length = 4 (To write all data)**

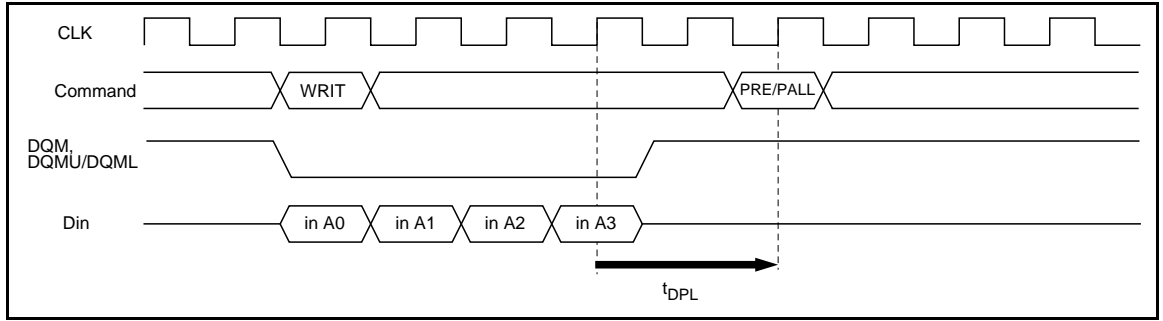

**Bank active command interval:**

- 1. Same bank:** The interval between the two bank-active commands must be no less than  $t_{RC}$ .
- 2. In the case of different bank-active commands:** The interval between the two bank-active commands must be no less than  $t_{RRD}$ .

**Bank active to bank active for same bank**

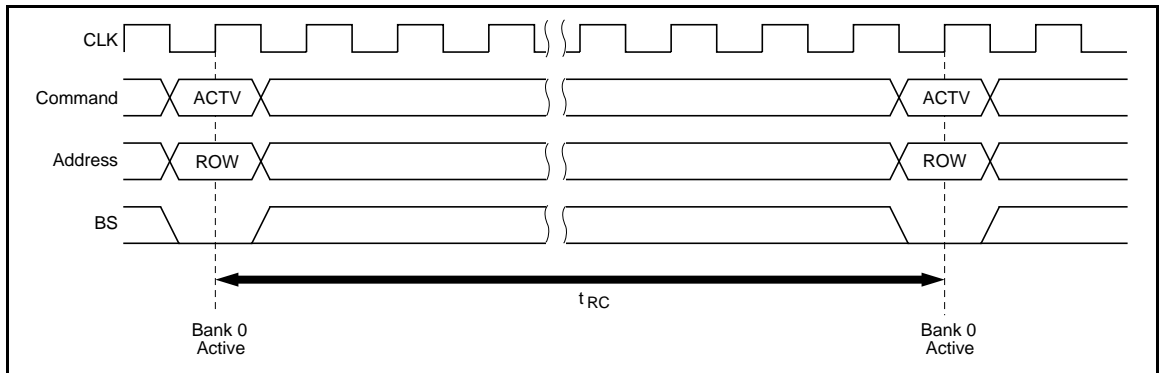



**Bank active to bank active for different bank**

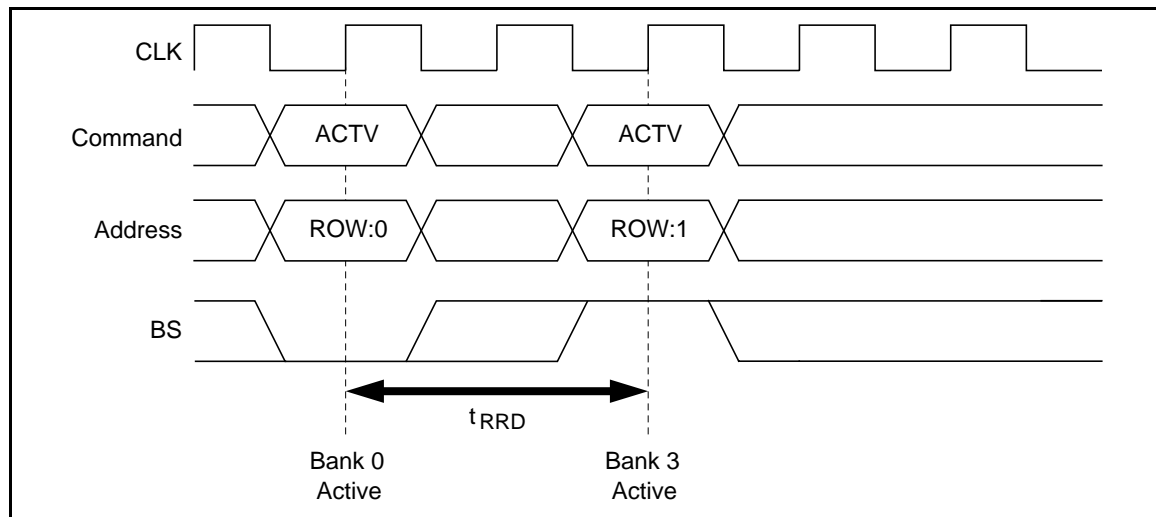

**Mode register set to Bank-active command interval:** The interval between setting the mode register and executing a bank-active command must be no less than  $t_{RSA}$ .

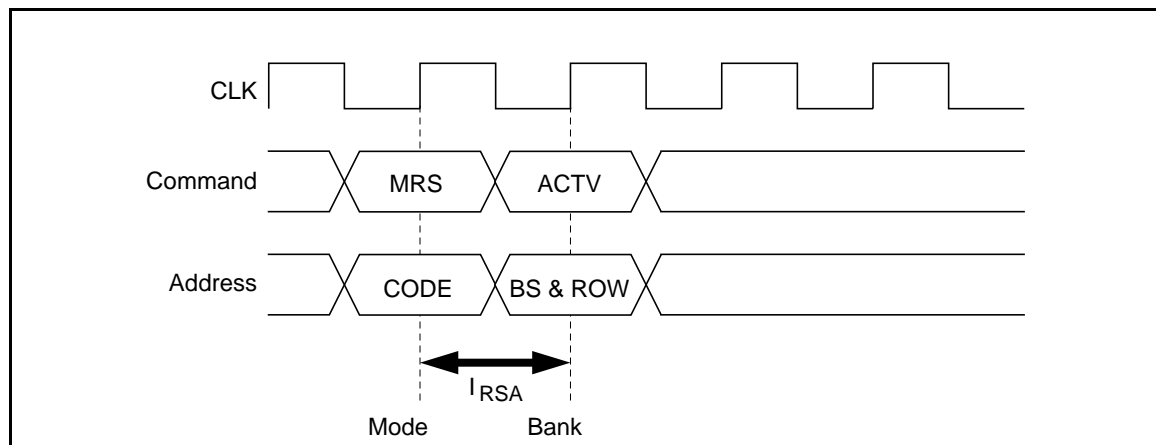

**DQM Control**

The DQMU and DQML mask the upper and lower bytes of the DQ data, respectively. The timing of DQMU/DQML is different during reading and writing.

**Reading:** When data is read, the output buffer can be controlled by DQM, DQMU/DQML. By setting DQM, DQMU/DQML to Low, the output buffer becomes Low-Z, enabling data output. By setting DQM, DQMU/DQML to High, the output buffer becomes High-Z, and the corresponding data is not output. However, internal reading operations continue. The latency of DQM, DQMU/DQML during reading is 2 clocks.

**Writing:** Input data can be masked by DQM, DQMU/DQML. By setting DQM, DQMU/DQML to Low, data can be written. In addition, when DQM, DQMU/DQML is set to High, the corresponding data is not written, and the previous data is held. The latency of DQM, DQMU/DQML during writing is 0 clock.

## Reading

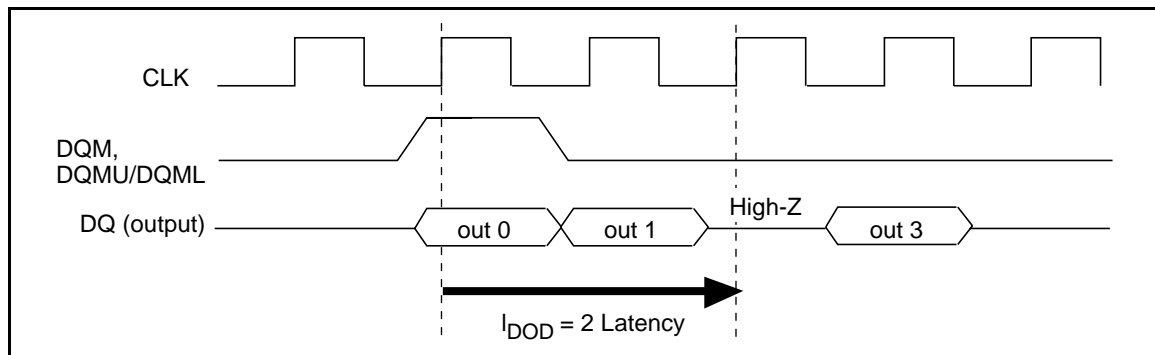

## Writing

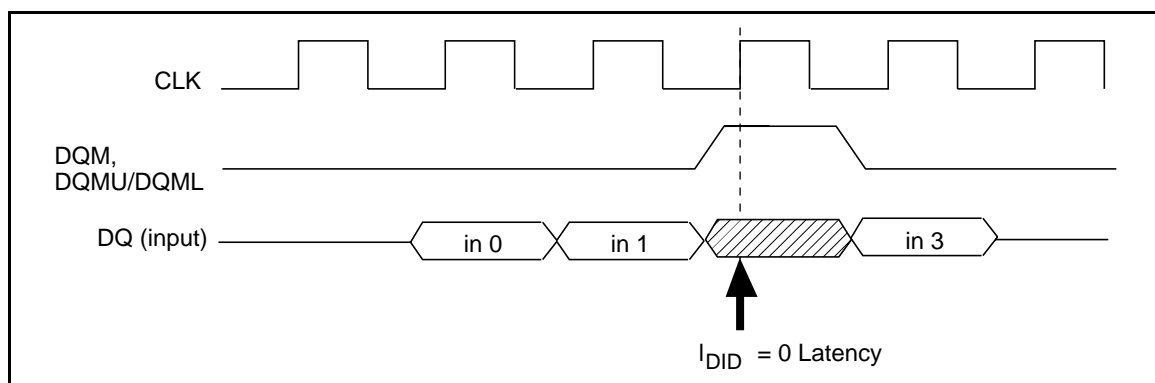

## Refresh

**Auto-refresh:** All the banks must be precharged before executing an auto-refresh command. Since the auto-refresh command updates the internal counter every time it is executed and determines the banks and the ROW addresses to be refreshed, external address specification is not required. The refresh cycle is 4096 cycles/64 ms. (4096 cycles are required to refresh all the ROW addresses.) The output buffer becomes High-Z after auto-refresh start. In addition, since a precharge has been completed by an internal operation after the auto-refresh, an additional precharge operation by the precharge command is not required.

**Self-refresh:** After executing a self-refresh command, the self-refresh operation continues while CKE is held Low. During self-refresh operation, all ROW addresses are refreshed by the internal refresh timer. A self-refresh is terminated by a self-refresh exit command. Before and after self-refresh mode, execute auto-refresh to all refresh addresses in or within 64 ms period on the condition (1) and (2) below.

(1) Enter self-refresh mode within 15.6  $\mu\text{s}$  after either burst refresh or distributed refresh at equal interval to all refresh addresses are completed.

(2) Start burst refresh or distributed refresh at equal interval to all refresh addresses within 15.6  $\mu\text{s}$  after exiting from self-refresh mode.

**Others**

**Power-down mode:** The SDRAM enters power-down mode when CKE goes Low in the IDLE state. In power down mode, power consumption is suppressed by deactivating the input initial circuit. Power down mode continues while CKE is held Low. In addition, by setting CKE to High, the SDRAM exits from the power down mode, and command input is enabled from the next clock. In this mode, internal refresh is not performed.

**Clock suspend mode:** By driving CKE to Low during a bank-active or read/write operation, the SDRAM enters clock suspend mode. During clock suspend mode, external input signals are ignored and the internal state is maintained. When CKE is driven High, the SDRAM terminates clock suspend mode, and command input is enabled from the next clock. For details, refer to the "CKE Truth Table".

**Power-up sequence:** The SDRAM should be gone on the following sequence.

The CLK, CKE,  $\overline{CS}$ , DQM, DQMU/DQML and DQ pins keep low till power stabilizes.

The CLK pin is stabilized within 100  $\mu$ s after power stabilizes before the following initialization sequence.

The CKE and DQM, DQMU/DQML is driven to high between power stabilizes and the initialization sequence.

This SDRAM has  $V_{CC}$  clamp diodes for CLK, CKE,  $\overline{CS}$  DQM, DQMU/DQML and DQ pins. If these pins go high before power up, the large current flows from these pins to  $V_{CC}$  through the diodes.

**Initialization sequence:** When 200  $\mu$ s or more has past after the above power-up sequence, all banks must be precharged using the precharge command (PALL). After  $t_{RP}$  delay, set 8 or more auto refresh commands (REF). Set the mode register set command (MRS) to initialize the mode register. We recommend that by keeping DQM, DQMU/DQML to High, the output buffer becomes High-Z during Initialization sequence, to avoid DQ bus contention on memory system formed with a number of device.

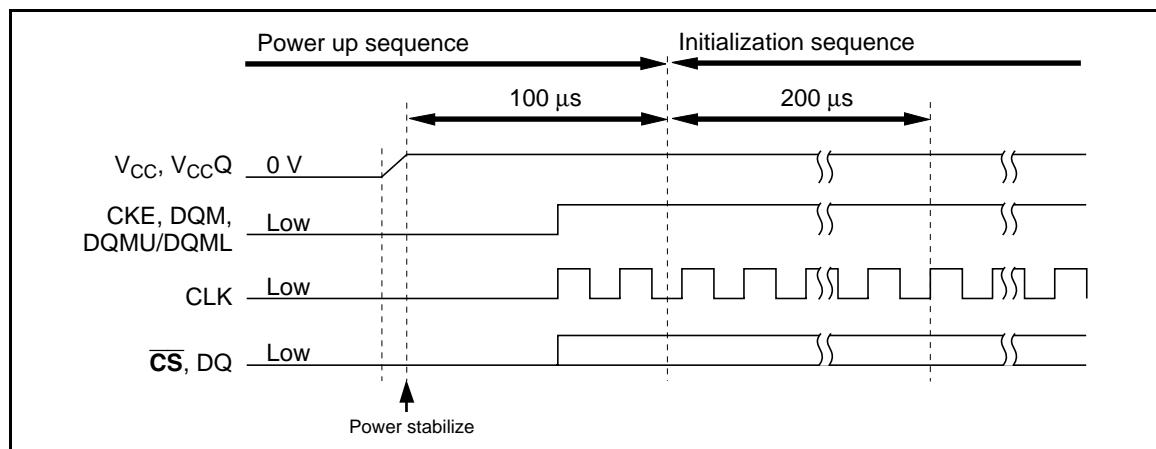

**Absolute Maximum Ratings**

Parameter	Symbol	Value	Unit	Note
Voltage on any pin relative to $V_{SS}$	$V_T$	-0.5 to $V_{CC} + 0.5$ ( $\leq 4.5$ (max))	V	1
Supply voltage relative to $V_{SS}$	$V_{CC}$	-0.5 to +4.5	V	1
Short circuit output current	$I_{out}$	50	mA	

Parameter	Symbol	Value	Unit	Note
Power dissipation	$P_T$	1.0	W	
Operating temperature	$T_{opr}$	0 to +70	°C	
Storage temperature	$T_{stg}$	-55 to +125	°C	

Note: 1. Respect to  $V_{SS}$

## DC Operating Conditions ( $T_a = 0$ to $+70^\circ\text{C}$ )

Parameter	Symbol	Min	Max	Unit	Notes
Supply voltage	$V_{CC}, V_{CCQ}$	2.3	2.7	V	1, 2
	$V_{SS}, V_{SSQ}$	0	0	V	3
Input high voltage	$V_{IH}$	1.7	$V_{CCQ} + 0.5$	V	1, 4
Input low voltage	$V_{IL}$	$V_{SS} - 0.5$	0.7	V	1 5

Notes: 1. All voltage referred to  $V_{SS}$

- The supply voltage with all  $V_{CC}$  and  $V_{CCQ}$  pins must be on the same level.
- The supply voltage with all  $V_{SS}$  and  $V_{SSQ}$  pins must be on the same level.
- $V_{IH}$  (max) =  $V_{CC} + 2.0$  V for pulse width  $\leq 3$  ns at  $V_{CC}$ .
- $V_{IL}$  (min) =  $V_{SS} - 2.0$  V for pulse width  $\leq 3$  ns at  $V_{SS}$ .

## $V_{IL}/V_{IH}$ Clamp

This SDRAM has  $V_{IL}$  and  $V_{IH}$  clamp for CLK, CKE,  $\overline{CS}$ , DQM and I/O pins.

## Minimum $V_{IL}$ Clamp Current

$V_{IL}$ (V)	I (mA)
-2	-32
-1.8	-25
-1.6	-19
-1.4	-13
-1.2	-8
-1	-4
-0.9	-2
-0.8	-0.6
-0.6	0
-0.4	0
-0.2	0
0	0

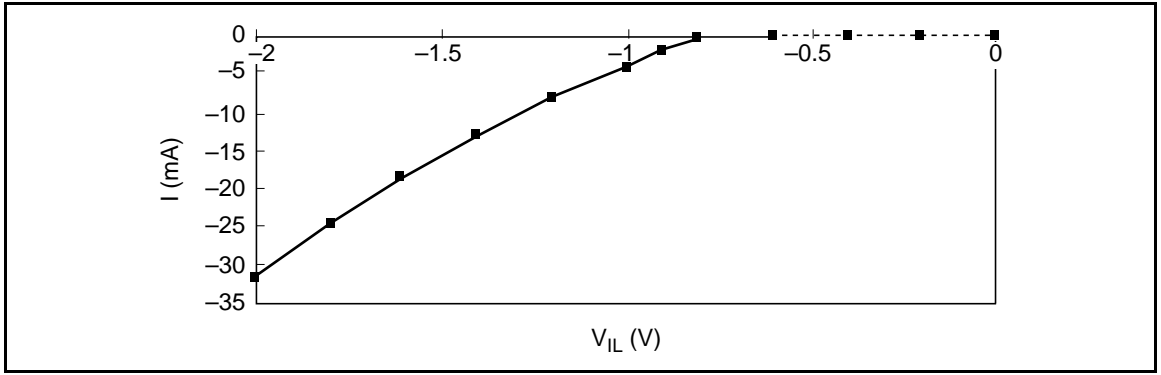

**Minimum  $V_{IH}$  Clamp Current**

$V_{IH}$ (V)	$I$ (mA)
$V_{CC} + 2$	10
$V_{CC} + 1.8$	8
$V_{CC} + 1.6$	5.5
$V_{CC} + 1.4$	3.5
$V_{CC} + 1.2$	1.5
$V_{CC} + 1$	0.3
$V_{CC} + 0.8$	0
$V_{CC} + 0.6$	0
$V_{CC} + 0.4$	0
$V_{CC} + 0.2$	0
$V_{CC} + 0$	0

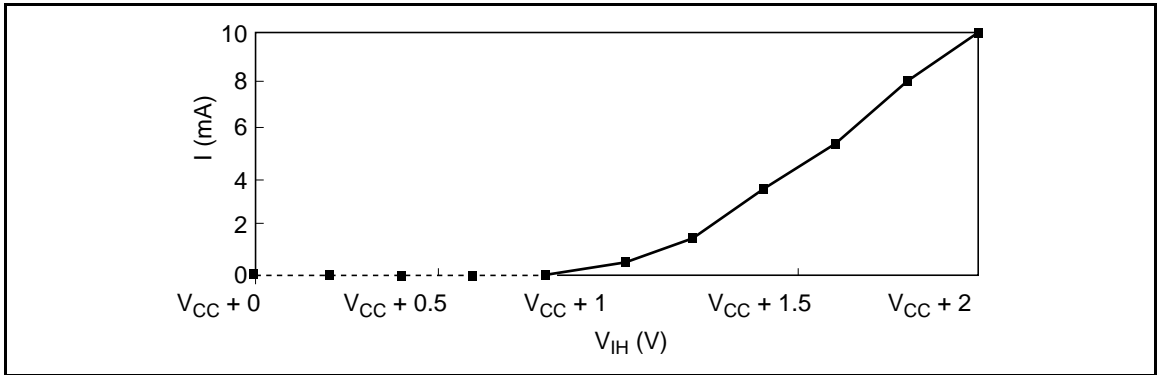

$I_{OL}/I_{OH}$  Characteristics

Output Low Current ( $I_{OL}$ )

Vout (V)	$I_{OL}$	
	Min (mA)	Max (mA)
0	0	0
0.4	17	58
0.65	25	84
0.85	30	101
1	32	110
1.4	35	124
1.5	35	124
1.65	35	124
1.8	35	124
1.95	35	124
2.3	35	124
2.5	35	124
2.7	35	124

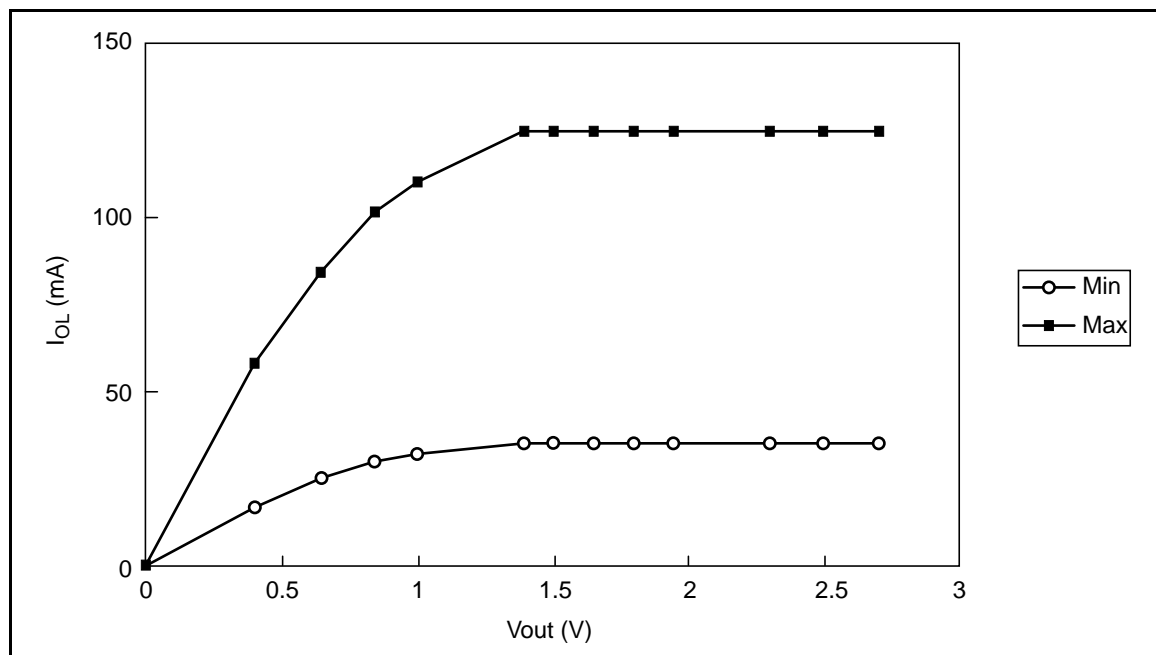

Output High Current ( $I_{OH}$ ) ( $T_a = 0$  to  $70^\circ\text{C}$ ,  $V_{CC}$ ,  $V_{CCQ} = 2.3\text{V}$  to  $2.7$ ,  $V_{SS}$ ,  $V_{SSQ} = 0$  V)

Vout (V)	$I_{OH}$	
	Min (mA)	Max (mA)
3.45	—	0
3.3	—	0
2.7	—	0
2.5	—	-30
2.3	0	-57
2	-14	-92
1.8	-23	-112
1.65	-28	-124
1.5	-33	-135
1.4	-36	-142
1	-45	-160
0	-51	-166

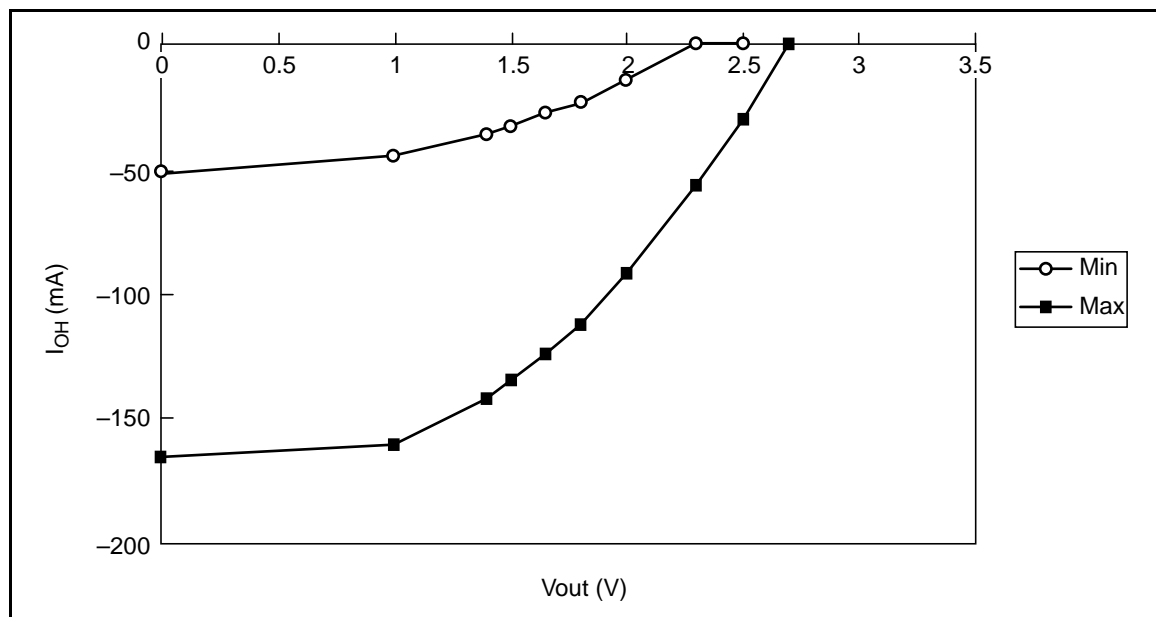

**DC Characteristics (Ta = 0 to 70°C, V<sub>CC</sub>, V<sub>CCQ</sub> = 2.5 V ± 0.2 V, V<sub>SS</sub>, V<sub>SSQ</sub> = 0 V) (HM52Y64165F)**

Parameter	Symbol	HM52Y64165F		Unit	Test conditions	Notes
		Min	Max			
Operating current ( $\overline{\text{CAS}}$ latency = 2)	I <sub>CC1</sub>	—	TBD	mA	Burst length = 1 t <sub>RC</sub> = min	1, 2, 3
	I <sub>CC1</sub>	—	TBD	mA		
Standby current in power down	I <sub>CC2P</sub>	—	3	mA	CKE = V <sub>IL</sub> , t <sub>CK</sub> = 12 ns	6
Standby current in power down (input signal stable)	I <sub>CC2PS</sub>	—	2	mA	CKE = V <sub>IL</sub> , t <sub>CK</sub> = ∞	7
Standby current in non power down	I <sub>CC2N</sub>	—	15	mA	CKE, $\overline{\text{CS}}$ = V <sub>IH</sub> , t <sub>CK</sub> = 12 ns	4
Standby current in non power down (input signal stable)	I <sub>CC2NS</sub>	—	9	mA	CKE = V <sub>IH</sub> , t <sub>CK</sub> = ∞	9
Active standby current in power down	I <sub>CC3P</sub>	—	6	mA	CKE = V <sub>IL</sub> , t <sub>CK</sub> = 12 ns	1, 2, 6
Active standby current in power down (input signal stable)	I <sub>CC3PS</sub>	—	5	mA	CKE = V <sub>IL</sub> , t <sub>CK</sub> = ∞	2, 7
Active standby current in non power down	I <sub>CC3N</sub>	—	25	mA	CKE, $\overline{\text{CS}}$ = V <sub>IH</sub> , t <sub>CK</sub> = 12 ns	1, 2, 4
Active standby current in non power down (input signal stable)	I <sub>CC3NS</sub>	—	15	mA	CKE = V <sub>IH</sub> , t <sub>CK</sub> = ∞	2, 9
Burst operating current ( $\overline{\text{CAS}}$ latency = 2)	I <sub>CC4</sub>	—	TBD	mA	t <sub>CK</sub> = min, BL = 4	1, 2, 5
	I <sub>CC4</sub>	—	TBD	mA		
Refresh current	I <sub>CC5</sub>	—	TBD	mA	t <sub>RC</sub> = min	3
Self refresh current	I <sub>CC6</sub>	—	1	mA	V <sub>IH</sub> ≥ V <sub>CC</sub> - 0.2 V V <sub>IL</sub> ≤ 0.2 V	8
Input leakage current	I <sub>LI</sub>	-10	10	μA	0 ≤ Vin ≤ V <sub>CC</sub>	
Output leakage current	I <sub>LO</sub>	-10	10	μA	0 ≤ Vout ≤ V <sub>CC</sub> DQ = disable	
Output high voltage	V <sub>OH</sub>	2.0	—	V	I <sub>OH</sub> = -1 mA	
Output low voltage	V <sub>OL</sub>	—	0.4	V	I <sub>OL</sub> = 1 mA	



DC Characteristics (Ta = 0 to 70°C, V<sub>CC</sub>, V<sub>CCQ</sub> = 2.5 V ± 0.2 V, V<sub>SS</sub>, V<sub>SSQ</sub> = 0 V) (HM52Y64805F)

Parameter	Symbol	HM52Y64805F		Unit	Test conditions	Notes
		Min	Max			
Operating current ( $\overline{\text{CAS}}$ latency = 2)	I <sub>CC1</sub>	—	TBD	mA	Burst length = 1 t <sub>RC</sub> = min	1, 2, 3
( $\overline{\text{CAS}}$ latency = 3)	I <sub>CC1</sub>	—	TBD	mA		
Standby current in power down	I <sub>CC2P</sub>	—	3	mA	CKE = V <sub>IL</sub> , t <sub>CK</sub> = 12 ns	6
Standby current in power down (input signal stable)	I <sub>CC2PS</sub>	—	2	mA	CKE = V <sub>IL</sub> , t <sub>CK</sub> = ∞	7
Standby current in non power down	I <sub>CC2N</sub>	—	15	mA	CKE, $\overline{\text{CS}}$ = V <sub>IH</sub> , t <sub>CK</sub> = 12 ns	4
Standby current in non power down (input signal stable)	I <sub>CC2NS</sub>	—	9	mA	CKE = V <sub>IH</sub> , t <sub>CK</sub> = ∞	9
Active standby current in power down	I <sub>CC3P</sub>	—	6	mA	CKE = V <sub>IL</sub> , t <sub>CK</sub> = 12 ns	1, 2, 6
Active standby current in power down (input signal stable)	I <sub>CC3PS</sub>	—	5	mA	CKE = V <sub>IL</sub> , t <sub>CK</sub> = ∞	2, 7
Active standby current in non power down	I <sub>CC3N</sub>	—	25	mA	CKE, $\overline{\text{CS}}$ = V <sub>IH</sub> , t <sub>CK</sub> = 12 ns	1, 2, 4
Active standby current in non power down (input signal stable)	I <sub>CC3NS</sub>	—	15	mA	CKE = V <sub>IH</sub> , t <sub>CK</sub> = ∞	2, 9
Burst operating current ( $\overline{\text{CAS}}$ latency = 2)	I <sub>CC4</sub>	—	TBD	mA	t <sub>CK</sub> = min, BL = 4	1, 2, 5
( $\overline{\text{CAS}}$ latency = 3)	I <sub>CC4</sub>	—	TBD	mA		
Refresh current	I <sub>CC5</sub>	—	TBD	mA	t <sub>RC</sub> = min	3
Self refresh current	I <sub>CC6</sub>	—	1	mA	V <sub>IH</sub> ≥ V <sub>CC</sub> - 0.2 V V <sub>IL</sub> ≤ 0.2 V	8
Input leakage current	I <sub>LI</sub>	-10	10	μA	0 ≤ Vin ≤ V <sub>CC</sub>	
Output leakage current	I <sub>LO</sub>	-10	10	μA	0 ≤ Vout ≤ V <sub>CC</sub> DQ = disable	
Output high voltage	V <sub>OH</sub>	2.0	—	V	I <sub>OH</sub> = -1 mA	
Output low voltage	V <sub>OL</sub>	—	0.4	V	I <sub>OL</sub> = 1 mA	

**DC Characteristics (Ta = 0 to 70°C, V<sub>CC</sub>, V<sub>CCQ</sub> = 2.5 V ± 0.125 V, V<sub>SS</sub>, V<sub>SSQ</sub> = 0 V) (HM52Y64405F)**

Parameter	Symbol	HM52Y64405F		Unit	Test conditions	Notes
		Min	Max			
Operating current ( $\overline{\text{CAS}}$ latency = 2)	I <sub>CC1</sub>	—	TBD	mA	Burst length = 1 t <sub>RC</sub> = min	1, 2, 3
	I <sub>CC1</sub>	—	TBD			
Standby current in power down	I <sub>CC2P</sub>	—	3	mA	CKE = V <sub>IL</sub> , t <sub>CK</sub> = 12 ns	6
Standby current in power down (input signal stable)	I <sub>CC2PS</sub>	—	2			
Standby current in non power down	I <sub>CC2N</sub>	—	15	mA	CKE, $\overline{\text{CS}}$ = V <sub>IH</sub> , t <sub>CK</sub> = 12 ns	4
Standby current in non power down (input signal stable)	I <sub>CC2NS</sub>	—	9			
Active standby current in power down	I <sub>CC3P</sub>	—	6	mA	CKE = V <sub>IL</sub> , t <sub>CK</sub> = 12 ns	1, 2, 6
Active standby current in power down (input signal stable)	I <sub>CC3PS</sub>	—	5			
Active standby current in non power down	I <sub>CC3N</sub>	—	25	mA	CKE, $\overline{\text{CS}}$ = V <sub>IH</sub> , t <sub>CK</sub> = 12 ns	1, 2, 4
Active standby current in non power down (input signal stable)	I <sub>CC3NS</sub>	—	15			
Burst operating current ( $\overline{\text{CAS}}$ latency = 2)	I <sub>CC4</sub>	—	TBD	mA	t <sub>CK</sub> = min, BL = 4	1, 2, 5
( $\overline{\text{CAS}}$ latency = 3)	I <sub>CC4</sub>	—	TBD			
Refresh current	I <sub>CC5</sub>	—	TBD	mA	t <sub>RC</sub> = min	3
Self refresh current	I <sub>CC6</sub>	—	1			
Input leakage current	I <sub>LI</sub>	-10	10	μA	0 ≤ Vin ≤ V <sub>CC</sub>	
Output leakage current	I <sub>LO</sub>	-10	10			
Output high voltage	V <sub>OH</sub>	2.0	—	V	I <sub>OH</sub> = -1 mA	
Output low voltage	V <sub>OL</sub>	—	0.4			

Notes: 1. I<sub>CC</sub> depends on output load condition when the device is selected. I<sub>CC</sub> (max) is specified at the output open condition.

2. One bank operation.
3. Input signals are changed once per one clock.
4. Input signals are changed once per two clocks.
5. Input signals are changed once per four clocks.
6. After power down mode, CLK operating current.
7. After power down mode, no CLK operating current.
8. After self refresh mode set, self refresh current.
9. Input signals are V<sub>IH</sub> or V<sub>IL</sub> fixed.

**Capacitance (Ta = 25°C, V<sub>CC</sub>, V<sub>CCQ</sub> = 2.5 V ± 0.2 V)**

Parameter	Symbol	Min	Max	Unit	Notes
Input capacitance (CLK)	C <sub>I1</sub>	2.5	4.0	pF	1, 2, 4
Input capacitance (Input)	C <sub>I2</sub>	2.5	5.0	pF	1, 2, 4
Output capacitance (DQ)	C <sub>O</sub>	4	6.5	pF	1, 2, 3, 4

- Notes: 1. Capacitance measured with Boonton Meter or effective capacitance measuring method.  
 2. Measurement condition: f = 1 MHz, 1.4 V bias, 200 mV swing.  
 3. DQM, DQMU/DQML = V<sub>IH</sub> to disable Dout.  
 4. This parameter is sampled and not 100% tested.

**AC Characteristics (Ta = 0 to 70°C, V<sub>CC</sub>, V<sub>CCQ</sub> = 2.5 V ± 0.2 V, V<sub>SS</sub>, V<sub>SSQ</sub> = 0 V)**

Parameter	HITACHI Symbol	PC/100 Symbol	HM52Y64165F/ HM52Y64805F/ HM52Y64405F				Unit	Notes
			-75		-80			
			Min	Max	Min	Max		
System clock cycle time (CAS latency = 2)	t <sub>CK</sub>	Tclk	10	—	10	—	ns	1
(CAS latency = 3)	t <sub>CK</sub>	Tclk	7.5	—	8	—	ns	
CLK high pulse width	t <sub>CKH</sub>	Tch	2.5	—	2.5	—	ns	1
CLK low pulse width	t <sub>CKL</sub>	Tcl	2.5	—	2.5	—	ns	1
Access time from CLK (CAS latency = 2)	t <sub>AC</sub>	Tac	—	6	—	6	ns	1, 2
(CAS latency = 3)	t <sub>AC</sub>	Tac	—	5.5	—	6	ns	
Data-out hold time	t <sub>OH</sub>	Toh	2.5	—	3	—	ns	1, 2
CLK to Data-out low impedance	t <sub>LZ</sub>		2	—	2	—	ns	1, 2, 3
CLK to Data-out high impedance (CAS latency = 2, 3)	t <sub>HZ</sub>		—	6	—	6	ns	1, 4
Input setup time	t <sub>AS</sub> , t <sub>CS</sub> , t <sub>DS</sub> , t <sub>CES</sub>	Tsi	1.8	—	2	—	ns	1, 5, 6
CKE setup time for power down exit	t <sub>CESP</sub>	Tpde	1.8	—	2	—	ns	1
Input hold time	t <sub>AH</sub> , t <sub>CH</sub> , t <sub>DH</sub> , t <sub>CEH</sub>	Thi	0.8	—	1	—	ns	1, 6
Ref/Active to Ref/Active command period	t <sub>RC</sub>	Trc	67.5	—	70	—	ns	1
Active to Precharge command period	t <sub>RAS</sub>	Tras	45	120000	48	120000	ns	1
Active command to column command (same bank)	t <sub>RCD</sub>	Trcd	20	—	20	—	ns	1
Precharge to active command period	t <sub>RP</sub>	Trp	20	—	20	—	ns	1
Write recovery or data-in to precharge lead time	t <sub>DPL</sub>	Tdpl	10	—	10	—	ns	1

Parameter	HITACHI Symbol	PC/100 Symbol	HM52Y64165F/ HM52Y64805F/ HM52Y64405F				Unit	Notes
			-75		-80			
			Min	Max	Min	Max		
Active (a) to Active (b) command period	$t_{RRD}$	$Trrd$	15	—	15	—	ns	1
Transition time (rise to fall)	$t_T$		1	5	1	5	ns	
Refresh period	$t_{REF}$		—	64	—	64	ms	

- Notes: 1. AC measurement assumes  $t_T = 1$  ns. Reference level for timing of input signals is 1.2 V.  
 2. Access time is measured at 1.2 V. Load condition is  $CL = 50$  pF.  
 3.  $t_{LZ}$  (max) defines the time at which the outputs achieves the low impedance state.  
 4.  $t_{HZ}$  (max) defines the time at which the outputs achieves the high impedance state.  
 5.  $t_{CES}$  define CKE setup time to CLK rising edge except power down exit command.  
 6.  $t_{AS}/t_{AH}$ : Address,  $t_{CS}/t_{CH}$ :  $\overline{CS}$ ,  $\overline{RAS}$ ,  $\overline{CAS}$ ,  $\overline{WE}$ , DQM, DQMU/DQML  
 $t_{DS}/t_{DH}$ : Data-in,  $t_{CES}/t_{CEH}$ : CKE

### Test Conditions

- Input and output timing reference levels: 1.2 V
- Input waveform and output load: See following figures

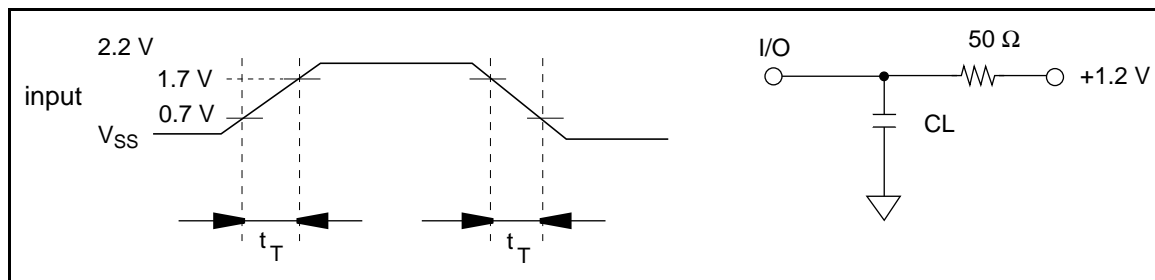

### Relationship Between Frequency and Minimum Latency

Parameter	HITACHI Symbol	PC/100 Symbol	HM52Y64165F/ HM52Y64805F/ HM52Y64405F		Notes
			-75	-80	
			133	125	
Frequency (MHz)					
$t_{CK}$ (ns)					
Active command to column command (same bank)	$t_{RCD}$		3	3	1
Active command to active command (same bank)	$t_{RC}$		9	9	= [ $t_{RAS} + t_{RP}$ ] 1
Active command to precharge command (same bank)	$t_{RAS}$		6	6	1
Precharge command to active command (same bank)	$t_{RP}$		3	3	1

Parameter			HM52Y64165F/ HM52Y64805F/ HM52Y64405F		Notes
			-75	-80	
	Frequency (MHz)	HITACHI Symbol	PC/100 Symbol	133	
t <sub>CK</sub> (ns)					
Write recovery or data-in to precharge command (same bank)	I <sub>DPL</sub>	T <sub>dpl</sub>	2	2	1
Active command to active command (different bank)	I <sub>RRD</sub>		2	2	1
Self refresh exit time	I <sub>SREX</sub>	T <sub>srx</sub>	1	1	2
Last data in to active command (Auto precharge, same bank)	I <sub>APW</sub>	T <sub>dal</sub>	5	5	= [I <sub>DPL</sub> + I <sub>RP</sub> ]
Self refresh exit to command input	I <sub>SEC</sub>		9	9	= [I <sub>RC</sub> ] 3
Precharge command to high impedance (CAS latency = 2)	I <sub>HZP</sub>	T <sub>roh</sub>	2	2	
(CAS latency = 3)	I <sub>HZP</sub>	T <sub>roh</sub>	3	3	
Last data out to active command (auto precharge) (same bank)	I <sub>APR</sub>		1	1	
Last data out to precharge (early precharge) (CAS latency = 2)	I <sub>EP</sub>		-1	-1	
(CAS latency = 3)	I <sub>EP</sub>		-2	-2	
Column command to column command	I <sub>CCD</sub>	T <sub>ccd</sub>	1	1	
Write command to data in latency	I <sub>WCD</sub>	T <sub>dwd</sub>	0	0	
DQM to data in	I <sub>DID</sub>	T <sub>dqm</sub>	0	0	
DQM to data out	I <sub>DOD</sub>	T <sub>dqz</sub>	2	2	
CKE to CLK disable	I <sub>CLE</sub>	T <sub>cke</sub>	1	1	
Register set to active command	I <sub>RSA</sub>	T <sub>mrd</sub>	1	1	
CS to command disable	I <sub>CDD</sub>		0	0	
Power down exit to command input	I <sub>PEC</sub>		1	1	
Burst stop to output valid data hold (CAS latency = 2)	I <sub>BSR</sub>		1	1	
(CAS latency = 3)	I <sub>BSR</sub>		2	2	
Burst stop to output high impedance (CAS latency = 2)	I <sub>BSH</sub>		2	2	
(CAS latency = 3)	I <sub>BSH</sub>		3	3	
Burst stop to write data ignore	I <sub>BSW</sub>		0	0	

Notes: 1. I<sub>RCD</sub> to I<sub>RRD</sub> are recommended value.

2. Be valid [DSEL] or [NOP] at next command of self refresh exit.

3. Except [DSEL] and [NOP].

## Timing Waveforms

### Read Cycle

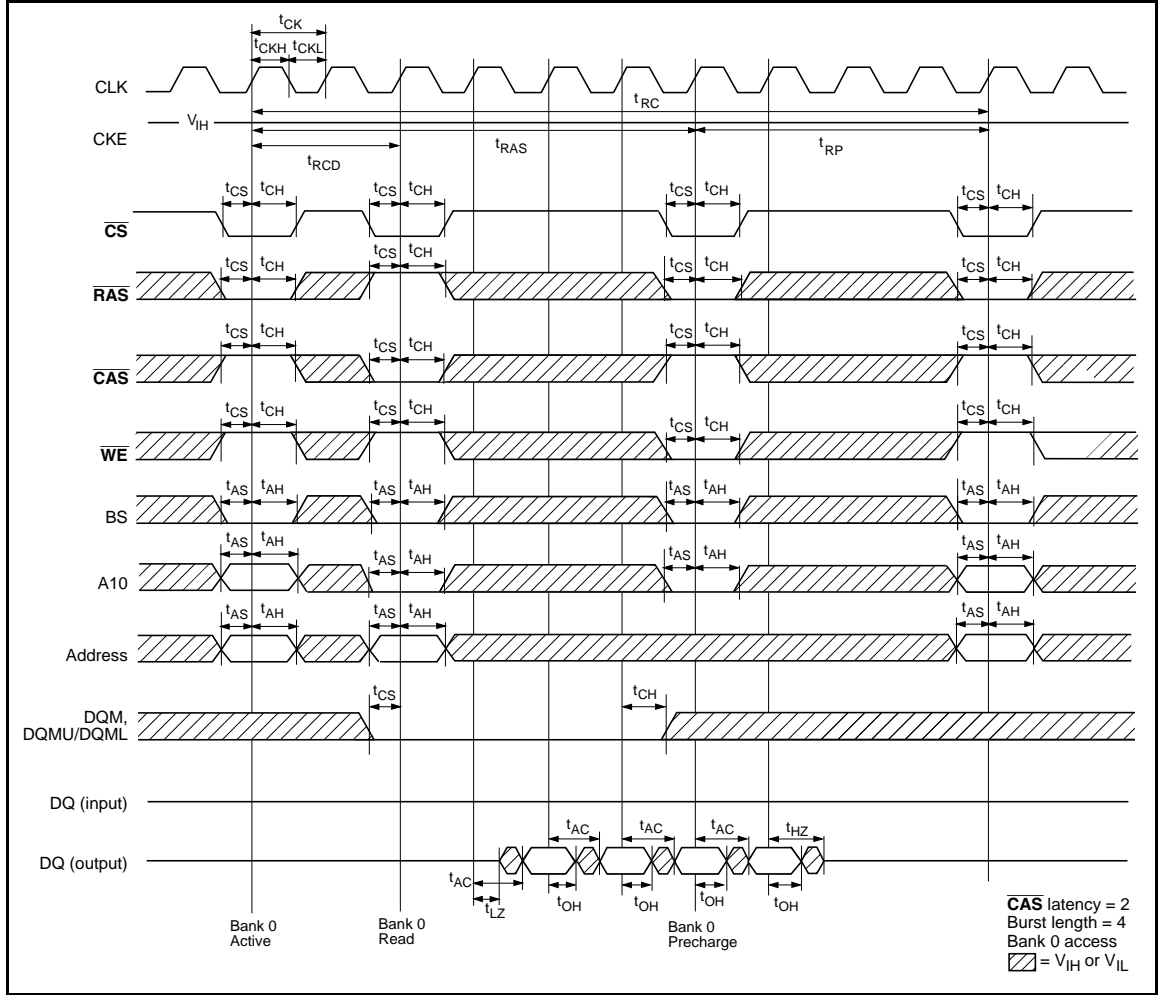

Write Cycle

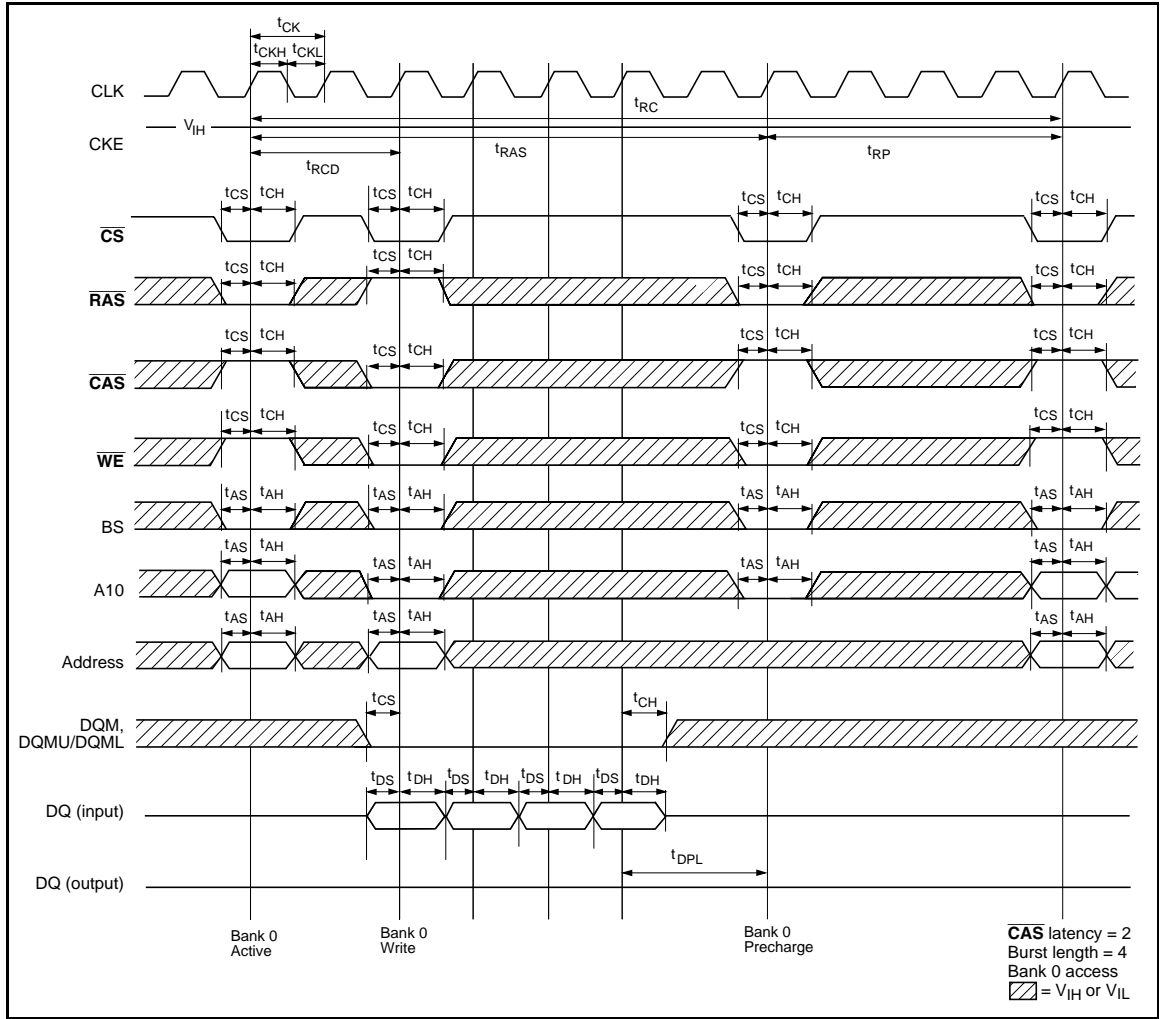

Mode Register Set Cycle

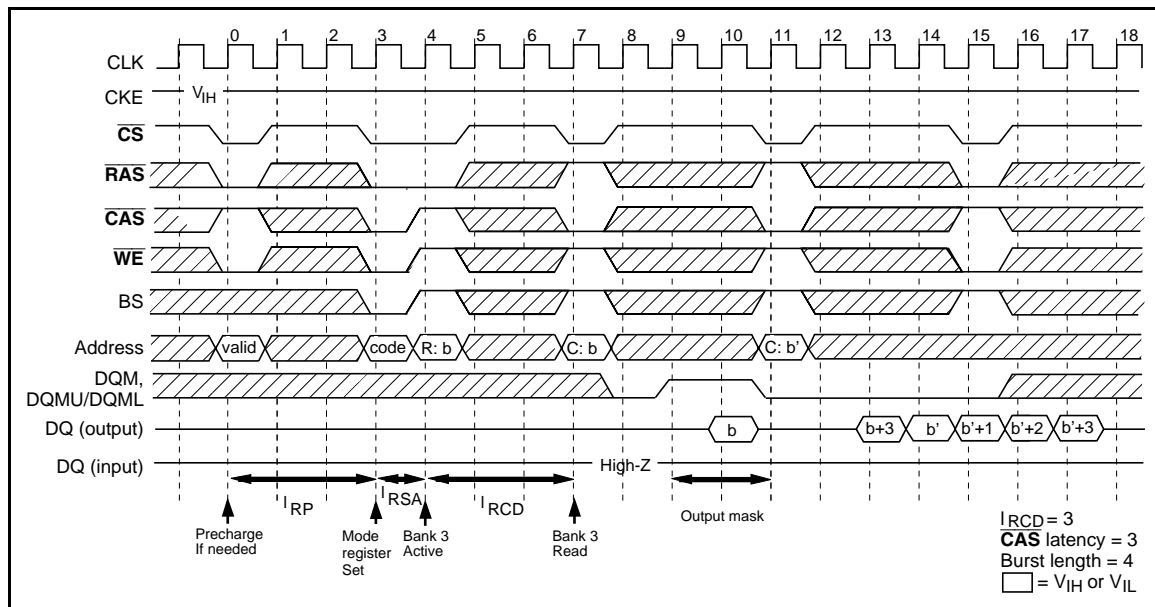

Read Cycle/Write Cycle

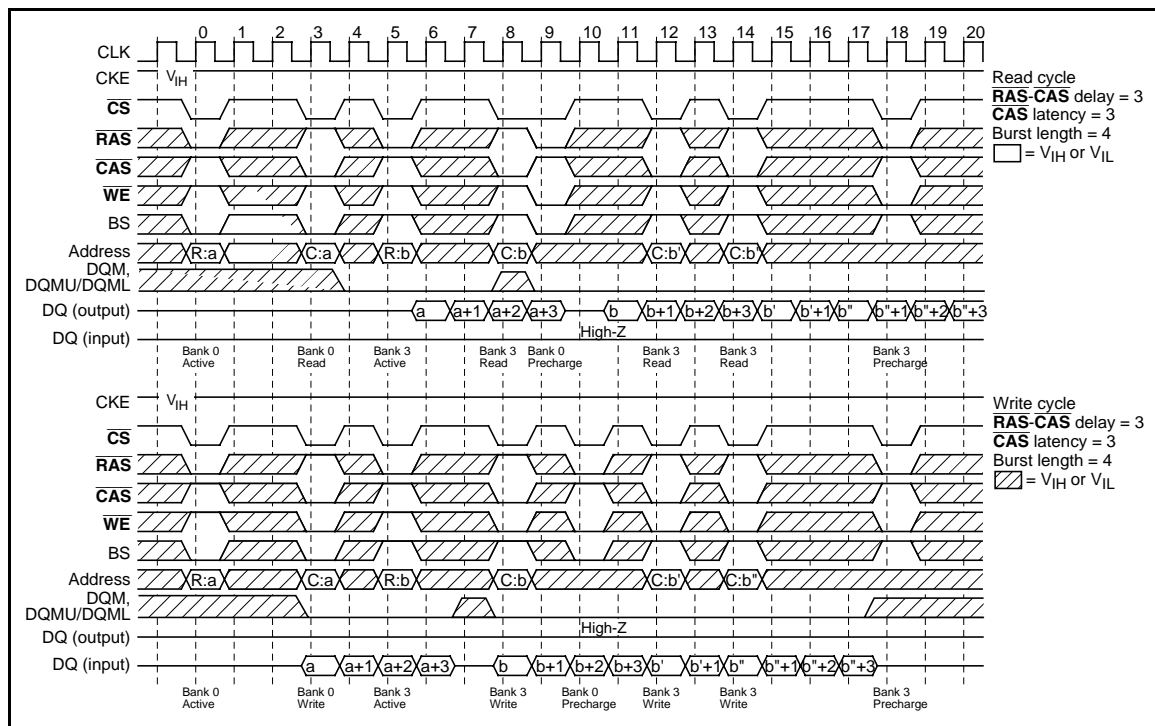



Read/Single Write Cycle

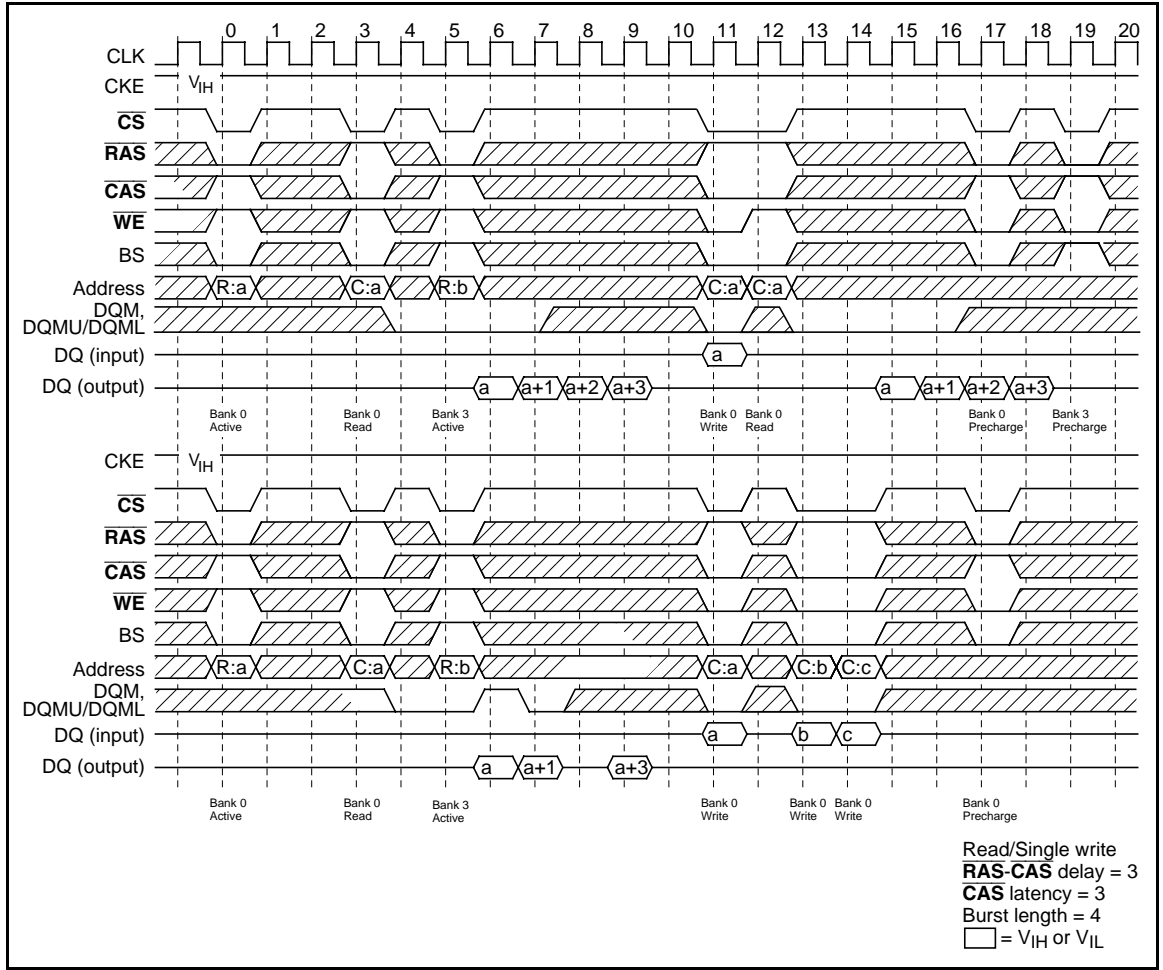

Read/Burst Write Cycle

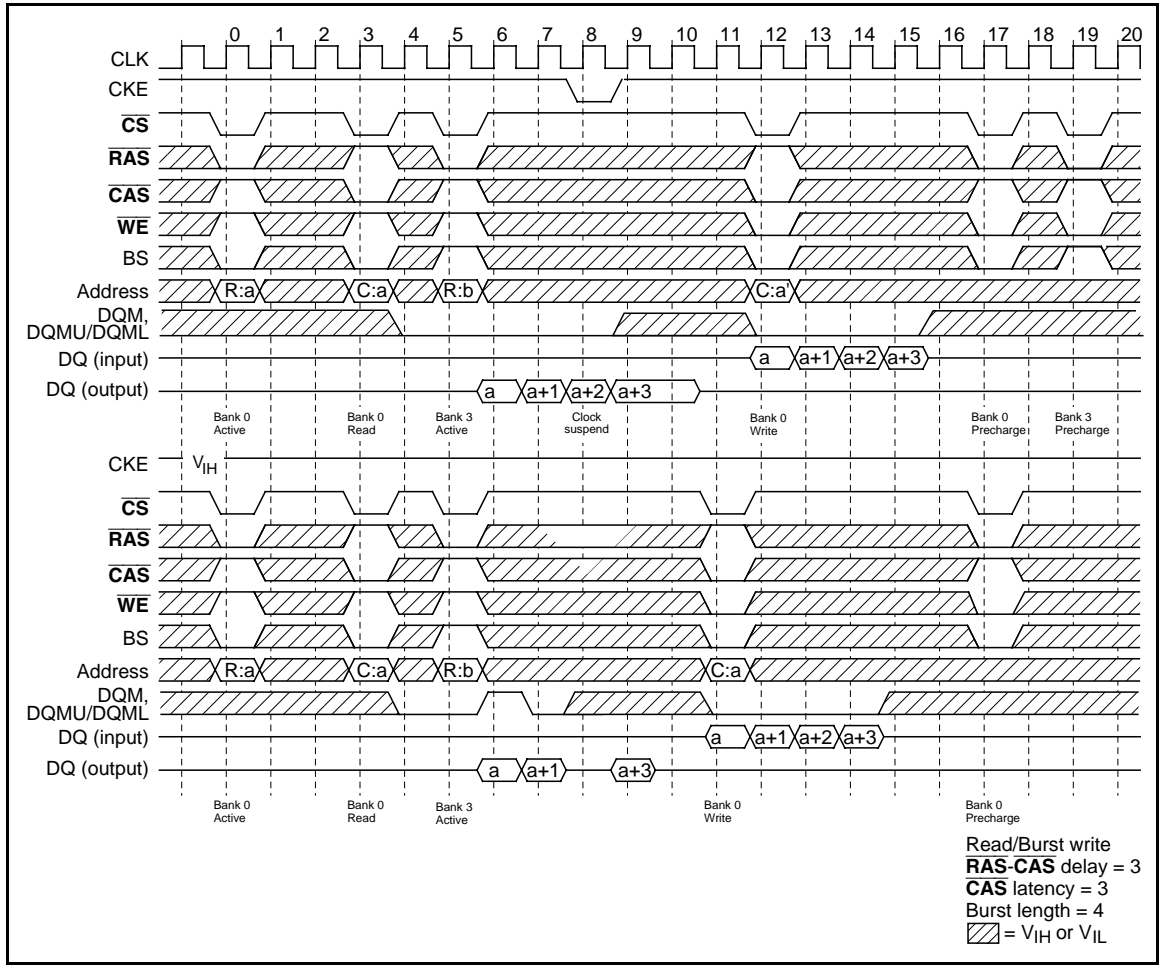

Full Page Read/Write Cycle

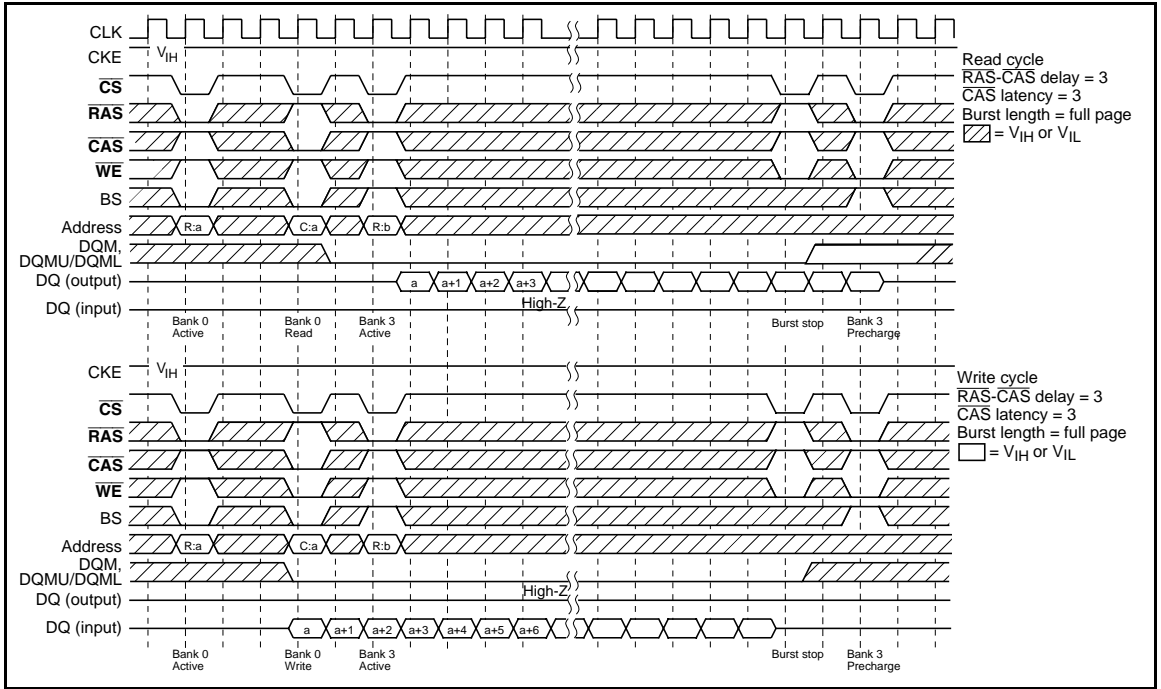

Auto Refresh Cycle

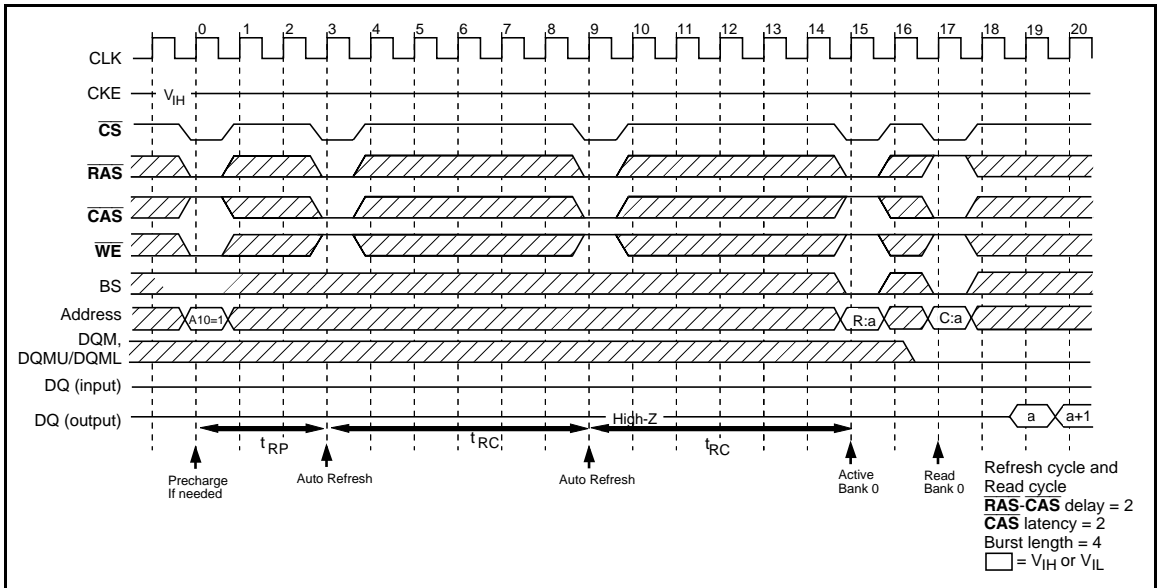

### Self Refresh Cycle

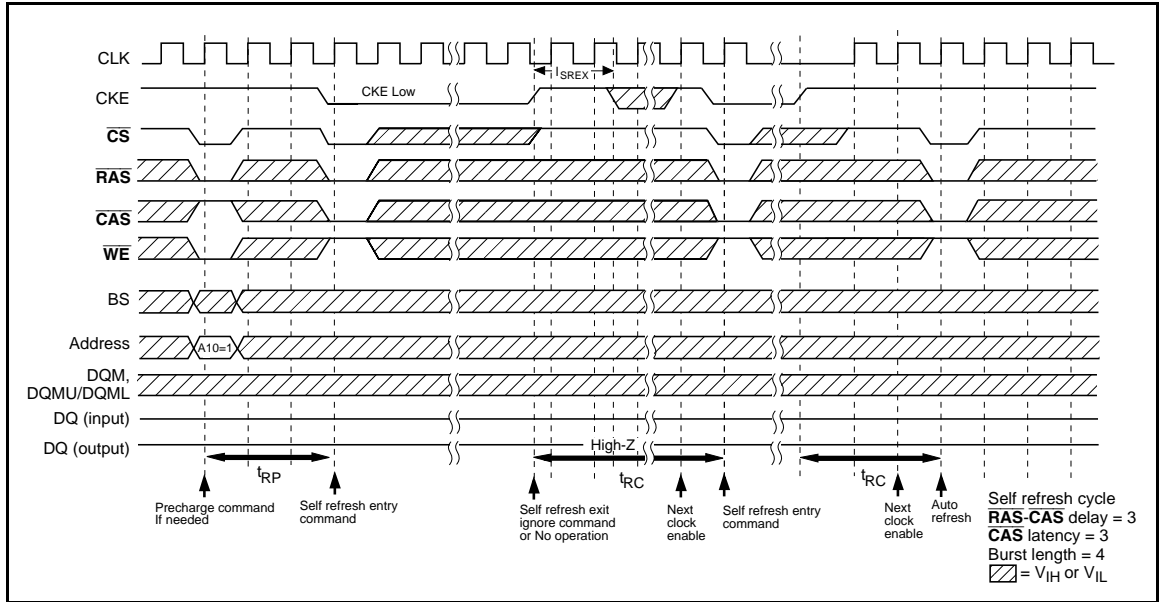

### Clock Suspend Mode

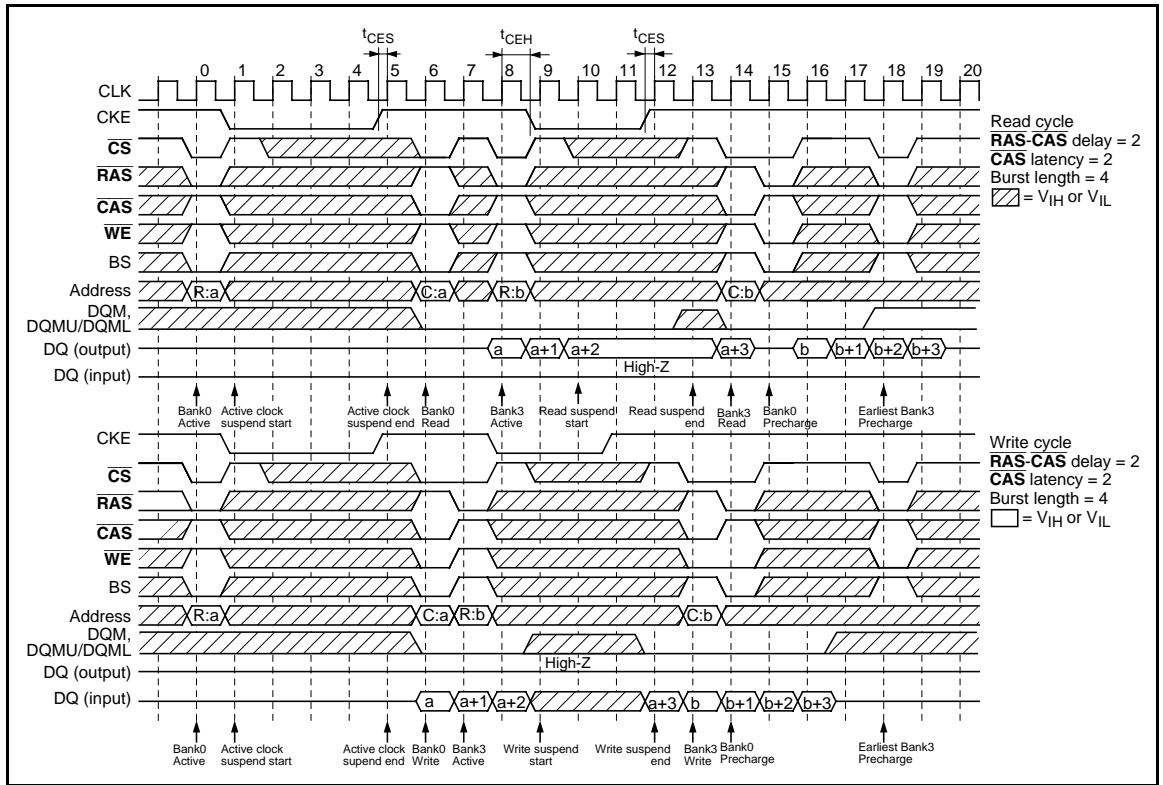

Power Down Mode

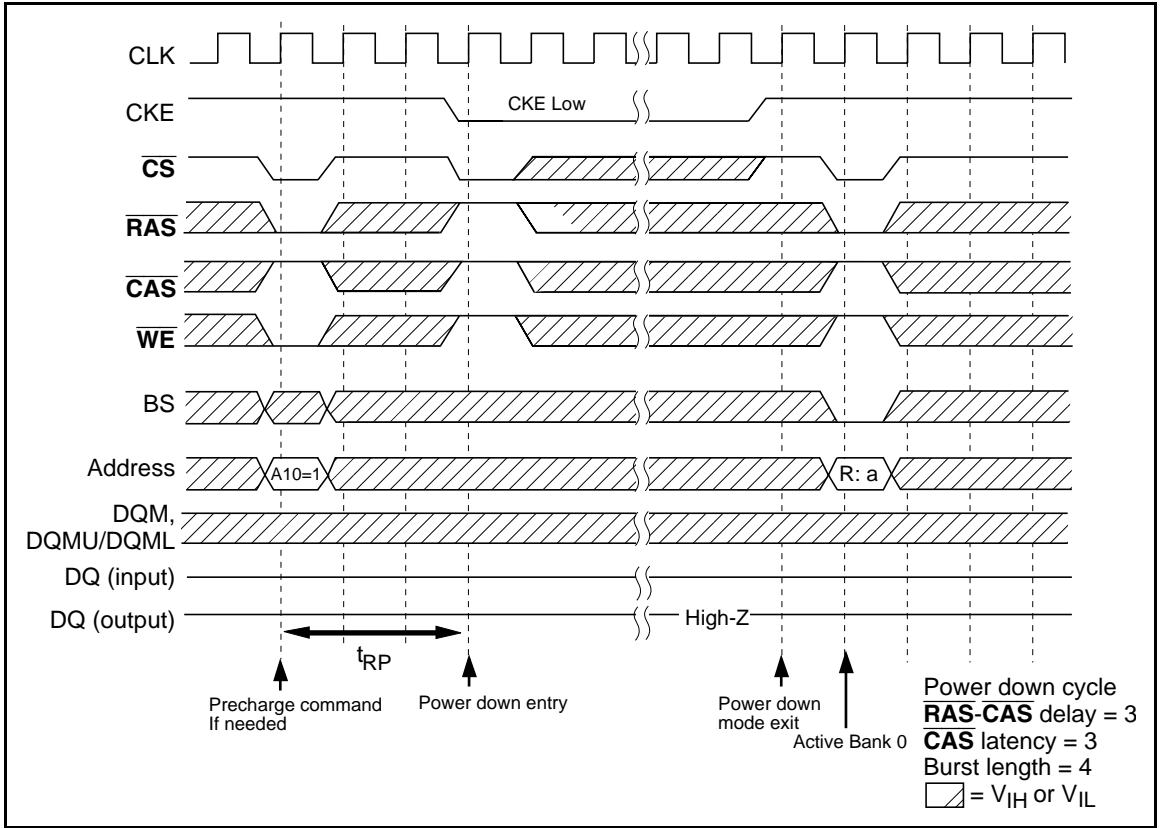

Initialization Sequence

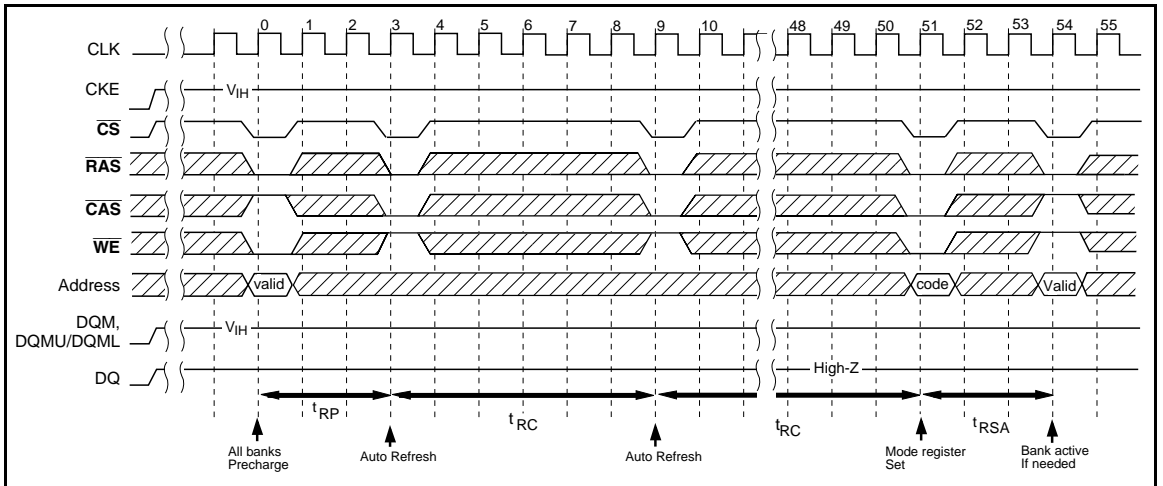

## Package Dimensions

### HM52Y64165FTT/HM52Y64805FTT/HM52Y64405FTT Series (TTP-54D)

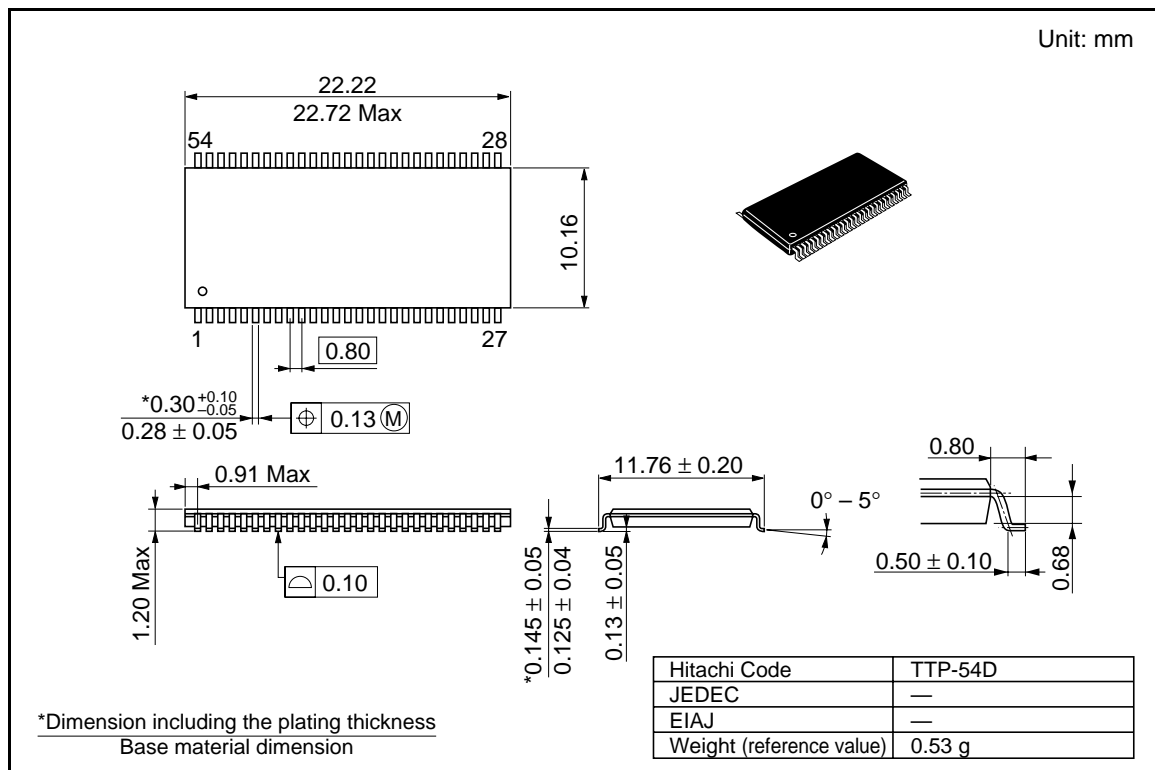

## Cautions

1. Hitachi neither warrants nor grants licenses of any rights of Hitachi's or any third party's patent, copyright, trademark, or other intellectual property rights for information contained in this document. Hitachi bears no responsibility for problems that may arise with third party's rights, including intellectual property rights, in connection with use of the information contained in this document.
2. Products and product specifications may be subject to change without notice. Confirm that you have received the latest product standards or specifications before final design, purchase or use.
3. Hitachi makes every attempt to ensure that its products are of high quality and reliability. However, contact Hitachi's sales office before using the product in an application that demands especially high quality and reliability or where its failure or malfunction may directly threaten human life or cause risk of bodily injury, such as aerospace, aeronautics, nuclear power, combustion control, transportation, traffic, safety equipment or medical equipment for life support.
4. Design your application so that the product is used within the ranges guaranteed by Hitachi particularly for maximum rating, operating supply voltage range, heat radiation characteristics, installation conditions and other characteristics. Hitachi bears no responsibility for failure or damage when used beyond the guaranteed ranges. Even within the guaranteed ranges, consider normally foreseeable failure rates or failure modes in semiconductor devices and employ systemic measures such as fail-safes, so that the equipment incorporating Hitachi product does not cause bodily injury, fire or other consequential damage due to operation of the Hitachi product.
5. This product is not designed to be radiation resistant.
6. No one is permitted to reproduce or duplicate, in any form, the whole or part of this document without

written approval from Hitachi.

7. Contact Hitachi's sales office for any questions regarding this document or Hitachi semiconductor products.

---

---

# HITACHI

## Hitachi, Ltd.

Semiconductor & Integrated Circuits.

Nippon Bldg., 2-6-2, Ohte-machi, Chiyoda-ku, Tokyo 100-0004, Japan

Tel: Tokyo (03) 3270-2111 Fax: (03) 3270-5109

URL	NorthAmerica	: <a href="http://semiconductor.hitachi.com/">http://semiconductor.hitachi.com/</a>
	Europe	: <a href="http://www.hitachi-eu.com/hel/ecg">http://www.hitachi-eu.com/hel/ecg</a>
	Asia (Singapore)	: <a href="http://www.has.hitachi.com.sg/grp3/sicd/index.htm">http://www.has.hitachi.com.sg/grp3/sicd/index.htm</a>
	Asia (Taiwan)	: <a href="http://www.hitachi.com.tw/E/Product/SICD_Frame.htm">http://www.hitachi.com.tw/E/Product/SICD_Frame.htm</a>
	Asia (HongKong)	: <a href="http://www.hitachi.com.hk/eng/bo/grp3/index.htm">http://www.hitachi.com.hk/eng/bo/grp3/index.htm</a>
	Japan	: <a href="http://www.hitachi.co.jp/Sicd/indx.htm">http://www.hitachi.co.jp/Sicd/indx.htm</a>

### For further information write to:

Hitachi Semiconductor  
(America) Inc.  
179 East Tasman Drive,  
San Jose, CA 95134  
Tel: <1> (408) 433-1990  
Fax: <1> (408) 433-0223

Hitachi Europe GmbH  
Electronic components Group  
Dornacher StraÙe 3  
D-85622 Feldkirchen, Munich  
Germany  
Tel: <49> (89) 9 9180-0  
Fax: <49> (89) 9 29 30 00

Hitachi Europe Ltd.  
Electronic Components Group.  
Whitebrook Park  
Lower Cookham Road  
Maidenhead  
Berkshire SL6 8YA, United Kingdom  
Tel: <44> (1628) 585000  
Fax: <44> (1628) 778322

Hitachi Asia Pte. Ltd.  
16 Collyer Quay #20-00  
Hitachi Tower  
Singapore 049318  
Tel: 535-2100  
Fax: 535-1533

Hitachi Asia Ltd.  
Taipei Branch Office  
3F, Hung Kuo Building, No.167,  
Tun-Hwa North Road, Taipei (105)  
Tel: <886> (2) 2718-3666  
Fax: <886> (2) 2718-8180

Hitachi Asia (Hong Kong) Ltd.  
Group III (Electronic Components)  
7/F., North Tower, World Finance Centre,  
Harbour City, Canton Road, Tsim Sha Tsui,  
Kowloon, Hong Kong  
Tel: <852> (2) 735 9218  
Fax: <852> (2) 730 0281  
Telex: 40815 HITEC HX

Copyright © Hitachi, Ltd., 1998. All rights reserved. Printed in Japan.

**Revision Record**

<b>Rev. Date</b>	<b>Contents of Modification</b>	<b>Drawn by</b>	<b>Approved by</b>
0.0	Oct. 30, 1998	Initial issue	

---