



MULTIFUNCTION AUDIO PROCESSOR

CASSETTE PREAMPLIFIER:

- FORWARD/REVERSE INPUTS GROUND COMPATIBLE
- INTERNAL SWITCHES FOR EQUALIZATION
- INTERNAL ADJUSTMENT FOR TRAKING
- INTERNAL ADJUSTMENT FOR OUTPUT

AMS:

- INPUT GAIN CONTROL
- ADJUSTABLE GAIN VERSUS FREQUENCY

AUDIOPROCESSOR:

- INPUTS: 1 FULLY DIFFERENTIAL, 1 DIFFERENTIAL, 1 STEREO AND 1 MONO
- INPUT GAIN FROM 0 TO 15dB (1dB STEP)
- VOLUME CONTROL FROM +16 TO -63dB (1dB STEP)
- BASS AND TREBLE CONTROL FROM -18 TO 18dB (1dB STEP)
- DIRECT MUTE, SOFT MUTE AND RADIO MUTE
- FOUR INDEPENDENT OUTPUT STAGES:
 - ATTENUATION CONTROL FROM 0 TO -79dB (1dB STEP)
 - BEEP CONTROL (ON/OFF, FRONT/REAR)

STEREO DECODER:

- ROLL-OFF ADJUSTMENT
- SELECTABLE DEEMPHASIS
- 19KHz CANCELLATION
- HIGH CUT CONTROL
- STEREO BLEND

NOISE BLANKER

- AUTOMATIC THRESHOLD CONTROL AND PROGRAMMABLE TRIGGER THRESHOLD
- INTEGRATED HIGH PASS FILTER
- PACKAGE: TQFP64 (14x14)

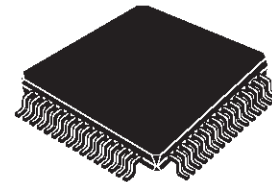

TQFP 64 (14x14)

ORDERING NUMBER: TDA7420

DESCRIPTION

The TDA7420 I²C bus controlled multifunction audio processor contains all signal processing blocks of a high performance car radio, including audioprocessor, stereodecoder, noise blanker, different mute functions, cassette preamplifier and AMS function.

The use of BICMOS technology allows the implementation of several filter functions with switched capacitor techniques like fully integrated, adjustment free PLL Loop filter, pilot detector with integrator.

This minimizes the number of external components.

Due to a highly linear signal processing, using CMOS-switching techniques instead of standard bipolar multipliers, very low distortion and very low noise are obtained also in the stereodecoder part.

Very low DC stepping is obtained by use of the BICMOS technology.

TDA7420

ABSOLUTE MAXIMUM RATINGS

Symbol	Parameter	Value	Unit
V _s	Operating Supply Voltage	10	V
T _{amb}	Operating Temperature Range	-40 to 85	°C
T _{stg}	Storage Temperature Range	-55 to 150	°C

PIN CONNECTION

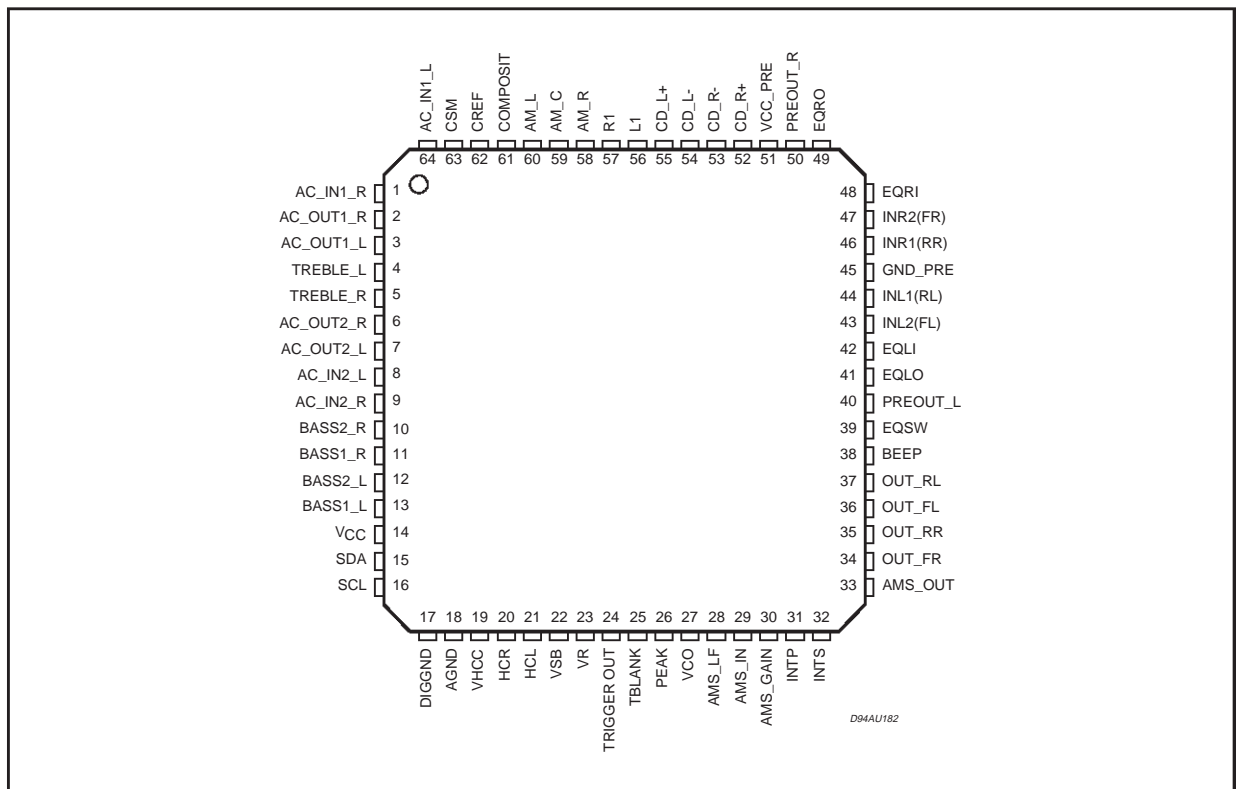

THERMAL DATA

Symbol	Parameter	Value	Unit
R _{th j-pins}	Thermal Resistance Junction-pins	max 85	°C/W

BLOCK DIAGRAM

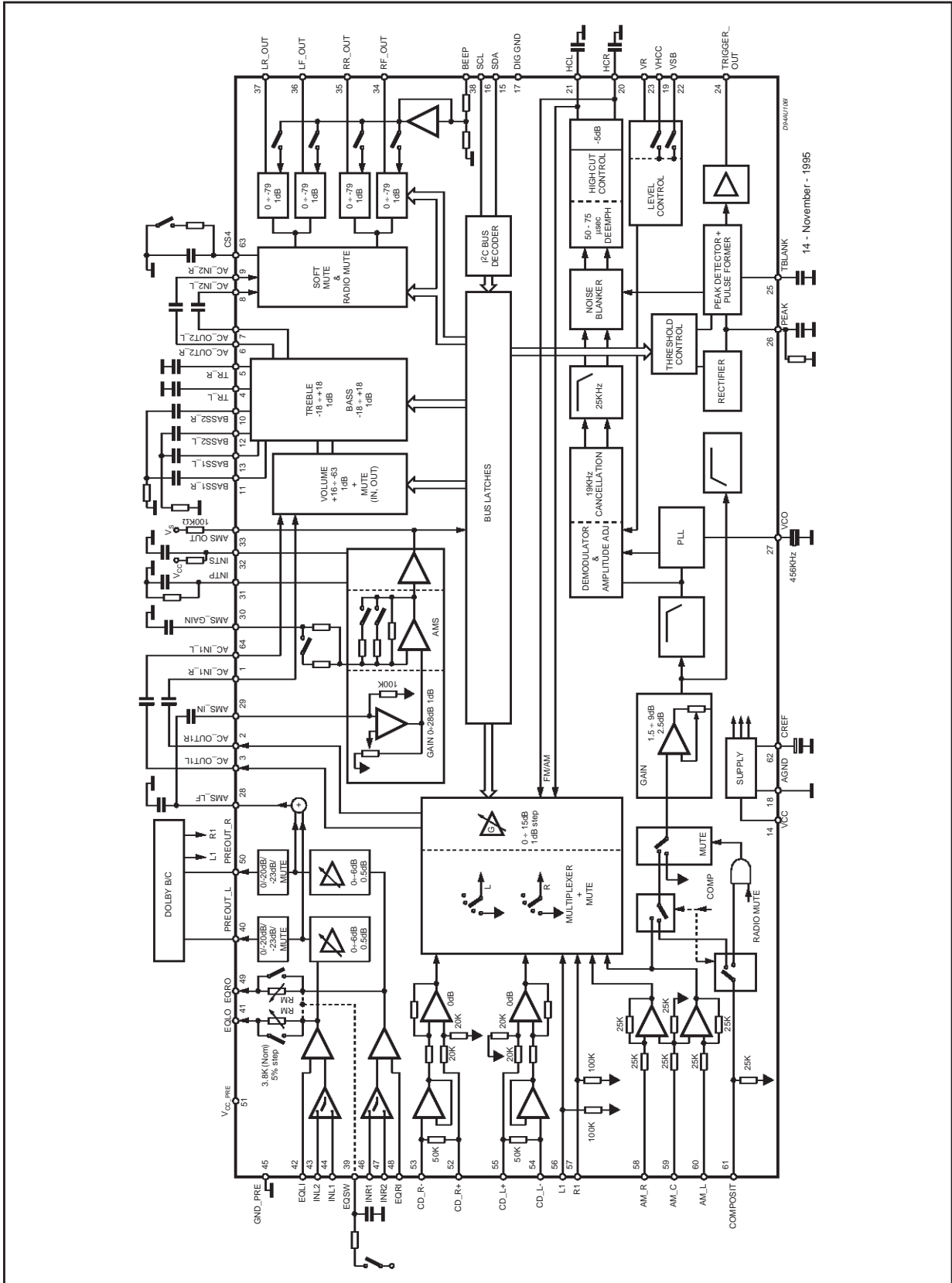

TDA7420

ELECTRICAL CHARACTERISTICS ($V_s = 8.5V$; $T_{amb} = 25^\circ C$; $R_L = 10K\Omega$; all gains = 0dB; $f = 1KHz$; unless otherwise specified, refer to the Test Circuit.)

Symbol	Parameter	Test Condition	Min.	Typ.	Max.	Unit
INPUT SECTION						
Differential Input Pins 52, 53, 54, 55						
R_I	Input Resistance		37	50	63	$K\Omega$
V_{CL}	Clipping Level	THD = 0.3%	2.0	2.5		V _{rms}
CMRR	Common Mode Rejection Ratio		45	55		dB
G_{DIFF}	Differential Gain		-1	0	1	dB
Stereo Input Pins 56, 57						
R_I	Input Resistance		75	100	125	$K\Omega$
V_{CL}	Clipping Level		2.0	2.5		V _{rms}
Quasi Differential Input Pins 58, 59, 60						
R_I	Input Resistance		18	25	32	$K\Omega$
V_{CL}	Clipping Level		2.0	2.5		V _{rms}
Composite Input Pin 61						
R_I	Input Resistance		18	25	32	$K\Omega$
V_{CL}	Clipping Level		2.0	2.5		V _{rms}
MULTIPLEXER						
R_O	Output Resistance (pin 2,3)		100	200	300	Ω
G_{MIN}	Minimum Gain		-1	0	1	dB
G_{MAX}	Maximum Gain		14	15	16	dB
G_{STEP}	Step Resolution		0.5	1	1.5	dB
V_{DC}	Dc Steps	Adjacent Gain Step	-5	1	5	mV
		G_{MIN} to G_{MAX}		2		mV
VOLUME CONTROL						
R_I	Input Resistance (1, 64)		24	33	42	$K\Omega$
C_{MAX}	Max Gain		15	16	17	dB
A_{MAX}	Max Attenuation			63		dB
A_{STEP}	Step Resolution Coarse Attenuation	$A_V = 16$ to -40 dB	0.5	1.0	1.5	dB
E_A	Attenuation Set Error	$G = 16$ to -40 dB	-1.5	0	1.5	dB
E_T	Tracking Error				2	dB
V_{DC}	DC Steps	Adjacent Attenuation Steps	-3	0.1	3	mV
		from 0dB to A_{MAX}		0.5	5	mV
SOFT MUTE						
A_{MUTE}	Mute Attenuation		40	50		dB
t_D	Delay Time	$C_{EXT} = 22nF$; 0 to -20 dB;		1.0		ms
		$I = I_{MAX}$ $I = I_{MIN}$		23		ms
BASS CONTROL						
C_{RANGE}	Control Range		± 15	± 18	± 20	dB
A_{STEP}	Step Resolution		0.5	1	1.5	dB
R_B	Internal Feedback Resistance		48	65	82	$K\Omega$

ELECTRICAL CHARACTERISTICS (continued.)

Symbol	Parameter	Test Condition	Min.	Typ.	Max.	Unit
TREBLE CONTROL						
C _{RANGE}	Control Range		±17	±18	±19	dB
A _{STEP}	Step Resolution		0.5	1	1.5	dB
R _T	Internal Feedback Resistance		37	50	63	KΩ
SPEAKER ATTENUATORS						
C _{RANGE}	Control Range			79		dB
A _{STEP}	Step Resolution	A _V = 0 to -40dB	0.5	1	1.5	dB
A _{MUTE}	Output Mute Attenuation		80	100		dB
E _A	Attenuation Set Error	A _V = 0 to -40dB			1.50	dB
V _{DC}	DC Step	Adjacent Attenuation Steps		0.1	3	mV
AUDIO OUTPUTS						
V _{CLIP}	Clipping Level	d = 0.3%	2.0	2.5		V _{RMS}
R _L	Output Load Resistance		2			KΩ
R _{OUT}	Output Impedance		100	200	300	Ω
V _{DC}	DC Voltage Level		3.35	3.6	3.85	V
GENERAL						
E _{NO}	Output Noise	BW = 20Hz to 20KHz, flat Output Muted All gains = 0dB		4.0 5.0	15	μV μV
S/N	Signal to Noise Ratio	All gains 0dB; V _O = 1V _{RMS} ;		106		dB
d	Distortion	V _I = 1V _{RMS} ;		0.01	0.08	%
S _C	Channel Separation Left/Right		80	95		dB
E _T	Total Tracking Error	A _V = 0 to -20dB; A _V = -20 to -40dB;		0	1	dB
				0	2	dB
BUS INPUT						
V _{IL}	Input Low Voltage				1	V
V _{IH}	Input High Voltage		3			V
I _{IN}	Input Current	V _{IN} = 0.4V	-5		5	μA
V _O	Output Voltage SDA Acknowledge	I _O = 1.6mA		0.1	0.4	V
SUPPLY						
V _{IL}	Supply Voltage		6.5	8.5	10.0	V
I _S	Supply Current	Stereo Decoder = ON	25	33	41	mA
		Stereo Decoder = OFF	20	28	35	mA
SVR	Ripple Rejection C _{ref} = 22μF	Audioprocessor		80		dB
		Stereo Decoder + Audioprocessor		60		dB

PREAMPLIFIER ($V_s = 8.5V$; $T_{amb} = 25^\circ C$; $R_{IN} = 600\Omega$; unless otherwise specified (see test circuit))

Symbol	Parameter	Test Condition	Min.	Typ.	Max.	Unit
R_I	Input Resistance		100			$K\Omega$
$V_{out DC}$	Output Voltage DC (pin 40, 50)		3.2	3.5	3.9	V
R_O	Output Resistance (pins 40, 50)		100	200	300	Ω
I_i	Input Bias Current				10	μA
G_{VO}	Open Loop Gain	$f = 400Hz$		110		dB
G_V	Closed Loop Gain	NAB short	31	32.5	34	dB
R_N	Resistance Normal Position		50	250	500	Ω
R_{MLR}	Resistance Metal Position (left ,right)		2.85	3.8	4.75	$K\Omega$
R_{MR}	Step Resolution (versus R_M)			5		%
R_{Mmax}	Maximum Value for R_M		3.42	4.56	5.7	$K\Omega$
R_{Mmin}	Minimum Value for R_M		2.28	3.04	3.8	$K\Omega$
	Dolby Level Control	Control Range	5.5	6.0	6.5	dB
		Step Resolution	0.25	0.5	0.75	dB
S_R	Slew Rate	NAB Short		1		$V/\mu s$
e_N	Total Input Noise	$R_{IN}=600\Omega$; unweighted		0.8		μV
		$R_{IN}=600\Omega$; CCIR warn		0.5		μV
		$R_{IN}=0$; unweighted		0.45		μV
	Output Attenuation Control	$D1, D0 = 00$	-0.75	0	0.75	dB
		$D1, D0 = 01$		-20		dB
		$D1, D0 = 10$		-23		dB
		$D1, D0 = 11$		-80		dB
THD	Total Harmonic Distortion	$V_O = 1V$; $f = 1KHz$ metal		0.02		%
		$V_O = 1V$; $f = 1KHz$ normal		0.02	0.1	%
		$V_O = 1V$; $f = 10KHz$ metal		0.05		%
		$V_O = 1V$; $f = 10KHz$ normal		0.04		%
		$V_O = 2V$; $f = 1KHz$				%
SVR_1	Ripple Rejection			75		dB
C_s	Channel Separation (L to R)		45	60		dB
C_{CT}	Channel Cross talk (F to R)		60	80		dB
S/N	Signal to Noise	$V_O = 388mV$; metal; CCIR arm		65		dB

AUDIO MUSIC SENSOR

I_{AMSOUT}	AMS Output Current				5	mA
V_{AMSOUT}	AMS Output Low Level	$I_{AMOUT} = 2mA$		500	800	mV
R_{i-29}	Input Resistance AMS Gain (pin 23)		75	100	125	$K\Omega$
V_{TH1}	Interprogram Threshold Voltage		1.2	1.45	1.7	V
V_{TH2}	Interspace Threshold Voltage		4.8	5.2	5.6	V
AMS_{th}	AMS Threshold Level		2.0	2.8	3.6	V
V_{INTP}	INTP Output Voltage	$I_{OUT} = 2mA$		0.2	0.8	mV
V_{INTS}	INTS Output Voltage	$I_{OUT} = 2mA$		0.2	0.8	mV
	INTP Charge Current		50	70	150	μA
	INTS Charge Current		50	70	150	μA
S_G	Gain Sensitivity	min Gain V_{30} vs V_{29}		11		dB
		max Gain V_{30} vs V_{29}		42		dB
R_{i-30}	AMS Gain Resistance	$D6, D5 = 00$	13	17.5	22	$K\Omega$
		$D6, D5 = 01$	16.5	22	27.5	$K\Omega$
		$D6, D5 = 11$	75	100	125	$K\Omega$

STEREO DECODER PART

ELECTRICAL CHARACTERISTICS ($V_S = 8.5V$; de-emphasis time: $T = 50\mu s$; nominal MPX input voltage on pin 61 (composite): $V_{MPX} = 0.5V_{RMS}$ (75KHz deviation); modulation frequency = 1KHz; $G_I = 1.5dB$; $T_{amb} = 27^\circ C$; unless otherwise specified)

Symbol	Parameter	Test Condition	Min.	Typ.	Max.	Unit
SVRR	Supply Voltage Ripple Rejection	$V_{RIPPLE} = 100mV$; $f = 1KHz$	50	65		dB
V_O	DC Output Voltage (HCL, HCR)		3.95	4.25	4.55	V
α	Channel Separation	$V_{SB} - V_R = 100mV_{DC}$		50		dB
THD	Total Harmonic Distortion			0.02	0.3	%
$\frac{S+N}{N}$	Signal Plus Noise to Noise Ratio	$f = 20Hz$ to $16KHz$; $S = 2V_{RMS}$		91		dB
MONO/STEREO SWITCH						
V_{INTH}	Pilot Threshold Voltage	for stereo "ON" $P_{th} = 1$ $P_{th} = 0$	12 19	16 26	22 34	mV_{RMS} mV_{RMS}
V_{INTH}	Pilot Threshold Voltage	for stereo "OFF" $P_{th} = 1$ $P_{th} = 0$	8 16	14 22	20 28	mV_{RMS} mV_{RMS}
STEREO BLEND						
V_{SB-VR}	Control Voltage for Channel Separation	$\alpha = 6dB$; (note 5)	-300	-250	-200	mV
		$\alpha = 26dB$;		-80		mV
HIGH CUT CONTROL						
τ_{deemp}	De-Emphasis Time Constant	$C_L, C_R = 1nF$; STDDS = 0 $V_{HCC} - V_R = 100mV$	43	50	57	μs
		$C_L, C_R = 1nF$; STDDS = 1 $V_{HCC} - V_R = 100mV$	64	75	86	μs
R_{HCC}	High Cut Control Resistance	$V_{HCC} - V_R = 100mV$; STDDS = 0	43	50	57	$K\Omega$
		$V_{HCC} - V_R = -0.5V$ (note 5)	115	150	185	$K\Omega$
VCO						
f_{OSC}	Oscillator Frequency			456		KHz
$\Delta f/f$	Capture and Hold Range		0.5	1		%
CARRIER AND HARMONIC SUPPRESSION AT THE OUTPUT						
α_{19}	Pilot Signal $f = 19KHz$		40	55		dB
α_{38}	Subcarrier $f = 38KHz$			75		dB
α_{57}	Subcarrier $f = 57KHz$			62		dB
α_{76}	Subcarrier $f = 76KHz$			90		dB
INTERMODULATION (note 1)						
α_2	$f_{mod} = 10KHz$; $f_{spur} = 1KHz$			65		dB
α_3	$f_{mod} = 13KHz$; $f_{spur} = 1KHz$			75		dB
TRAFFIC RADIO (note 2)						
α_{57}	Signal $f = 57KHz$			70		dB
SCA - SUBSIDIARY COMMUNICATIONS AUTHORIZATION (note 3)						
α_{67}	Signal $f = 67KHz$			75		dB
ACI - ADJACENT CHANNEL INTERFERENCE (note 4)						
α_{114}	Signal $f = 114KHz$			95		dB
α_{190}	Signal $f = 190KHz$			84		dB

NOTES TO THE CHARACTERISTICS

1 INTERMODULATION SUPPRESSION

$$\alpha_2 = \frac{V_{O(\text{signal})}(\text{at1KHz})}{V_{O(\text{spurious})}(\text{at1KHz})}; f_s = (2 \times 10\text{KHz}) - 19\text{KHz}$$

$$\alpha_3 = \frac{V_{O(\text{signal})}(\text{at1KHz})}{V_{O(\text{spurious})}(\text{at1KHz})}; f_s = (3 \times 13\text{KHz}) - 38\text{KHz}$$

measured with : 91% mono signal; 9% pilot signal; fm=10KHz or 13KHz.

2. TRAFFIC RADIO (V.F.) suppression

$$\alpha_{57}(\text{V.W.F.}) = \frac{V_{O(\text{signal})}(\text{at1KHz})}{V_{O(\text{spurious})}(\text{at1KHz} \pm 23\text{Hz})}$$

measured with : 91% stereo signal; 9% pilot signal; fm=1KHz; 5% subcarrier (f=57KHz, fm = 23Hz AM, m = 60%)

3. SCA (SUBSIDIARY COMMUNICATIONS AUTHORIZATION)

$$\alpha_{67} = \frac{V_{O(\text{signal})}(\text{at1KHz})}{V_{O(\text{spurious})}(\text{at9KHz})}; f_s = (2 \times 38\text{KHz}) - 67\text{KHz}$$

measured with : 81% mono signal; 9% pilot signal; fm=1KHz; 10% SCA - subcarrier (fs = 67KHz, unmodulated).

4. ACI (ADJACENT CHANNEL INTERFERENCE)

$$\alpha_{114} = \frac{V_{O(\text{signal})}(\text{at1KHz})}{V_{O(\text{spurious})}(\text{at4KHz})}; f_s = 110\text{KHz} - (3 \times 38\text{KHz})$$

$$\alpha_{190} = \frac{V_{O(\text{signal})}(\text{at1KHz})}{V_{O(\text{spurious})}(\text{at4KHz})}; f_s = 186\text{KHz} - (5 \times 38\text{KHz}) -$$

measured with 90% mono signal; 9% pilot signal; fm = 1KHz; 1% spurious signal (fs = 110KHz or 186KHz, unmodulated).

5: Control range for High Cut Control and Stereo Blend is $V_R - 400\text{mV} \leq V_{SB}, V_{HCC} \leq V_R$

Figure : High Cut Control

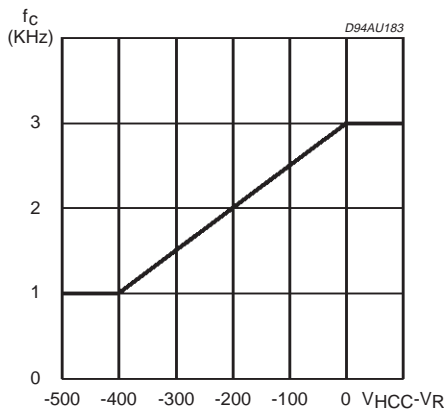
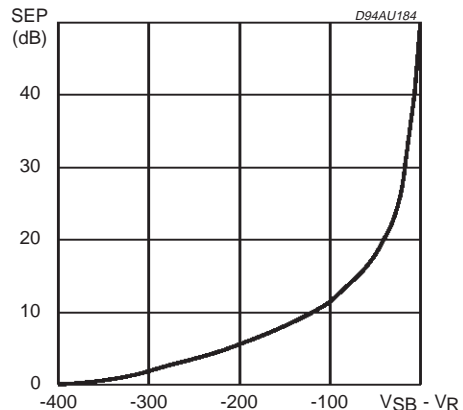

Figure : Stereo Blend



NOISE BLANKER PART FEATURES:

- INTERNAL 2nd ORDER 140KHz HIGH-PASS FILTER
- NOISE RECTIFIER OUTPUT FOR SIGNAL QUALITY DETECTION
- PROGRAMMABLE TRIGGER THRESHOLD
- TRIGGER THRESHOLD DEPENDENT ON HIGH FREQUENCY NOISE WITH PROGRAMMABLE GAIN
- ADDITIONAL CIRCUITS FOR DEVIATION AND FIELD STRENGTH -DEPENDENT TRIGGER ADJUSTMENT
- BLANKING TIME PROGRAMMABLE BY EXTERNAL CAPACITOR
- VERY LOW OFFSET CURRENT DURING HOLD TIME DUE TO OPAMPS WITH MOS INPUTS

ELECTRICAL CHARACTERISTICS (continued)

Symbol	Parameter	Test Condition		Min.	Typ.	Max.	Unit
V_{TRMIN}	Trigger Threshold (*) ¹⁾ minimum	Measured with NBT = 000 $V_{PEAK} = 1.2V$	D2 on byte 2 = 1 D2 on byte 2 = 0	100	150 30	200	mVp
V_{TRMIN}	Trigger Threshold ¹⁾ maximum	Measured with NBT = 111 $V_{PEAK} = 1.2V$	D2 on byte 2 = 1 D2 on byte 2 = 0	130	185 65	250	mVp
V_{TRSTEP}	Trigger Threshold Step Size				5		mVp
$V_{TRNOISE}$	Noise Adjusted Trigger Threshold ²⁾	Measured with $V_{PEAK} = 1.4V$ D2 on byte 2 = 0	NAT = 00 NAT = 01 NAT = 10 NAT = 11		140 180 240 280		mVp mVp mVp mVp
V_{PEAK}	Rectifier Voltage D2 on byte 2 = 1	$V_{MPX} = 0mV$			0.9		V
		$V_{MPX} = 50mV$ $f = 200KHz$			1.5		V
		$V_{MPX} = 100mV$ $f = 200KHz$			2.0		V
$V_{RECTDEV}$	Deviation Dependent Rectifier Voltage ³⁾	Measured with $V_{MPX} = 500mV$ (75KHz dev.)	OVD = 00(off) OVD = 01 OVD = 10 OVD = 11		0.9 1.2 2.0 2.8		V V V V
V_{RECTFS}	Field Strength Controlled Rectifier Voltage ⁴⁾	Measured with $V_{MPX} = 0mV$ $V_{SB}-V_R = -500mV$ (fully mono.)	FSC = 00(off) FSC = 01 FSC = 10 FSC = 11		0.9 1.3 1.9 2.4		V V V V
T_S	Suppression Pulse Duration	CBLANK = 330pF			40		μs
I_{OS}	Input Offset Current During Suppression Time				10		pA

(*) All thresholds are measured by using a pulse with $T_R = 2\mu s$, $T_{HIGH} = 2\mu s$ and $T_F = 10\mu s$.
The repetition rate must not increase the PEAK voltage.

- 1) NTB represents bits D0 - D2 of NB byte 1
- 2) NAT represents bits D3 - D4 of NB byte 1
- 3) OVD represents bits D5 - D6 of NB byte 1
- 4) FSC represents bits D0 - D1 of NB byte 2

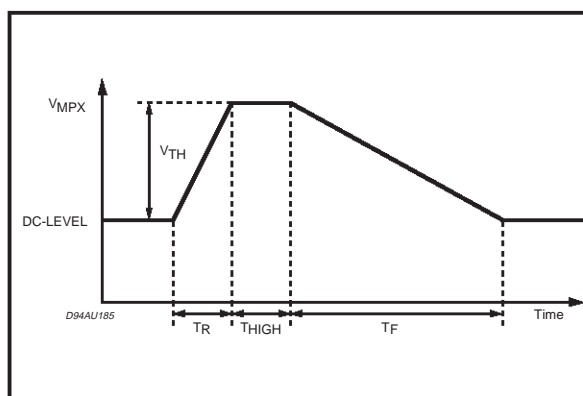

DESCRIPTION**DESCRIPTION OF THE NOISEBLANKER**

In the normal automotive environment the MPX signal is disturbed by ignition spikes, motors and high frequency switches etc.

The aim of the noiseblanker part is to cancel the influence of the spikes produced by these components.

Therefore the output of the stereodecoder is switched off for a time of 40µs (average spike duration).

In a first stage the spikes must be detected but to avoid a wrong triggering on high frequency noise a complex trigger control is implemented.

Behind the triggerstage a pulse former generates the 40µs "blanking" pulse.

In the following section all of these circuits are described in their function and their programming, too (see fig.1).

1.1 Normal Trigger Path (RECT-PEAK, ACT, PEAK-COMP, BLANK-COMP, BIAS-MONO)

The Incoming MPX signal is highpass-filtered, amplified and rectified (block RECT-PEAK).

The second order highpass-filter has a corner-frequency of 140KHz.

The gain of the rectifier can be controlled by the bit D2 of the noiseblanker byte2.

If programming bit D2 to zero the gain is only half of the nominal value.

All trigger thresholds must be roughly doubled in this case. The rectified signal, RECT, is used to generate by peak-rectification a signal called PEAK, which is available at the PEAK pin.

Also noise with a frequency >100KHz increases the PEAK voltage. The value of the PEAK voltage influences the trigger threshold voltage V_{th} (block ATC).

Both signals, RECT and PEAK+ V_{th} are fed to a comparator (block PEAK-COMP) which outputs a sawtooth-sharped waveform at the TBLANK pin, it is triggered.

A second comparator (block BLANK-COMP) forms the internal blanking duration of 40µs.

The noiseblanker is supplied by his own biasing circuit (block BIAS-MONO).

1.2 Automatic Threshold Control (ATC)

There are two independent possibilities for programming the trigger threshold:

- a) the minimum threshold in 8 steps (bits D0-D2,

NB-byte 1)

- b) the maximum threshold in 4 steps (bits D3-D4, NB-byte 1) (see fig.2)

The low threshold is used in combination with a good MPX signal without any noise.

The sensitivity in this operation is high, depending only on the programmed "Low Trigger Threshold", bits D0-D2 of the noiseblanker byte 1.

It is independent of the PEAK voltage.

The MPX signal is noisy (low fieldstrength) the PEAK signal increases due to the higher noise, which is also rectified (see part 1.1).

With increasing of the PEAK voltage the trigger threshold voltage increases, too. This particular gain is programmable in 4 steps (see fig.2).

1.3 Automatic Threshold Control by the Stereoblend voltage (ATC-SB)

Besides the noise controlled threshold adjustment there is an additional possibility for influencing the trigger.

It is controlled by the difference between V_{sb} and V_r , similar to the Stereoblend.

The reason for implementing such a second control will be explained in the following:

The point where the MPX signal starts to become noisy is fixed by the RF part.

Therefore also the starting point of the normal noise controlled trigger adjustment is fixed (fig.3).

But in some cases the behaviour of the noiseblanker can be improved by increasing the threshold even in a region of higher fieldstrength, for the MPX signal often shows distortion in this range.

Because of the overlap of this range and the range of the stereo/mono transition it can be controlled by V_{sb} and V_r .

This threshold increase is programmable in 3 steps or switched off (see fig.3).

1.4 Over Deviation Detector (MPX-RECT)

Sometimes when listening to stations with a higher deviation than 75KHz the noiseblanker triggers on the high frequency modulation.

To avoid this blanking, which causes noise in the output signal, the noiseblanker offers a deviation-dependent threshold adjustment.

By rectifying the MPX signal a further signal representing the actual deviation is obtained.

It is used to increase the PEAK voltage.

Offset and gain of this circuit are programmable in 3 steps (the first step turns off the detector, see fig.4).

Figure 1: Block Diagram of the Noise Blanker

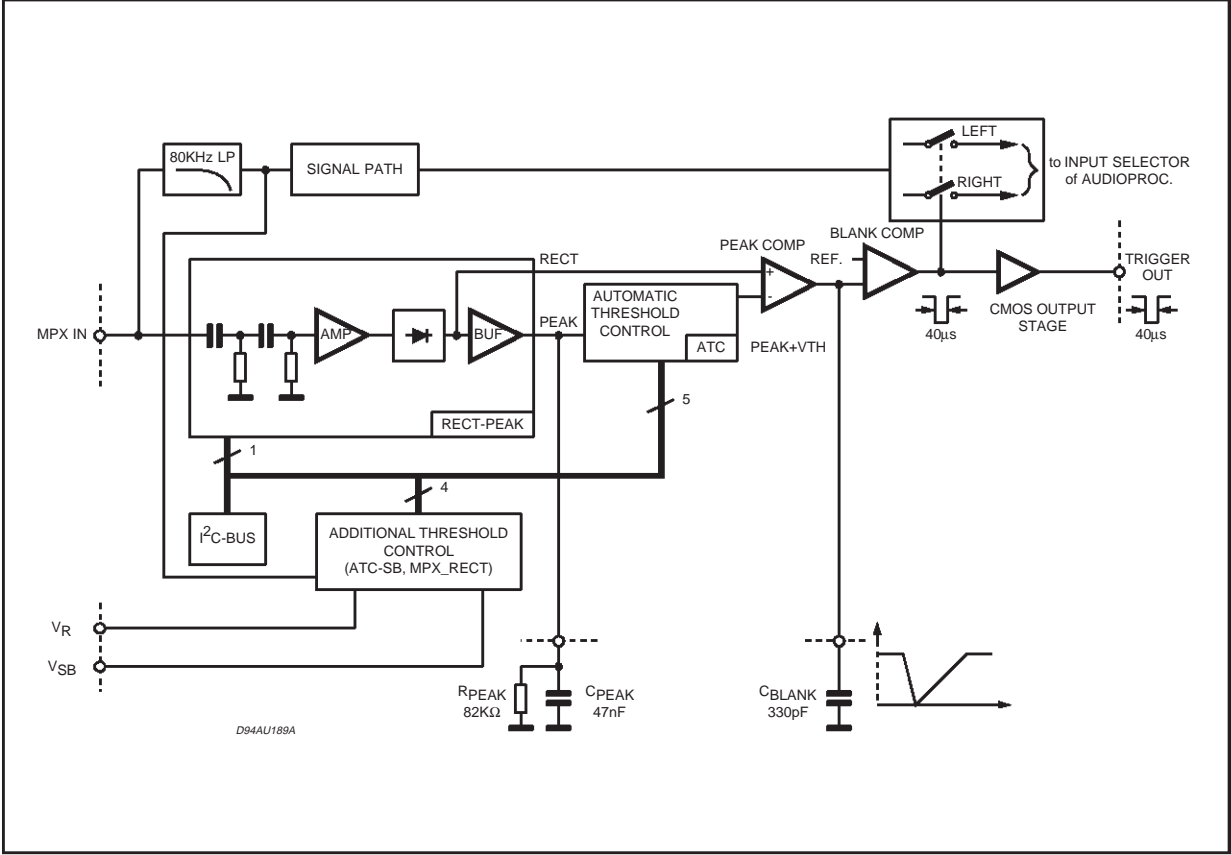

Figure 2: Trigger Threshold vs. V_{peak}

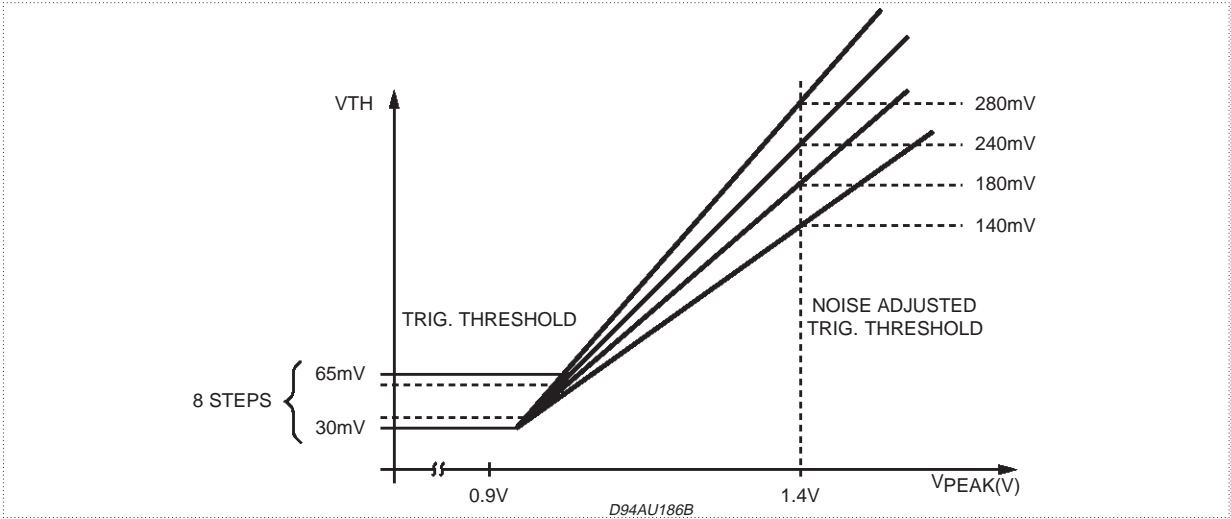

Figure 3: Behaviour of the Field Strength Controlled Threshold Adjustment

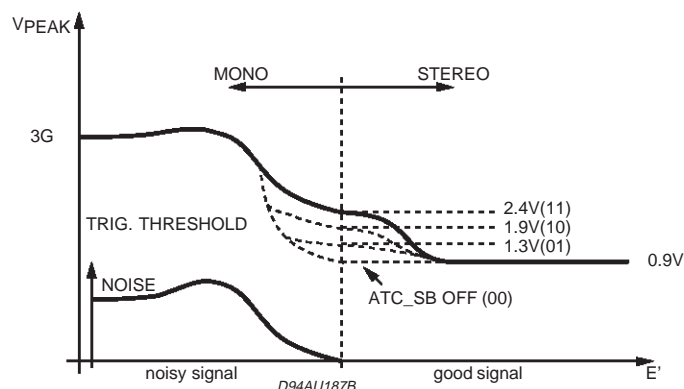
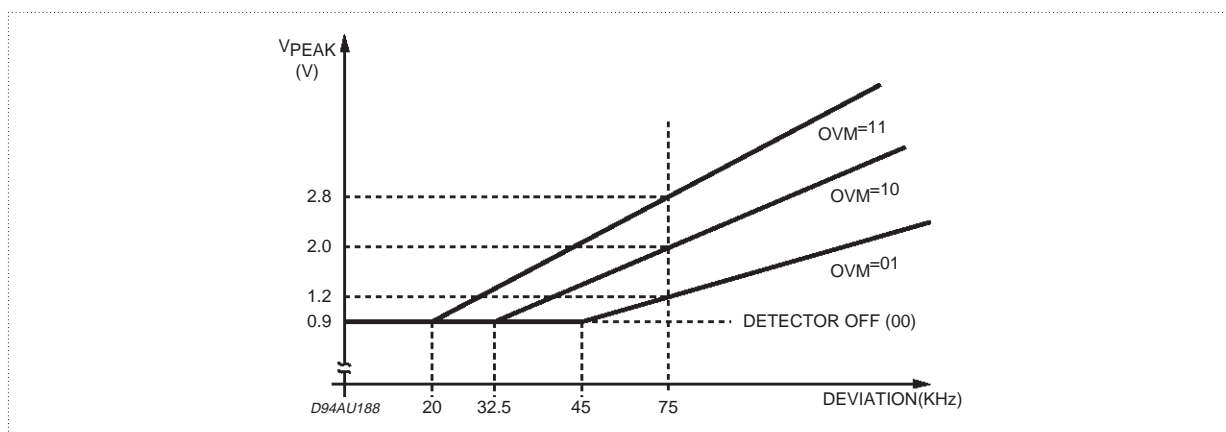

Figure 4: Behaviour of the Deviation Dependent Threshold Adjust (Over Deviation Detector)



I²C BUS INTERFACE
Interface Protocol

The interface protocol comprises:

- A start condition (s)
- A chip address byte, (the LSB bit determines read/write transmission).
- A subaddress byte
- A sequence of data (N-bytes + acknowledge)
- A stop condition (P)

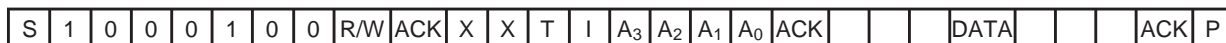
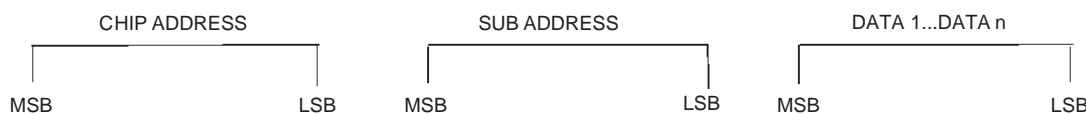

ACK = Acknowledge

S = Start

P = Stop

I = Autoincrement

MAX CLOCK SPEED 500kbits/s

Autoincrement

If bit I in the subaddress byte is set to "1", the autoincrement of subaddress is enabled.

TRANSMITTED DATA (SEND MODE)

MSB							LSB	
X	X	X	X	X	ST	SM	AMS	HIGH = Active

AMS = True Blank Detected

SM = Soft mute activated

ST = Stereo (HIGH = active)

SUBADDRESS (RECEIVE MODE)

MSB				LSB				FUNCTION
X	X	X	I	D ₃	D ₂	D ₁	D ₀	
				0	0	0	0	Mux
				0	0	0	1	Volume
				0	0	1	0	Treble
				0	0	1	1	Bass
				0	1	0	0	Speaker Attenuator LF
				0	1	0	1	Speaker Attenuator RF
				0	1	1	0	Speaker Attenuator LR
				0	1	1	1	Speaker Attenuator RR
				1	0	0	0	Mute & Beep
				1	0	0	1	Stereodecoder
				1	0	1	0	Noise Blanker 1
				1	0	1	1	Noise Blanker 2
				1	1	0	0	AMS
				1	1	0	1	Dolby Level Control
				1	1	1	0	Metal Resistance Control
				1	1	1	1	Preamplifier Attenuation

If bit in the subaddress byte is set to "1", the autoincrement of subaddress is enabled

INPUT SELECTOR

MSB				LSB				FUNCTION
D7	D6	D5	D4	D3	D2	D1	D0	
				0	0	0	0	Input Gain
				0	0	0	1	0dB
				0	0	1	0	1dB
				0	0	1	1	2dB
				0	1	0	0	3dB
				0	1	0	1	4dB
				0	1	1	0	5dB
				0	1	1	1	6dB
				1	0	0	0	7dB
				1	0	0	1	8dB
				1	0	1	0	9dB
				1	0	1	1	10dB
				1	1	0	0	11dB
				1	1	0	1	12dB
				1	1	1	0	13dB
				1	1	1	1	14dB
				1	1	1	1	15dB
	0	0	0					Full diff CD
	0	0	1					Stereo
	0	1	0					Stereo Decoder
	0	1	1					AM quasi diff input
	1	0	0					Quasi diff CD
	1	0	1					Not allowed
	1	1	0					Not allowed
	1	1	1					AM Mono (AM R input)

VOLUME

MSB				LSB				FUNCTION
D7	D6	D5	D4	D3	D2	D1	D0	
								-1 dB STEPS
					0	0	0	-0dB
					0	0	1	-1dB
					0	1	0	-2dB
					0	1	1	-3dB
					1	0	0	-4dB
					1	0	1	-5dB
					1	1	0	-6dB
					1	1	1	-7dB
								-8 dB STEPS
	0	0	0	0				16dB
	0	0	0	1				8dB
		0	1	0				0dB
		0	1	1				-8dB
		1	0	0				-16dB
		1	0	1				-24dB
		1	1	0				-32dB
		1	1	1				-40dB
	1	0	0	0				-48dB
	1	0	0	1				-56dB
1								Mute

TDA7420

TREBLE

MSB				LSB				FUNCTION
D7	D6	D5	D4	D3	D2	D1	D0	
		1	1	0	0	1	0	-18dB
		1	1	0	0	0	1	-17dB
		1	1	0	0	0	0	-16dB
		1	0	1	1	1	1	-15dB
		1	0	1	1	1	0	-14dB
		1	0	1	1	0	1	-13dB
		1	0	1	1	0	0	-12dB
		1	0	1	0	1	1	-11dB
		1	0	1	0	1	0	-10dB
		1	0	1	0	0	1	-9dB
		1	0	1	0	0	0	-8dB
		1	0	0	1	1	1	-7dB
		1	0	0	1	1	0	-6dB
		1	0	0	1	0	1	-5dB
		1	0	0	1	0	0	-4dB
		1	0	0	0	1	1	-3dB
		1	0	0	0	1	0	-2dB
		1	0	0	0	0	1	-1dB
		1	0	0	0	0	0	0dB
		0	0	0	0	0	0	0dB
		0	0	0	0	0	1	1dB
		0	0	0	0	1	0	2dB
		0	0	0	0	1	1	3dB
		0	0	0	1	0	0	4dB
		0	0	0	1	0	1	5dB
		0	0	0	1	1	0	6dB
		0	0	0	1	1	1	7dB
		0	0	1	0	0	0	8dB
		0	0	1	0	0	1	9dB
		0	0	1	0	1	0	10dB
		0	0	1	0	1	1	11dB
		0	0	1	1	0	0	12dB
		0	0	1	1	0	1	13dB
		0	0	1	1	1	0	14dB
		0	0	1	1	1	1	15dB
		0	1	0	0	0	0	16dB
		0	1	0	0	0	1	17dB
		0	1	0	0	1	0	18dB

BASS

MSB				LSB				FUNCTION
D7	D6	D5	D4	D3	D2	D1	D0	
		1	1	0	0	1	0	-18dB
		1	1	0	0	0	1	-17dB
		1	1	0	0	0	0	-16dB
		1	0	1	1	1	1	-15dB
		1	0	1	1	1	0	-14dB
		1	0	1	1	0	1	-13dB
		1	0	1	1	0	0	-12dB
		1	0	1	0	1	1	-11dB
		1	0	1	0	1	0	-10dB
		1	0	1	0	0	1	-9dB
		1	0	1	0	0	0	-8dB
		1	0	0	1	1	1	-7dB
		1	0	0	1	1	0	-6dB
		1	0	0	1	0	1	-5dB
		1	0	0	1	0	0	-4dB
		1	0	0	0	1	1	-3dB
		1	0	0	0	1	0	-2dB
		1	0	0	0	0	1	-1dB
		1	0	0	0	0	0	0dB
		0	0	0	0	0	0	0dB
		0	0	0	0	0	1	1dB
		0	0	0	0	1	0	2dB
		0	0	0	0	1	1	3dB
		0	0	0	1	0	0	4dB
		0	0	0	1	0	1	5dB
		0	0	0	1	1	0	6dB
		0	0	0	1	1	1	7dB
		0	0	1	0	0	0	8dB
		0	0	1	0	0	1	9dB
		0	0	1	0	1	0	10dB
		0	0	1	0	1	1	11dB
		0	0	1	1	0	0	12dB
		0	0	1	1	0	1	13dB
		0	0	1	1	1	0	14dB
		0	0	1	1	1	1	15dB
		0	1	0	0	0	0	16dB
		0	1	0	0	0	1	17dB
		0	1	0	0	1	0	18dB
	1							Non DC extended bass
	0							DC extended bass

SPEAKERS ATTENUATORS

MSB							LSB		LF, LR, RF, RR
D7	D6	D5	D4	D3	D2	D1	D0		
								-1dB STEPS	
					0	0	0	0dB	
					0	0	1	-1dB	
					0	1	0	-2dB	
					0	1	1	-3dB	
					1	0	0	-4dB	
					1	0	1	-5dB	
					1	1	0	-6dB	
					1	1	1	-7dB	
								8dB STEPS	
	0	0	0	0				0dB	
	0	0	0	1				-8dB	
	0	0	1	0				-16dB	
	0	0	1	1				-24dB	
	0	1	0	0				-32dB	
	0	1	0	1				-40dB	
	0	1	1	0				-48dB	
	0	1	1	1				-56dB	
	1	0	0	0				-64dB	
	1	0	0	1				-72dB	
	1	1	0					Mute	
	1	0	1						
	1	1	1						

MUTE & BEEP

MSB							LSB		FUNCTION
D7	D6	D5	D4	D3	D2	D1	D0		
							1	Soft Mute - FAST SLOPE	
							0	Soft Mute - Slow Slope	
						1		Soft Mute OFF	
						0		Soft Mute ON	
					0	0		Direct Input Mute ON	
					1	0		Direct Input Mute OFF	
				0		0		Radio Mute ON	
				1		0		Radio Mute OFF	
			1					Composit Input Enabled	
			0					Composit Mute Enabled	
		1						Beep ON - Front	
	1							Beep ON - Rear	
1								VCO OFF	
0								VCO ON	

STEREO DECODER

MSB							LSB		FUNCTION
D7	D6	D5	D4	D3	D2	D1	D0		
Input Gain									
						0	0	1.5dB Input Gain	
						0	1	4.0dB Input Gain	
						1	0	6.5dB Input Gain	
						1	1	9dB Input Gain	
Roll Off Adjustement									
			0	0	1			20.2%	
			0	1	0			21.9%	
			0	1	1			23.7%	
			1	0	0			25.5%	
			1	0	1			27.3%	
			1	1	0			29.2%	
			1	1	1			31%	
		0						Deemph. Time Constant 75 μ s	
		1						Deemph. Time Constant 50 μ s	
	1							Forced Mono	
	0							Stereo Enabled	
0								Pilot Threshold High	
1								Pilot Threshold Low	

NOISE BLANKER 1

MSB							LSB		FUNCTION
D7	D6	D5	D4	D3	D2	D1	D0		
Noise Blanker Threshold Vpeak = 0.9V									
					0	0	0	V _{th} = 30mV	
					0	0	1	V _{th} = 35mV	
					0	1	0	V _{th} = 40mV	
					0	1	1	V _{th} = 45mV	
					1	0	0	V _{th} = 50mV	
					1	0	1	V _{th} = 55mV	
					1	1	0	V _{th} = 60mV	
					1	1	1	V _{th} = 65mV	
Noise Blanker Noise Adjusted Threshold Vpeak = 1.4V									
			0	0				V _{th} = 140mV	
			0	1				V _{th} = 180mV	
			1	0				V _{th} = 240mV	
			1	1				V _{th} = 280mV	
Gain of Overdeviation Detector Vpeak with MPX of 75KHz Deviation									
	0	0						Detector Off	
	0	1						V _{peak} = 1.2Vop	
	1	0						V _{peak} = 2.0Vop	
	1	1						V _{peak} = 2.8Vop	

NOISE BLANKER 2

MSB							LSB		FUNCTION
D7	D6	D5	D4	D3	D2	D1	D0		
Field Strenght Controlled Rectifier Voltage (control by Vsb-Vr) Vpeak at Vsb-Vr = -500mV (fully Mono)									
						0	0	Control Off	
						0	1	Vpeak = 1.3V	
						1	0	Vpeak = 1.9V	
						1	1	Vpeak = 2.4V	
Noise Blanker Gain									
					1			Low	
					0			High	

AMS

MSB							LSB		FUNCTION
D7	D6	D5	D4	D3	D2	D1	D0		
Att. Sensitivity Tuning									
						0	0	0dB	
						0	1	-1dB	
						1	0	-2dB	
						1	1	-3dB	
Gain Sensitivity Tuning									
			0	0	0			0dB	
			0	0	1			10dB	
			0	1	0			14dB	
			0	1	1			18dB	
			1	0	0			22dB	
			1	0	1			26dB	
			1	1	0			30dB	
			1	1	1			34dB	
AC Sensitivity Tuning									
	0	0						22dB f = 1.1KHz SW1 = SW2 = SW3	
	0	1						34dB f = 1.1KHz	
	1	0						not allowed	
	1	1						21dB f = 160Hz	
0								AMS ON	
1								AMS OFF	

DOLBY LEVEL CONTROL

MSB				LSB				FUNCTION
D7	D6	D5	D4	D3	D2	D1	D0	
								Right Channel
				0	0	0	0	0dB
				0	0	0	1	-0.5dB
				0	0	1	0	-1.0dB
				0	0	1	1	-1.5dB
				0	1	0	0	-2.0dB
				0	1	0	1	-2.5dB
				0	1	1	0	-3.0dB
				0	1	1	1	-3.5dB
				1	0	0	0	-4.0dB
				1	0	0	1	-4.5dB
				1	0	1	0	-5.0dB
				1	0	1	1	-5.5dB
				1	1	X	X	-6.0dB
								Left Channel
0	0	0	0					-0dB
0	0	0	1					-0.5dB
0	0	1	0					-1.0dB
0	0	1	1					-1.5dB
0	1	0	0					-2.0dB
0	1	0	1					-2.5dB
0	1	1	0					-3.0dB
0	1	1	1					-3.5dB
1	0	0	0					-4.0dB
1	0	0	1					-4.5dB
1	0	1	0					-5.0dB
1	0	1	1					-5.5dB
1	1	X	X					-6.0dB

METAL RESISTANCE CONTROL

MSB				LSB				FUNCTION
D7	D6	D5	D4	D3	D2	D1	D0	
								Right Channel
				1	0	0	0	R metal +20%
				0	0	0	0	R metal +15%
				0	0	0	1	R metal +10%
				0	0	1	0	R metal +5%
				0	0	1	1	R metal =3.8K Ω Typical
				0	1	0	0	R metal - 5%
				0	1	0	1	R metal - 10%
				0	1	1	0	R metal - 15%
				0	1	1	1	R metal - 20%
								Left Channel
1	0	0	0					R metal +20%
0	0	0	0					R metal +15%
0	0	0	1					R metal +10%
0	0	1	0					R metal +5%
0	0	1	1					R metal =3.8K Ω Typical
0	1	0	0					R metal - 5%
0	1	0	1					R metal - 10%
0	1	1	0					R metal - 15%
0	1	1	1					R metal - 20%

PREAMPLIFIER

MSB				LSB				FUNCTION
D7	D6	D5	D4	D3	D2	D1	D0	
								Attenuation control
						0	0	0dB
						0	1	-20dB
						1	0	-23dB
						1	1	Mute
					0			Reverse Mode On
					1			Forward Mode On

PINS: 1, 64

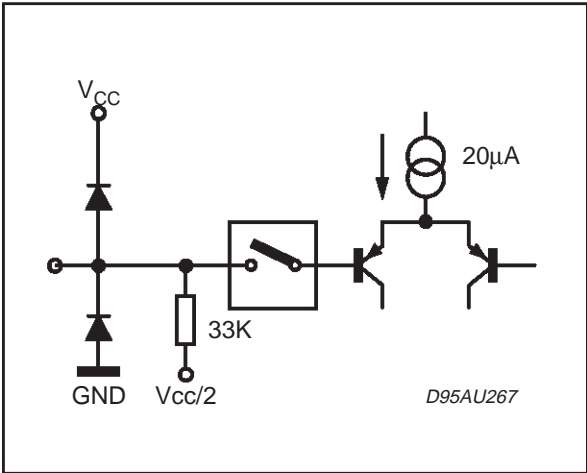

PINS: 2, 3, 6, 7,

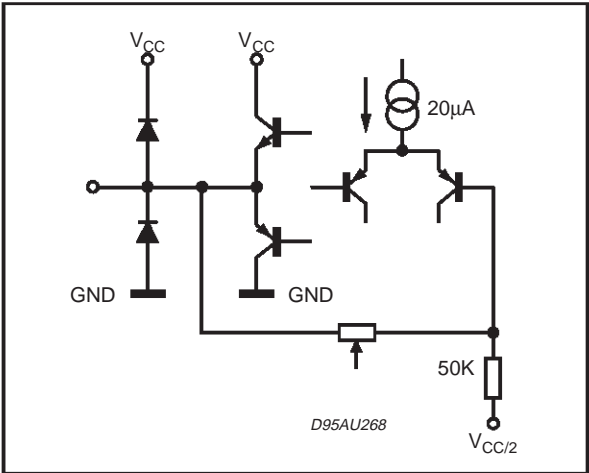

PINS: 40, 50

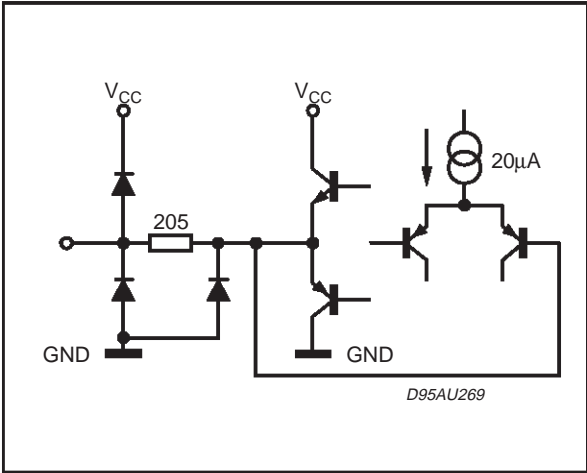

PINS: 8, 9

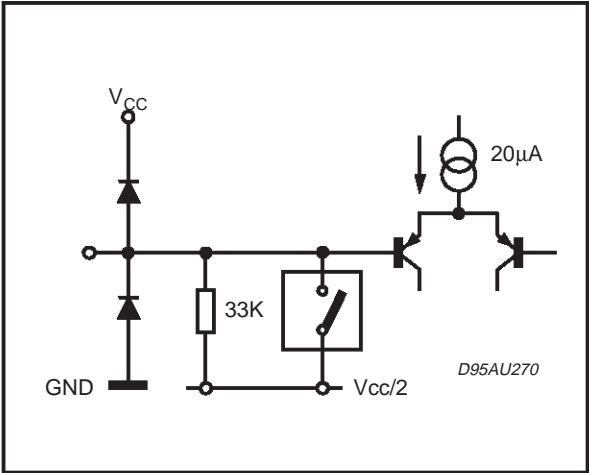

PINS: 10, 12

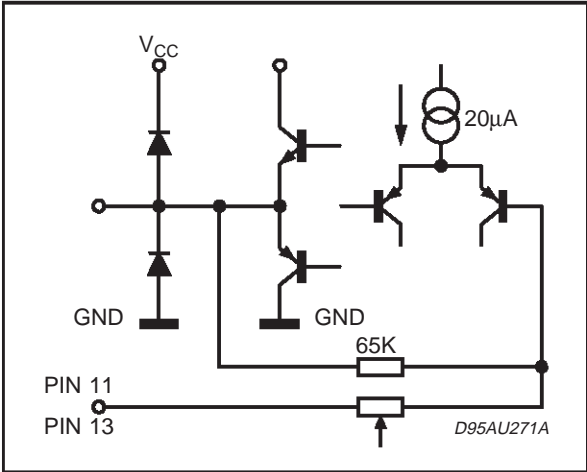

PINS: 11, 13

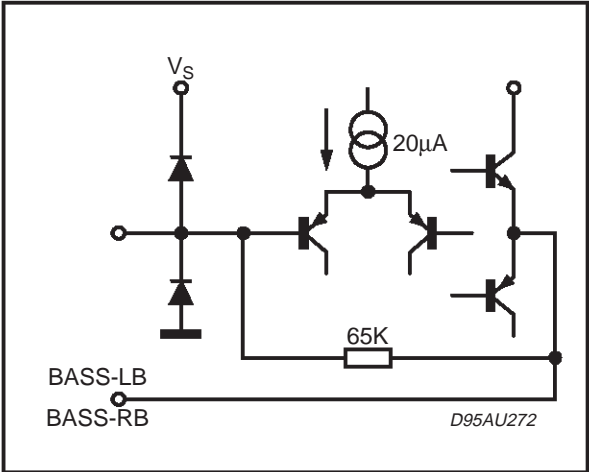

PIN: 15

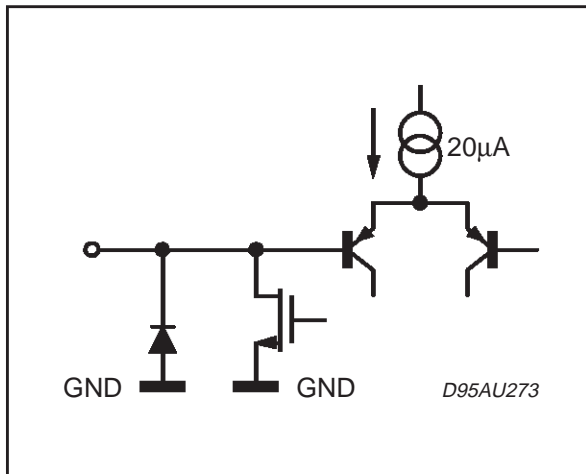

PIN: 16

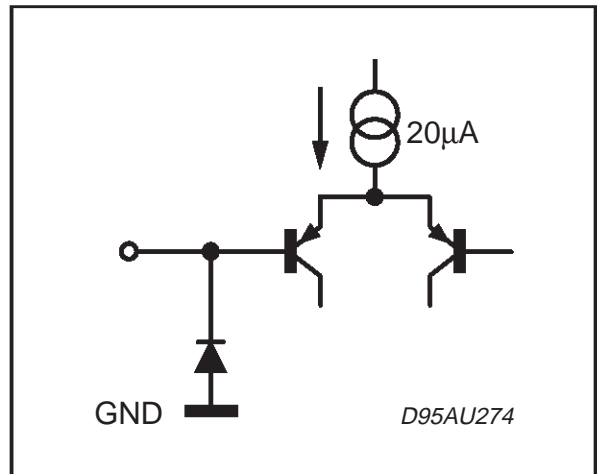

PIN: 19

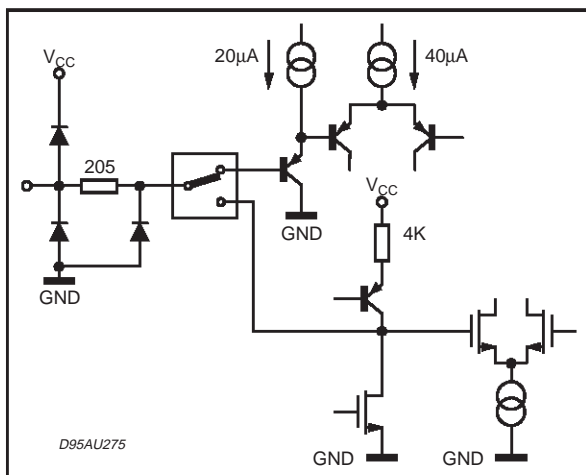

PINS: 20, 21

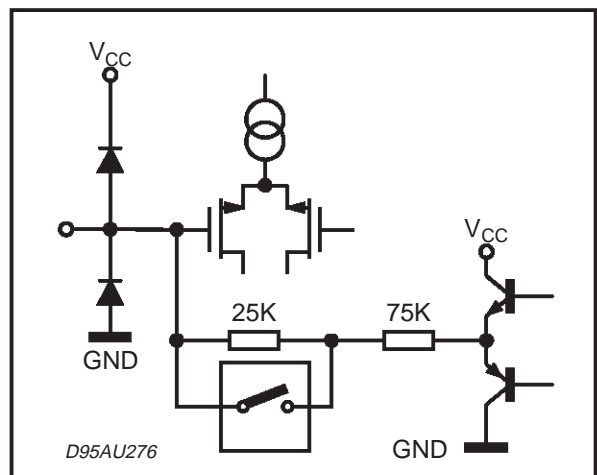

PIN: 22

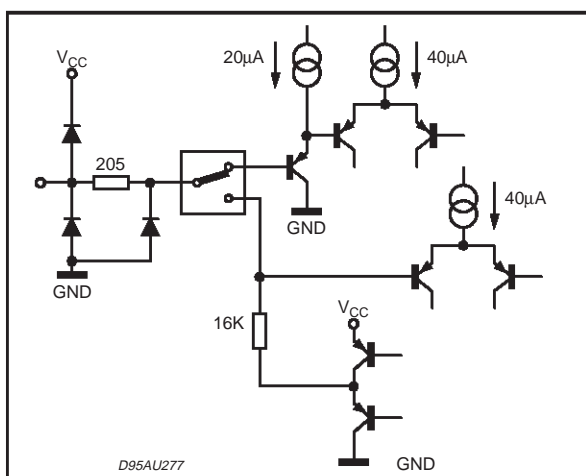

PIN: 23

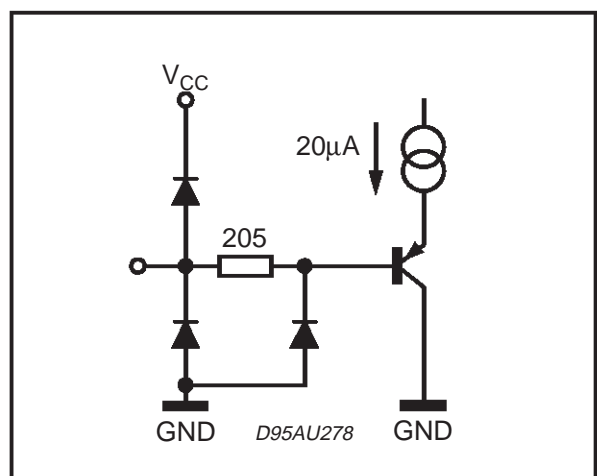

PIN: 24

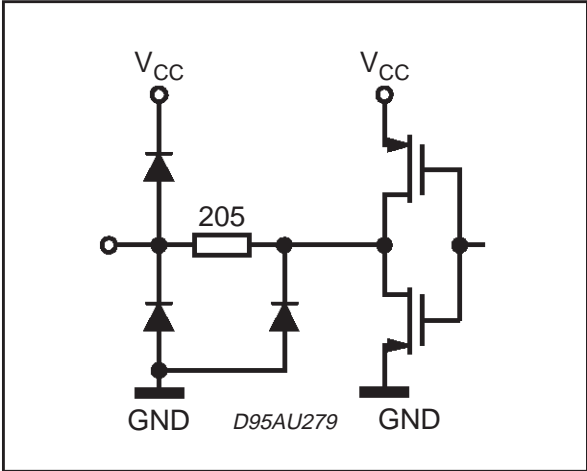

PIN: 25

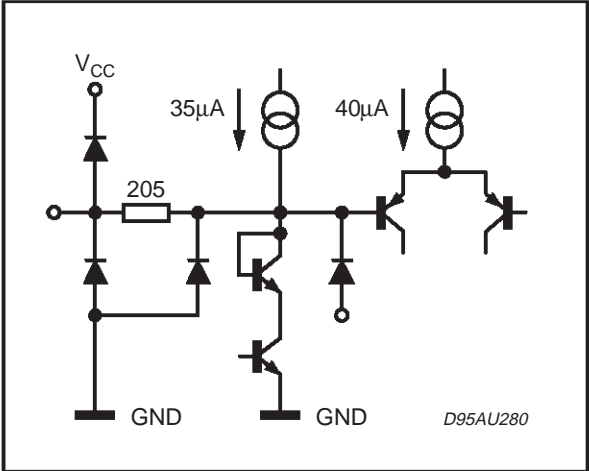

PIN: 26

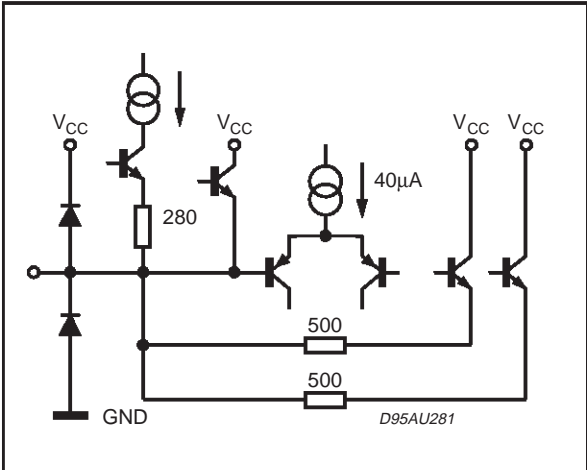

PIN: 27

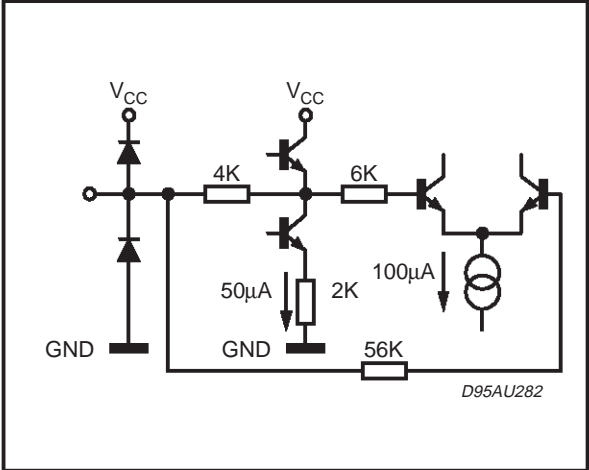

PIN: 28

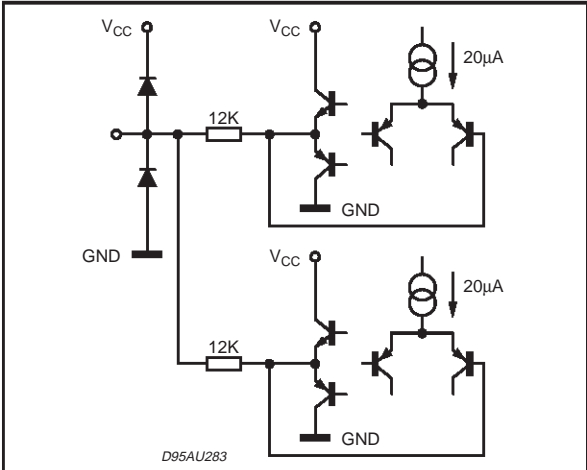

PINS: 29, 56, 57

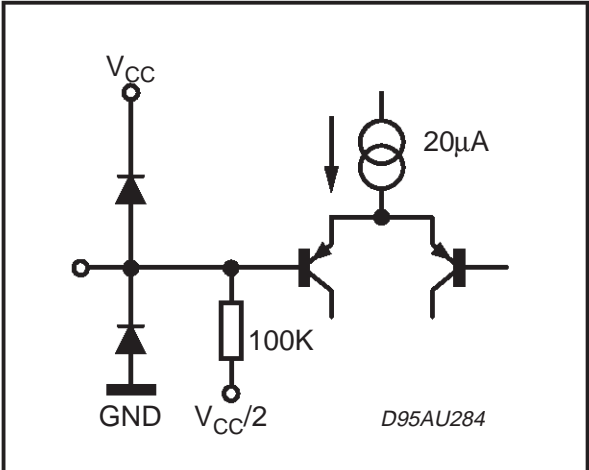

TDA7420

PIN: 30

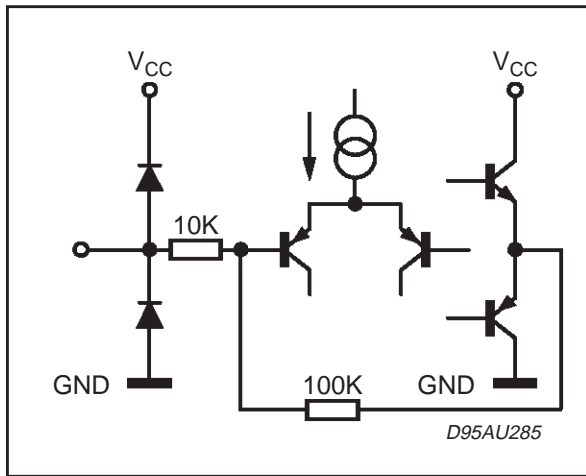

PIN: 31

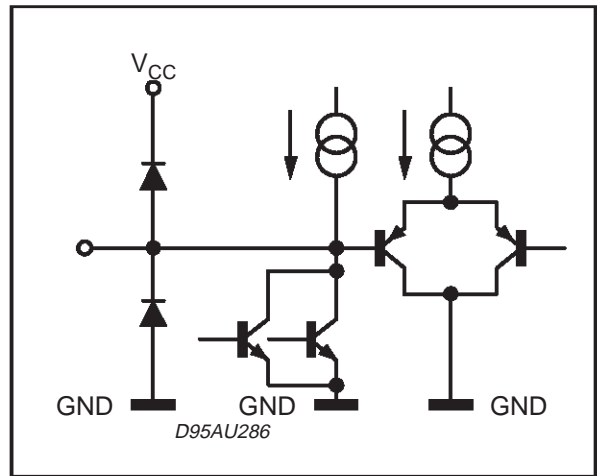

PIN: 32

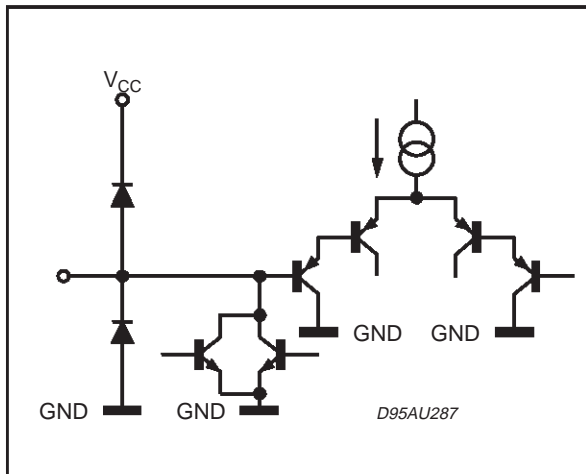

PIN: 33

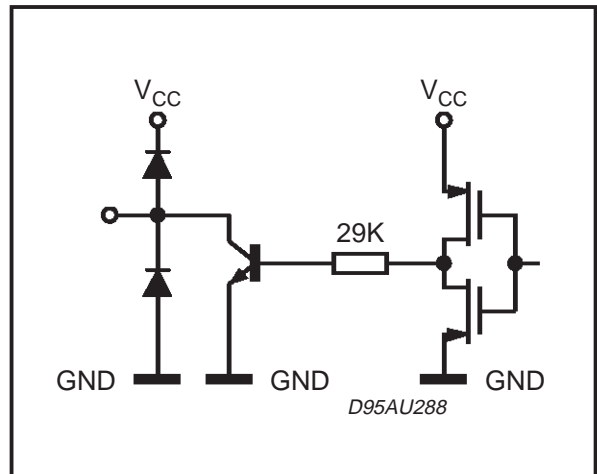

PINS: 34, 35, 36, 37

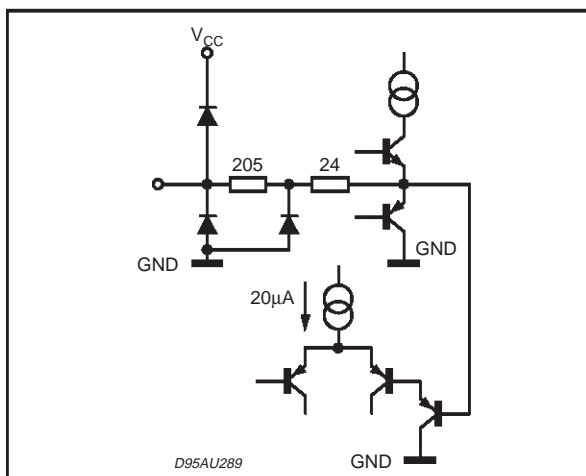

PINS: 38

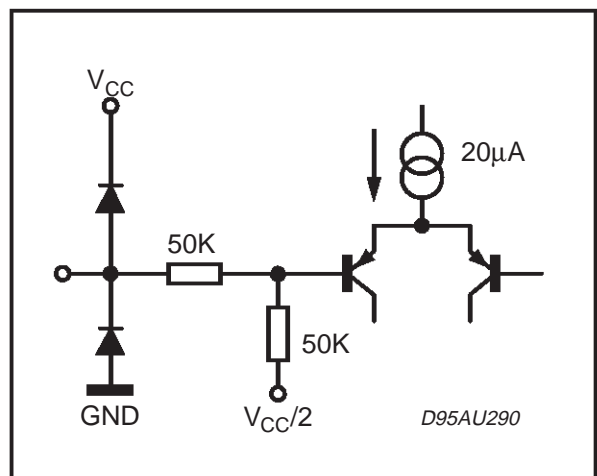

PINS: 39

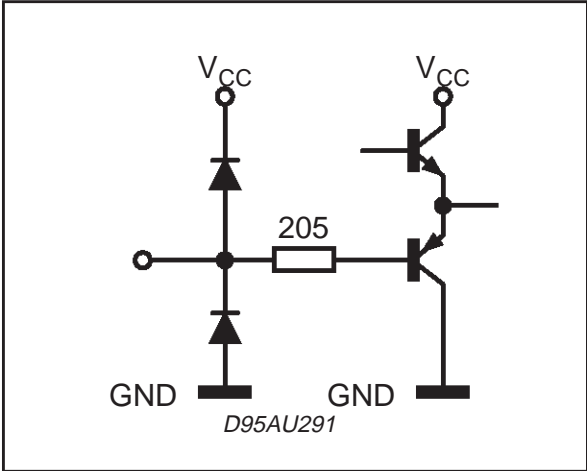

PINS: 41,49

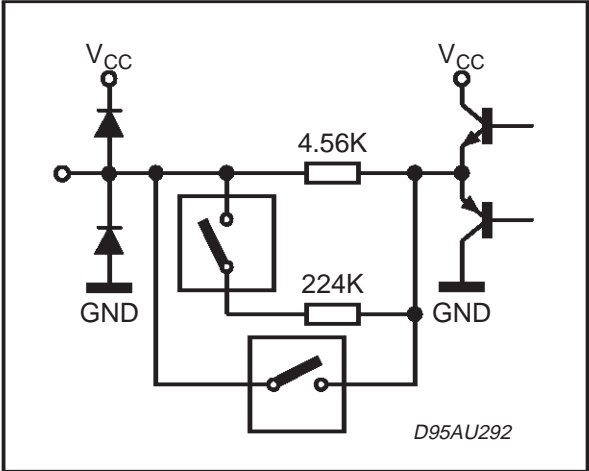

PINS: 42, 48

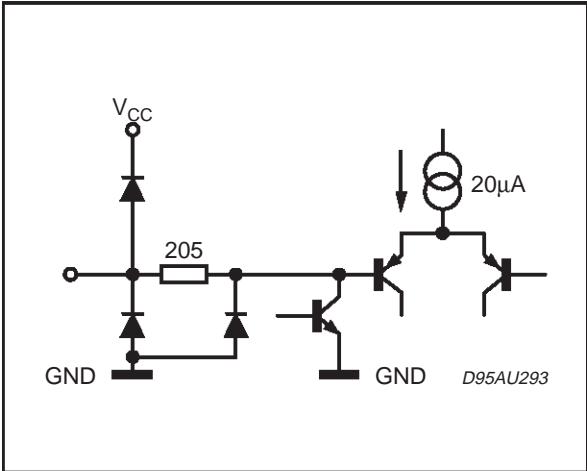

PINS: 43, 44, 46, 47

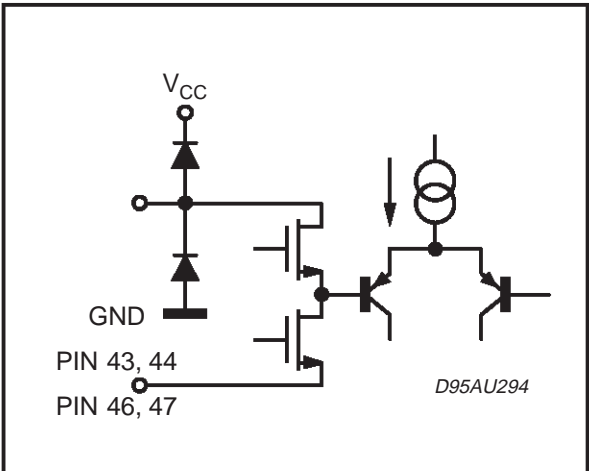

PINS: 52, 53

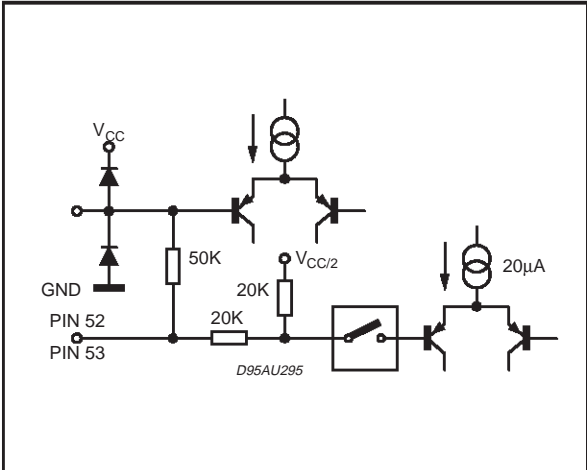

PINS: 54, 55

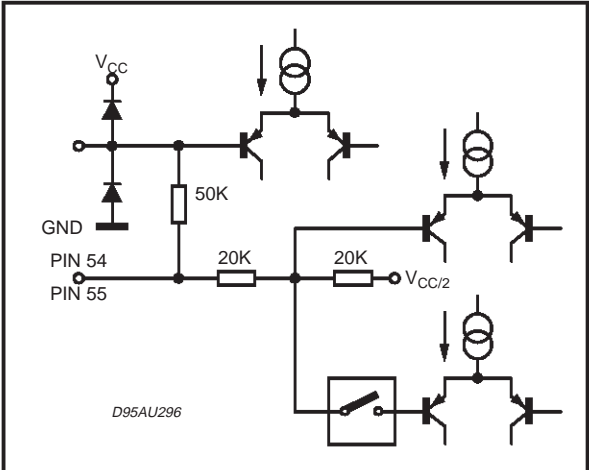

PINS: 58, 60

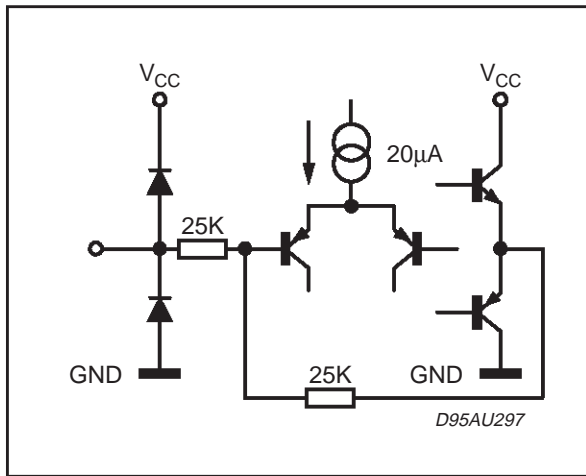

PIN: 59

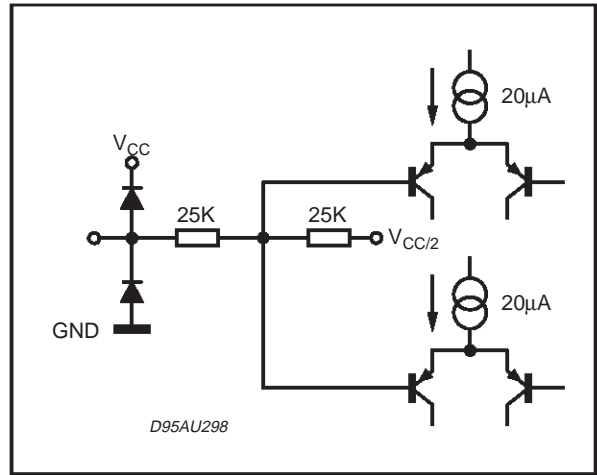

PIN: 61

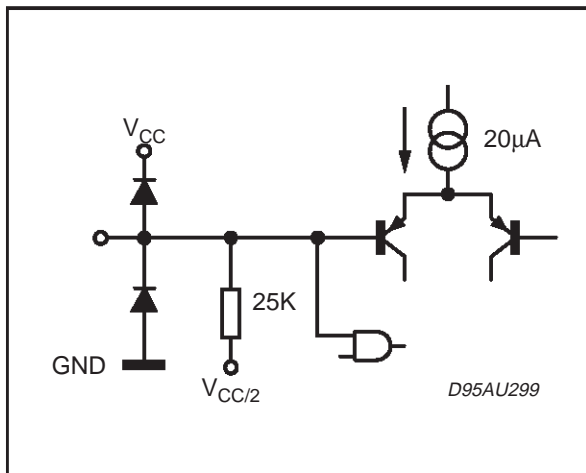

PIN: 62

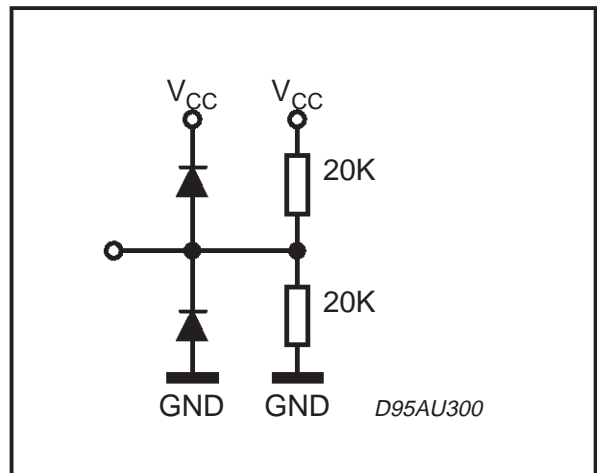

PIN: 63

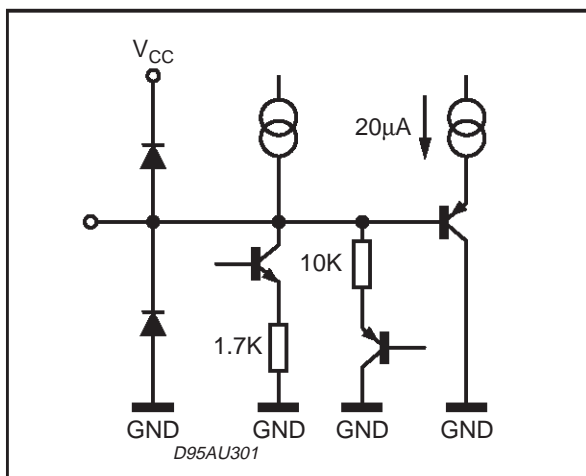

Information furnished is believed to be accurate and reliable. However, STMicroelectronics assumes no responsibility for the consequences of use of such information nor for any infringement of patents or other rights of third parties which may result from its use. No license is granted by implication or otherwise under any patent or patent rights of STMicroelectronics. Specification mentioned in this publication are subject to change without notice. This publication supersedes and replaces all information previously supplied. STMicroelectronics products are not authorized for use as critical components in life support devices or systems without express written approval of STMicroelectronics.

The ST logo is a trademark of STMicroelectronics

© 1998 STMicroelectronics – Printed in Italy – All Rights Reserved

STMicroelectronics GROUP OF COMPANIES

Australia - Brazil - Canada - China - France - Germany - Italy - Japan - Korea - Malaysia - Malta - Morocco - The Netherlands -
Singapore - Spain - Sweden - Switzerland - Taiwan - Thailand - United Kingdom - U.S.A.