

MAXIM

MAX849 Evaluation Kit

General Description

The MAX849 evaluation kit (EV kit) is an assembled and tested PC board that implements a complete, one-cell to three-cell, high-power, low-noise, step-up DC-DC power converter that's ideal for portable phones and other battery-operated equipment. With a 3.3V output voltage, use one or two cells to get a 250mA to 700mA output current. With a 5V output voltage, use three cells or one lithium-ion (Li-Ion) battery to get an 850mA output current.

The board includes clips for a standard AA-size battery, and provides a 10-pin header for user interfacing.

To evaluate the MAX848, order a free sample of the MAX848ESE along with the MAX849 EV kit.

Component List

DESIGNATION	QTY	DESCRIPTION
BAT1	2	Battery clips Keystone 92
C1	1	0.22 μ F ceramic capacitor
C2, C3	2	0.1 μ F ceramic capacitors
C4, C5	2	4.7nF ceramic capacitors
CF1, CF2	2	100 μ F, 6V, 0.1ESR capacitors AVX TPSD107M010R0100
CF3	0	Open
CI1	1	22 μ F, 6V, low-ESR capacitor AVX TPSD226M025R0200
CI2	0	Open
D1	1	0.5A, 20V Schottky diode Motorola MBR0520L
J1	1	10-pin header
JU1	1	2-pin header
JU2	1	3-pin header
L1	1	10 μ H, 1.65A, 4.5mm inductor Sumida CDR74B-100
R1	1	10 Ω , 5% resistor
R2	1	61.9k Ω , 1% resistor
R3	0	Open
R4, R11	2	1k Ω , 5% resistors
R5	1	6.81k Ω , 1% resistor
R6, R7, R9, R10	4	1M Ω , 5% resistors
R8	1	100k Ω , 5% resistor
U1	1	Maxim MAX849ESE

Features

◆ 250mA to 850mA Output Current!

V _{IN} (V)	V _{OUT} (V)	I _{OUT} (mA)
1.2	3.3	250
2.4	3.3	700
2.4	5.0	500
3.6	5.0	850

◆ 90% Efficiency

◆ Proven PC Board Layout

◆ Fully Assembled and Tested

◆ 2-Channel Analog-to-Digital Converter (ADC) with Serial Output for Voltage Monitoring

Ordering Information

PART	TEMP. RANGE	BOARD TYPE
MAX849EVKIT-SO	0°C to +70°C	Surface Mount

Quick Start

This section describes how to operate the MAX849 EV kit, and how to evaluate its performance. **Do not turn on the power supply until all connections are completed.**

- 1) Configure the jumper and resistor settings as desired. For a standard 3.3V output and 90% power-OK threshold, close jumper JU1 (Table 1).
- 2) Insert an AA-size battery cell into the battery clips. Or, connect a 1V to 3V DC power supply to the VIN and GND input pads. Turn on the power supply. Quiescent supply current for the board with no load should be less than 1mA.
- 3) The EV kit board turns on automatically, and VOUT goes to 3.3V.
- 4) To operate in high-power PWM mode at a particular frequency between 200kHz and 400kHz, leave JU2 open and drive the CLK/SEL pin with pulses at the desired frequency. Or, let the MAX849 determine its own PWM frequency by connecting JU2 1-2. To operate in low-power PFM mode, connect JU2 2-3.

Evaluates: MAX848/MAX849

MAX849 Evaluation Kit

Detailed Description

Evaluating the MAX848

To evaluate the MAX848, first replace U1 with a MAX848ESE. Then remove filter capacitor CF2, replace input capacitor C11 with 10 μ F, and replace L1 with a 22 μ H, 800mA inductor. Table 2 lists recommended component changes for MAX848 evaluation.

Reading the Analog-to-Digital Converter (ADC)

The MAX849's internal ADC produces a pulse train on the DOUT pin, at the CLK/SEL switching frequency. Pulses are skipped in proportion to the selected analog input.

One way to read a value from the ADC is to use a microcontroller's (μ C's) pulse accumulator or counter/timer. With the MAX849's DOUT incrementing the counter, clear it and latch its value after 256 CLK/SEL pulses. The counter's value will be proportional to the analog input voltage.

If the MAX849 is operated in free-running PWM mode (JU2 = 1-2), then the μ C must sense the pulse frequency so it can sample DOUT for the correct period of time. Use the LX output to measure the MAX849's internal frequency.

If the MAX849 is operated in synchronized PWM mode (JU2 = open and CLK/SEL driven externally), then the μ C should use the CLK/SEL pulses to time the DOUT sampling period.

The ADC is not active when CLK/SEL is driven low (JU2 = 2-3).

Setting V_{OUT} and POK Thresholds

When V_{OUT} is in regulation, FB = 1.25V, and when V_{OUT} falls to its trip threshold, POKIN drops to 1.25V. Select R3, R5, and R2 by the following method:

$$\begin{aligned} V_{OUT} &= \text{Nominal output voltage} \\ V_{TRIP} &= \text{Desired POK trip threshold} \\ I_{BIAS} &= \text{Desired resistor bias current, at least } 10\mu\text{A} \\ V_{REF} &= 1.25\text{V} \\ R2 &= V_{REF} / I_{BIAS} \\ R5 &= R2 (V_{OUT} - V_{TRIP}) / V_{TRIP} \\ R3 &= (R2 + R5) [(V_{TRIP} / V_{REF}) - 1] \end{aligned}$$

To set V_{OUT} = 5.0V, set R3 to 178k Ω (do not connect or disconnect JU1 or R3 while the power is on).

Table 1. Jumper Function Table

JUMPER	STATE	FUNCTION
JU1	Open	V _{OUT} and POK set by R3, R5, and R2.
	Closed (default)	3.3V, 10% trip threshold
JU2	1-2	Low-noise PWM mode. CLK/SEL pin is tied to V _{OUT} .
	Open	PWM synchronized to user-supplied CLK/SEL signal.
	2-3 (default R9)	Low-power PFM mode. CLK/SEL pin is tied to GND.

Table 2. Recommended Component Changes for MAX848 Evaluation

DESIGNATION	QTY	FUNCTION
CF2	0	Open
C11	1	10 μ F, 6V, low-ESR capacitor AVX TPSD106M035R0300 (10 μ F, 35V, 0.300 Ω max ESR)
L1	1	22 μ H, 800mA inductor Sumida CD54-220 (22 μ H, 1.11A, 0.18 Ω)
U1	1	MAX848ESE

MAX849 Evaluation Kit

Evaluates: MAX848/MAX849

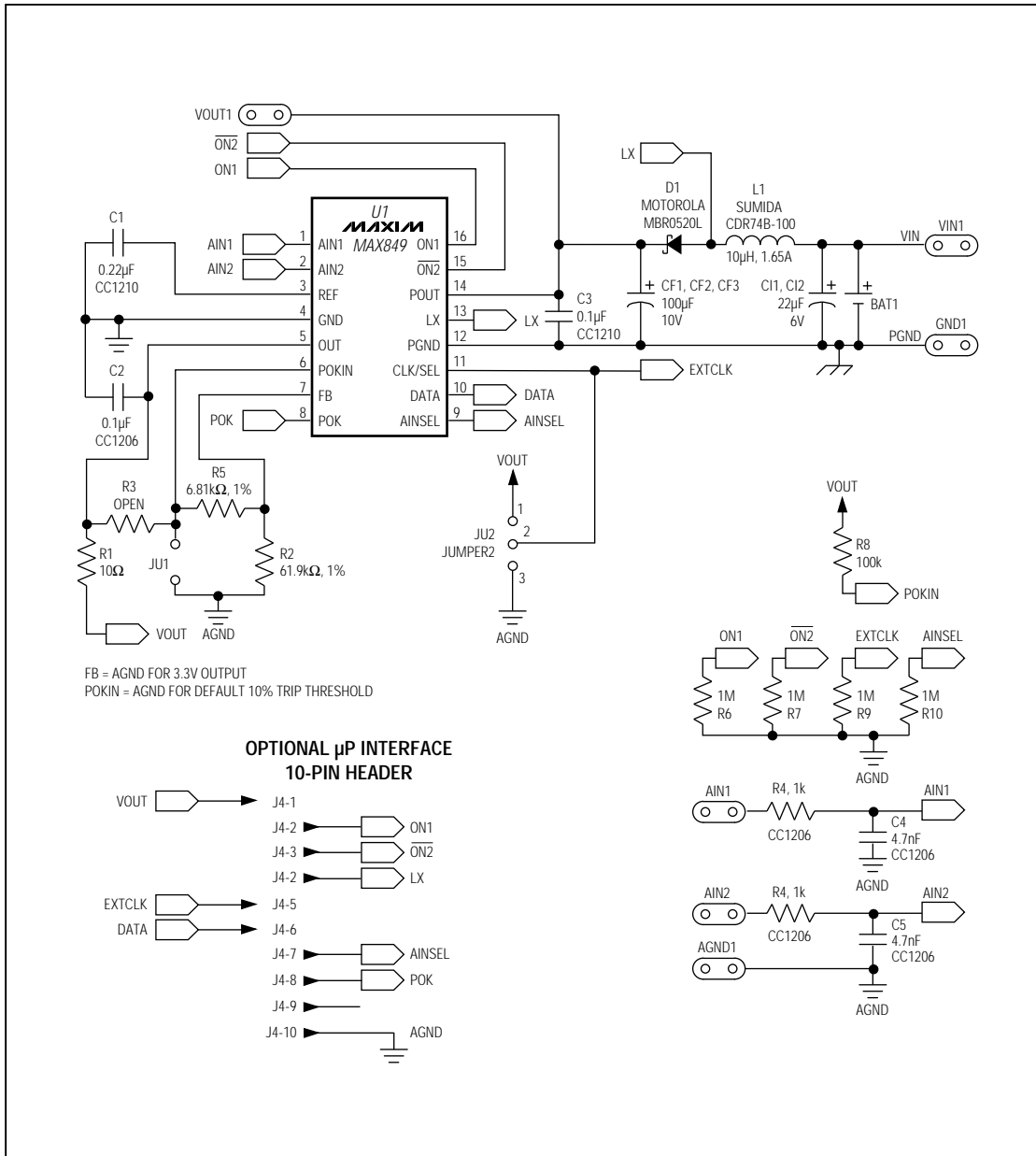

Figure 1. MAX849 EV Kit Schematic

MAX849 Evaluation Kit

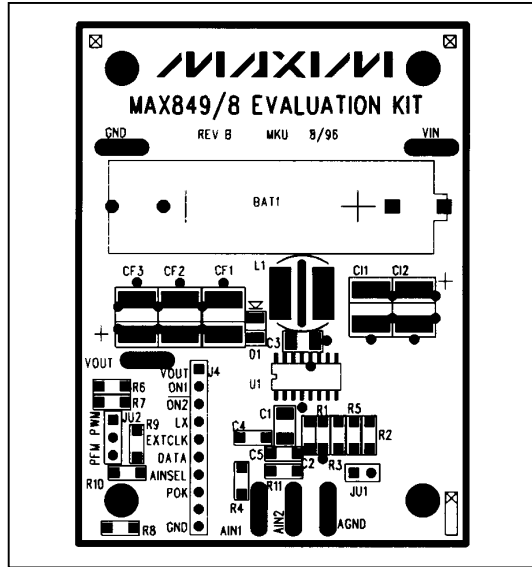

Figure 2. MAX849 EV Kit Component Placement Guide

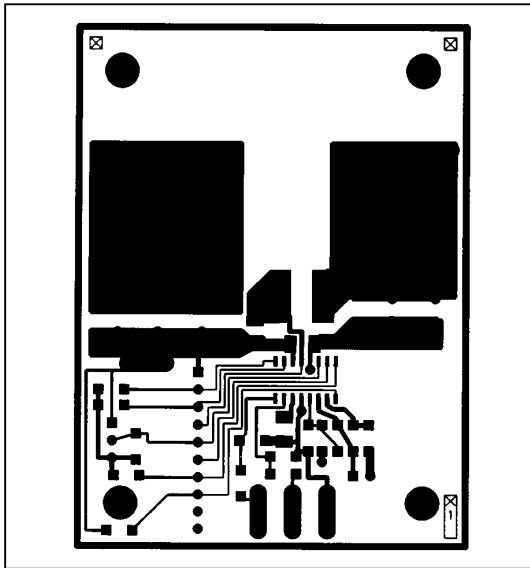

Figure 3. MAX849 EV Kit PC Board Layout—Component Side

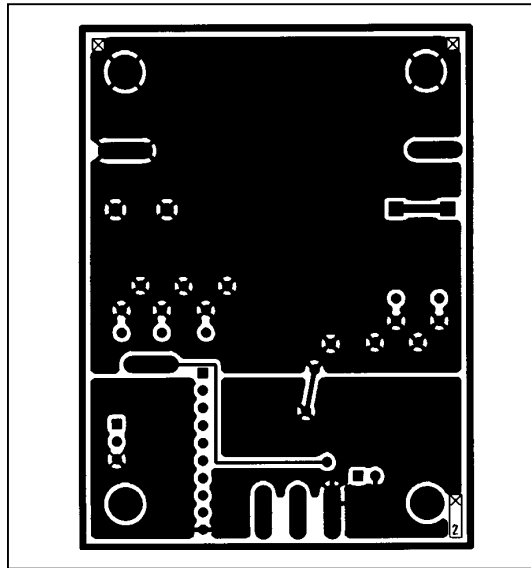

Figure 4. MAX849 EV Kit PC Board Layout—Solder Side

Maxim cannot assume responsibility for use of any circuitry other than circuitry entirely embodied in a Maxim product. No circuit patent licenses are implied. Maxim reserves the right to change the circuitry and specifications without notice at any time.

4 _____ Maxim Integrated Products, 120 San Gabriel Drive, Sunnyvale, CA 94086 (408) 737-7600

© 1996 Maxim Integrated Products

Printed USA

MAXIM is a registered trademark of Maxim Integrated Products.