

DATA COMMUNICATIONS

9-Line ULTRA3 LVD/SE SCSI Terminator

The IMP2119 is a multimode SCSI terminator that conforms to the SCSI Parallel Interconnect-2 (SPI-2) specification developed by the T10 standards committee for low voltage differential (LVD) termination. Multimode compatibility permits the use of legacy devices on the bus without hardware alterations. Automatic mode selection is achieved through voltage detection on the diffsense line.

The IMP2119 delivers the ultimate in SCSI bus performance while saving component cost and board area. Elimination of the external capacitors also mitigates the need for a lengthy capacitor selection process. The individual high bandwidth drivers also maximize channel separation and reduce channel to channel noise and cross talk. The high bandwidth architecture insures ULTRA3 performance.

When the IMP2119 is enabled, the differential sense (DIFFSENSE) pin supplies a voltage between 1.2V and 1.4V. In application, this pin is tied to the DIFFSENSE input of the corresponding LVD transceivers. This action enables the LVD transceiver function. DIFFSENSE is capable of supplying a maximum of 15mA. Tying the DIFFSENSE pin HIGH places the IMP2119 in a high impedance state indicating the presence of an HVD device. Tying the pin LOW places the part in a single-ended mode while also signaling the multimode transceiver to operate in a single-ended mode.

Recognizing the needs of portable and configurable peripherals, the IMP2119 have a TTL compatible sleep/disable mode. During this sleep/disable mode, power dissipation is reduced to a meager 15µA while also placing all outputs in a high impedance state. Also during

Key Features

- ◆ Auto-selectable LVD or single-ended termination
- ◆ 3.0pF maximum disabled output capacitance
- ◆ Fast response, no external capacitors required
- ◆ Compatible with active negation drivers
- ◆ 15µA supply current in disconnect mode
- ◆ Logic command disconnects all termination lines
- ◆ DIFFSENSE line driver
- ◆ Ground driver integrated for single-ended operation
- ◆ Current limit and thermal protection
- ◆ Hot-swap compatible (single-ended)
- ◆ Compatible with SCSI, SPI-2, SPI-3, SPI-4 ULTRA160 and ULTRA320
- ◆ Pin compatible with DS2119

sleep/disable mode, the DIFFSENSE function is disabled and is placed in a high impedance state.

Another key feature of the IMP2119 is the master/slave function. Driving this pin HIGH or floating the pin enables the 1.3V DIFFSENSE reference. Driving the pin LOW disables the on board DIFFSENSE reference and enables use of an external master reference device.

Block Diagram

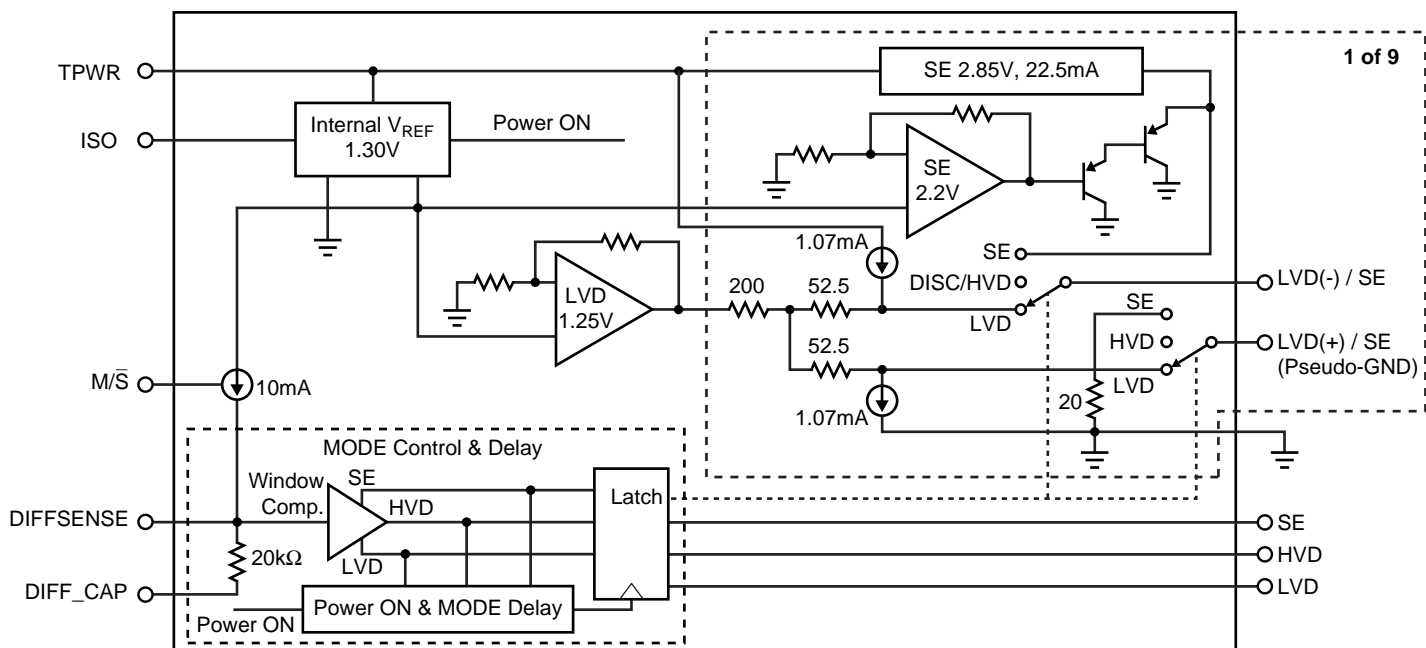

Pin Configuration

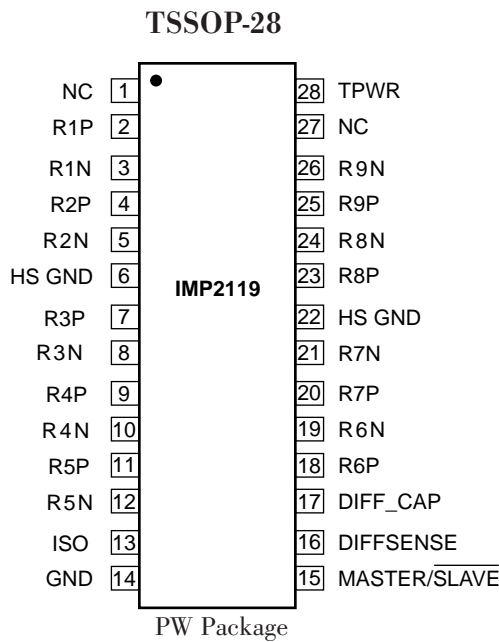

Ordering Information

Part Number	Temperature Range	Package
IMP2119CPW	0°C to 70°C	28-pin Plastic TSSOP

Note: For Tape and Reel, append the letter "T" to part number. (i.e. IMP2119CPW/T)

5241/42_102.eps

Absolute Maximum Ratings¹

TermPwr Voltage +7V
 Operating Junction Temperature
 Plastic (DB, PW Packages) 150°C
 Storage Temperature Range -65°C to 150°C

Lead Temperature (Soldering, 10 sec.) 300°C

Note: 1. Exceeding these ratings could cause damage to the device. All voltages are with respect to Ground. Currents are positive into, negative out of the specified terminal.

Thermal Data

PW Package:
 Thermal Resistance Junction-to-Ambient, θ_{JA} 100°C/W

Junction Temperature Calculation: $T_J = T_A + (P_D \times \theta_{JA})$.
 The θ_{JA} numbers are guidelines for the thermal performance of the device/pc-board system. No ambient airflow is assumed.

Pin Description

Pin Name	Function
R(1,2,3,4,5,6,7,8)N	Negative signal termination lines for LVD mode. Signal termination lines for SE mode.
R(1,2,3,4,5,6,7,8)P	Positive signal termination lines for LVD mode. Pseudo-ground lines for SE mode.
TPWR	Power supply pin for terminator. Connect to SCSI bus TermPwr. Must be decoupled by one 4.7μF low-ESR capacitor for every three terminator devices. It is absolutely necessary to connect this pin to the decoupling capacitor through a very low impedance (big traces on PCB). Keeping distances very short from the decoupling capacitors to the TPWR pin is also critical. The value of the decoupling capacitor is somewhat layout dependant and some applications may benefit from an additional 0.1μF decoupling capacitor at the TPWR pin.
ISO	Enables / disables terminator. See Table 2 for logic levels
GND	Terminator ground pin. Connect to ground
MASTER / SLAVE	Sometimes referred to as M/S pin. Used to select which terminator is the controlling device. MASTER/SLAVE pin HIGH or Open enables the DIFFSENSE output drive. See Table 1.
DIFFSENSE	This is a dual function pin. It drives the SCSI bus DIFFSENS line. It is also the sense pin to detect the SCSI bus mode (LVD, SE or HVD). DIFFSENSE output drive can be disabled with a LOW level on the MASTER/SLAVE pin. See Table 1 and Table 2. Internally connected to DIFF_CAP pin through 20kΩ resistor.
DIFF_CAP	Internally connected to DIFFSENSE pin through 20kΩ resistor. It can be used as a mode sense pin when the device is a non-controlling terminator (MASTER/SLAVE pin is LOW). An RC filter (20kΩ / 0.1μF) is not required on the IMP2119, as it has an internal timer.
N.C.	No Connect. Pins should be left open.

Recommended Operating Conditions²

Parameter	Symbol	Min	Typ	Max	Units	
TermPwr Voltage	LVD	V _{TERM}	3.0		5.25	V
	SE		3.5		5.25	
Signal Line Voltage		0		5.0	V	
Disconnect Input Voltage		0		V _{TERM}	V	
Operating Virtual Junction Temperature Range		0		70	°C	

Note: 2. Range over which the device is functional.

5241/42_103.eps

Electrical Characteristics

Unless otherwise specified, these specifications apply over the operating ambient temperature range of $0^{\circ}\text{C} \leq T_A \leq 70^{\circ}\text{C}$. TermPwr = 4.75V. ISO : IMP2119 = LOW. Low duty cycle pulse testing techniques are used which maintain junction and case temperatures equal to the ambient temperature.

Parameter	Symbol	Condition	Min	Typ	Max	Units
LVD Terminator Section						
TermPwr Supply Current	LVD I _{CC}	All terminator lines = Open		25	30	mA
		ISO > 2.0 V		1	35	μA
Common Mode Voltage	V _{CM}		1.125	1.25	1.375	V
Offset Voltage	V _{FSB}	Open circuit between – and + (see Note 3)	100	112	125	mV
Differential Terminator Impedance	Z _D	V _{OUT} differential = -1V to 1V	100	105	110	Ω
Common Mode Impedance	Z _{CM}	0V to 2.5V	100	200	300	Ω
Output Capacitance	C _O	ISO > 2.0 V		2.5		pF
Output Leakage	I _{LEAK}	ISO > 2.0V V _{LINE} = 0V to 4V, T _A = 25°C			2	μA
		ISO > 2.0 V TPWR = 0V, V _{LINE} = 2.7V		1		
Mode Change Delay	t _{DF}	DIFFSENSE = 1.4V to 0V		115		ms
DIFFSENSE Section						
DIFFSENSE Output Voltage	V _{DIFF}		1.2	1.3	1.4	V
DIFFSENSE Output Source Current	I _{DIFF}	V _{DIFF} = 0V	5.0		15.0	mA
DIFFSENSE Sink Current	I _{SINK (DIFF)}	V _{DIFF} = 2.75V			200	μA
DIFFSENSE Output Leakage	I _{LEAK (DIFF)}	ISO > 2.0V T _A = 25°C			10	μA
Single-Ended Terminator Section						
TermPwr Supply Current	SE I _{CC}	All terminator lines = Open, MASTER/SLAVE = 0V		7	10	mA
		All terminator lines = 0.2V, MASTER/SLAVE = 0V		214	226	
		DISCONNECT > 2.0V		15	35	μA
Terminator Output High Voltage	V _O		2.6	2.85		V
Output Current	I _O	V _{OUT} = 0.2V	21	23	24	mA
Sink Current	I _{SINK}	V _{OUT} = 4V, all lines	45	65		mA
Output Capacitance	C _O	ISO > 2.0V		2.5		pF
Leakage Current	I _{LEAK}	ISO > 2.0V V _{OUT} = 0V to 4V, T _A = 25°C			2	μA
		ISO > 2.0V TPWR = 0V, V _{LINE} = 2.7V, T _A = 25°C		1		
Ground Driver Impedance	Z _G	I = 1mA			100	Ω
Thermal Shutdown				150		°C

Note: 3. Open circuit fallsafe voltage.

Electrical Characteristics

Parameter	Symbol	Condition	Min	Typ	Max	Units
ISO Section						
ISO Thresholds	V_{TH}		0.8		2.0	V
Input Current	I_{IL}	ISO = 0 V			10	μ A
	I_{IH}	ISO = 2.4V		100		nA
MASTER/SLAVE Section						
MASTER/SLAVE Thresholds	$V_{TH (MS)}$		0.8		2.0	V
Input Current	$I_{IL (MS)}$	MASTER/SLAVE = 0V			10	μ A
	$I_{IL (MS)}$	MASTER/SLAVE = 2.4V		100		nA

5241/42_105.a13

Application Information

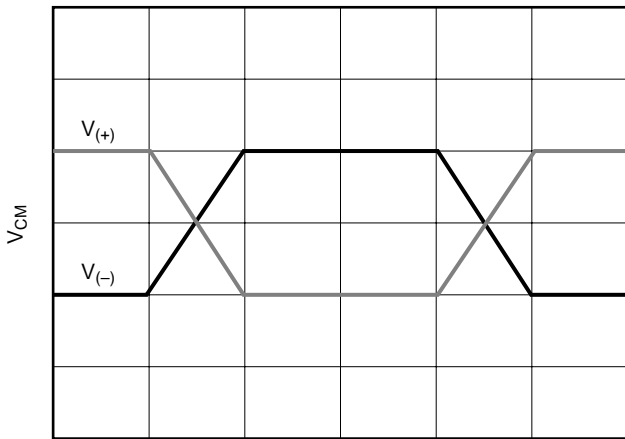

5241/42_04.eps

Figure 1. Bus Voltage

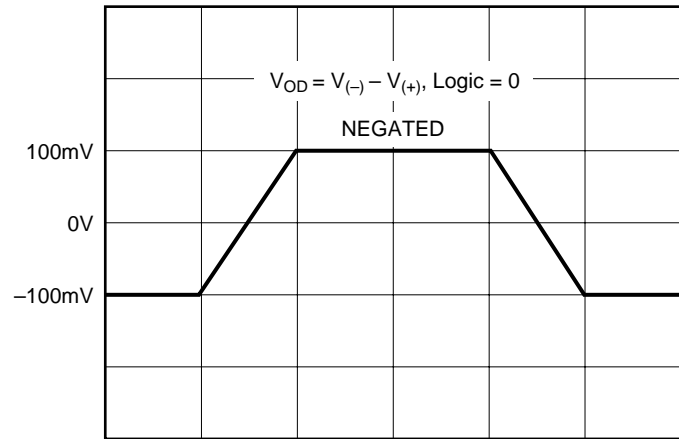

5241/42_05.eps

Figure 2. V_{OD}

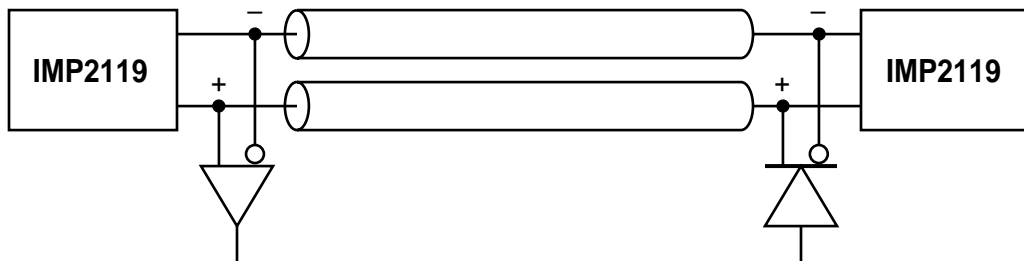

5241/42_06.eps

Figure 3.

Table 1. MASTER/SLAVE Function Table

MASTER/SLAVE	DIFFSENSE Status	Output Current
L*	HiZ	0mA
H	1.3V	15mA Source
Open (Pull-up)	1.3V	15mA Source

5241/42_106.at3

* When in the LOW state, the terminator will detect the DIFFSENSE line state.

Table 2. DIFFSENSE/Power Up/Power Down Function Table

IMP2119 DISCONNECT	DIFFSENSE	Outputs		Current
		Status	Type	
L	$L < 0.5V$	Enable	SE	7mA
L	0.7V to 1.9V	Enable	LVD	21mA
L	$H > 2.4V$	Disable	Hi Z	1mA
H	X	Disable	Hi Z	10 μ A
Open	X	Disable	Hi Z	10 μ A

5241/42_107.eps

Application Information

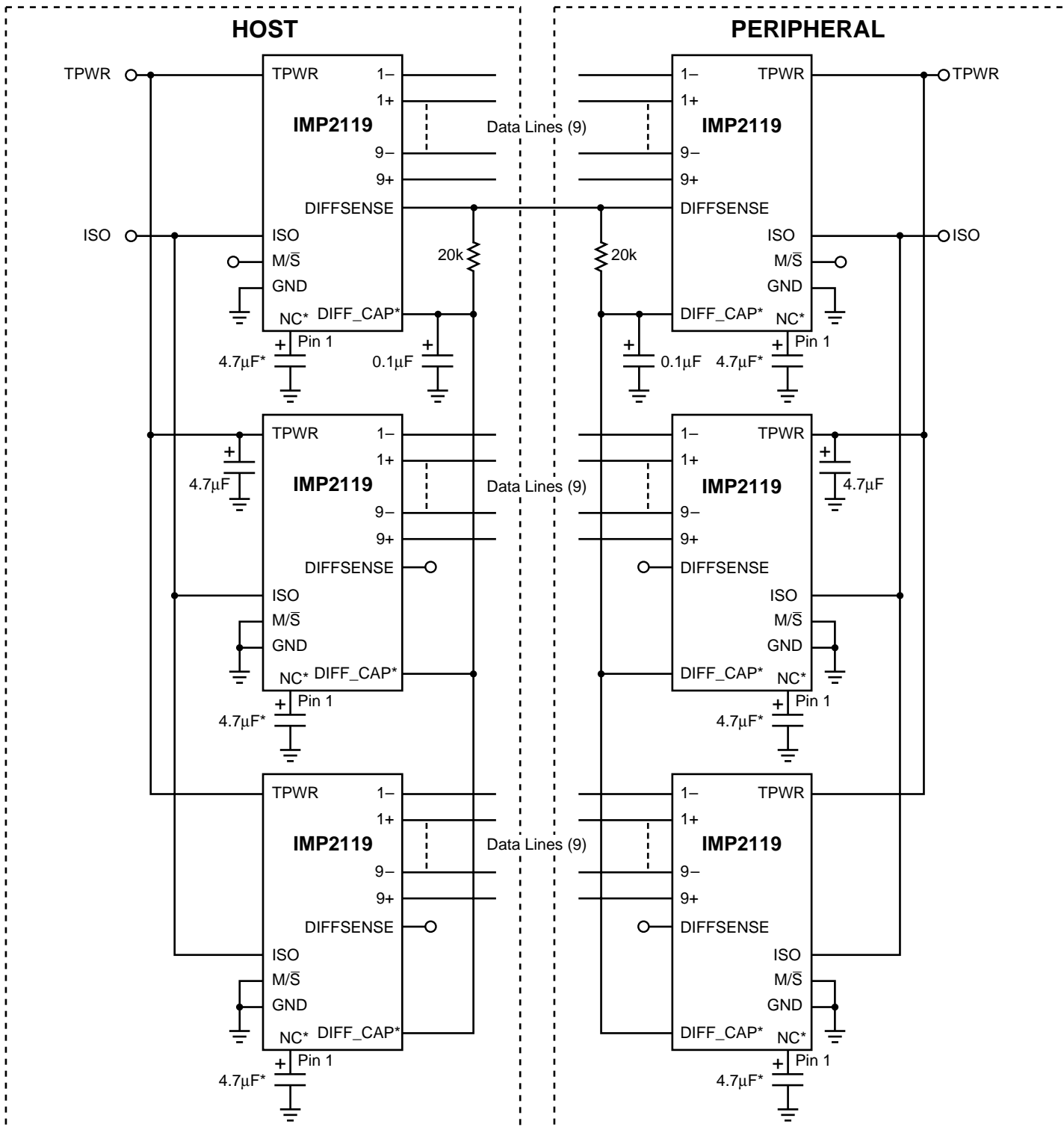

* The capacitor on pin 1 can be placed on the IMP2119CPW. This capacitor is not required with IMP devices.

Figure 5. Suggested IMP2119 Universal Application Schematic

Package Dimensions

PW

Thin Small Shrink Outline (TSSOP) (28-Pin)

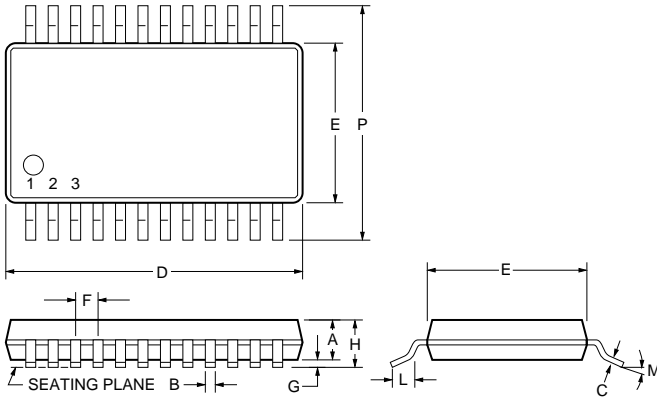

24-Pin (TSSOP).eps

	Inches		Millimeters	
	Min	Max	Min	Max
Thin Small Shrink Outline (TSSOP) (28-Pin)				
A	.032	.041	0.80	1.05
B	0.007	0.012	0.19	0.30
C	0.0035	0.0079	0.09	0.20
D	0.378	0.386	9.60	9.80
E	0.169	0.176	4.30	4.5
F	0.025 BSC		0.65 BSC	
G	0.002	0.005	0.05	0.15
H	–	0.047	–	1.20
L	0.017	0.030	0.45	0.75
M	0°	8°	0°	8°
P	0.246	0.256	6.25	6.50
*LC	–	0.004	–	0.10

* Lead Coplanarity.

5241/42_101.eps



IMP, Inc.
Corporate Headquarters
2830 N. First Street
San Jose, CA 95134-2071
Tel: 408-432-9100
Fax: 408-434-1085
e-mail: info@impinc.com
<http://www.impweb.com>