

T-1³/₄, 2 mm X 5 mm Rectangular Bicolor LED Lamps High Efficiency Red/ High Performance Green

Technical Data

Features:

- Two Color (Red, Green) Operation
- (Other Two LED Color Combinations Available)
- Three Leads with One Common Cathode
- Option of Straight or Spread Lead Configurations
- Diffused, Wide Visibility Lens

Description

The T-1 3/4 HLMP-4000 and 2 mm by 5 mm rectangular HLMP-0800 are three leaded bicolor light sources designed for a variety of applications where dual state illumination is required in the same package. There are two LED chips, high efficiency red (HER), and high performance green (Green), mounted on a central common cathode lead for maximum on-axis viewability. Colors between HER and Green can be generated by independently pulse width modulating the LED chips.

Other Bicolor Combinations

Other bicolor combinations are available:

- HER/yellow
- HER/green
- DH AlGaAs red/green.

Contact your local Hewlett-Packard Components Field Sales representative for details.

Package Dimensions

HLMP-4000

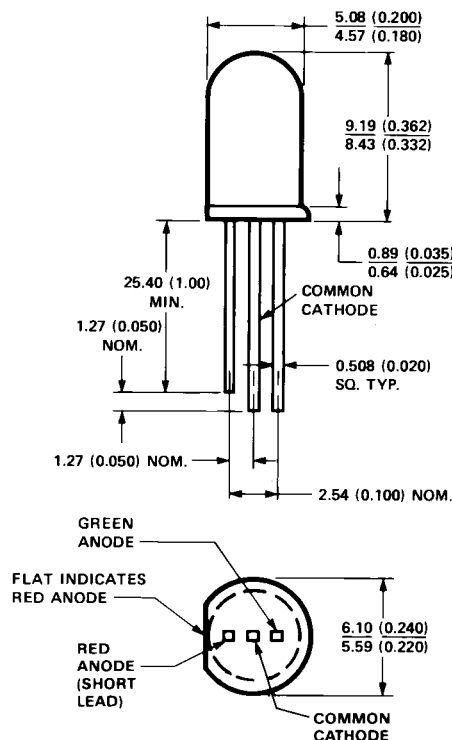

HLMP-4000
HLMP-0800



HLMP-0800

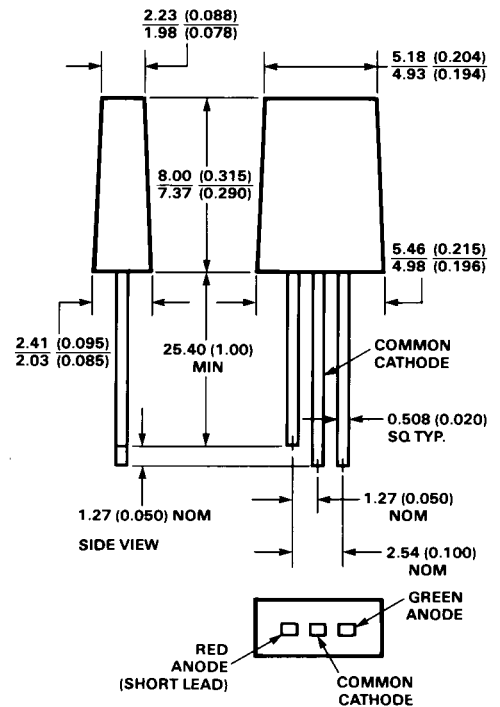

NOTES:

1. ALL DIMENSIONS ARE IN MILLIMETRES (INCHES).
2. AN EPOXY MENISCUS MAY EXTEND ABOUT 1 mm (0.040") DOWN THE LEADS.

Package Dimensions, continued

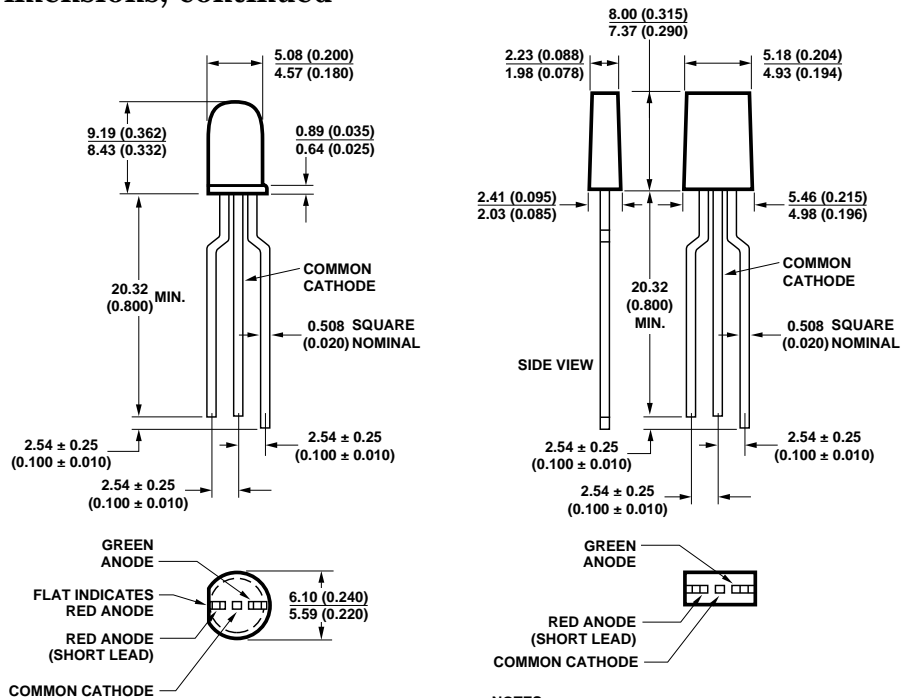

- NOTES:
 1. ALL DIMENSIONS ARE IN MILLIMETERS (INCHES).
 2. AN EPOXY MENISCUS MAY EXTEND ABOUT 1 MM (0.040") DOWN THE LEADS.

Absolute Maximum Ratings at $T_A = 25^\circ\text{C}$

Parameter	High Efficiency Red/Green	Units
Peak Forward Current	90	mA
Average Forward Current ^[1,2] (Total)	25	mA
DC Current ^[2,4] (Total)	30	mA
Power Dissipation ^[3,5] (Total)	135	mW
Operating Temperature Range	-20 to +85	°C
Storage Temperature Range	-55 to +100	
Reverse Voltage ($I_R = 100 \mu\text{A}$)	5	V
Transient Forward Current ^[6] (10 μsec Pulse)	500	mA
Lead Soldering Temperature [1.6 mm (0.063 in.) below seating plane]	260°C for 5 seconds	

Notes:

- See Figure 5 to establish pulsed operating conditions.
- The combined simultaneous current must not exceed the maximum.
- The combined simultaneous power must not exceed the maximum.
- For HER and Green derate linearly from 50°C at 0.5 mA/°C.
- For HER and Green derate linearly from 25°C at 1.8 mW/°C.
- The transient peak current is the maximum non-recurring current that can be applied to the device without damaging the LED die and wirebond. It is not recommended that the device be operated at peak currents beyond the peak forward current listed in the Absolute Maximum Ratings.

Electrical/Optical Characteristics at $T_A = 25^\circ\text{C}$

Sym.	Parameter	Red			Green			Units	Test Conditions
		Min.	Typ.	Max.	Min.	Typ.	Max.		
I_V	Luminous Intensity HLMP-4000	2.1	5		4.2	8		mcd	$I_F = 10\text{ mA}$
	HLMP-0800	2.1	3.5		2.6	4.0			$I_F = 20\text{ mA}$
λ_{PEAK}	Peak Wavelength		635			565		nm	
λ_d	Dominant Wavelength ^[1]		626			569			
τ_s	Speed of Response		90			500		ns	
C	Capacitance		11			18		pF	$V_F = 0, f = 1\text{ MHz}$
V_F	Forward Voltage		1.9	2.4		2.1	2.7	V	$I_F = 10\text{ mA}$
V_R	Reverse Breakdown Voltage	5			5			V	$I_R = 100\text{ }\mu\text{A}$
$R\theta_{\text{J-PIN}}$	Thermal Resistance		260		260			$^\circ\text{C/W}$	Junction to Cathode Lead
$2\theta^{1/2}$	Included Angle Between Half Luminous Intensity Points ^[2]							Deg.	$I_F = 10\text{ mA}$
	HLMP-4000		65			65			
	HLMP-0800		100			100			
η_V	Luminous Efficacy ^[3]		145			595		Lumen/Watt	

Notes:

1. The dominant wavelength, λ_d , is derived from the CIE chromaticity diagram and represents the single wavelength which defines the color of the device.
2. $\theta^{1/2}$ is the off-axis angle at which the luminous intensity is half the axial luminous intensity.
3. Radiant intensity, I_e , in watts steradian, may be found from the equation $I_e = I_V/\eta_V$ where I_V is the luminous intensity in candelas and η_V is the luminous efficacy in lumens/watt.

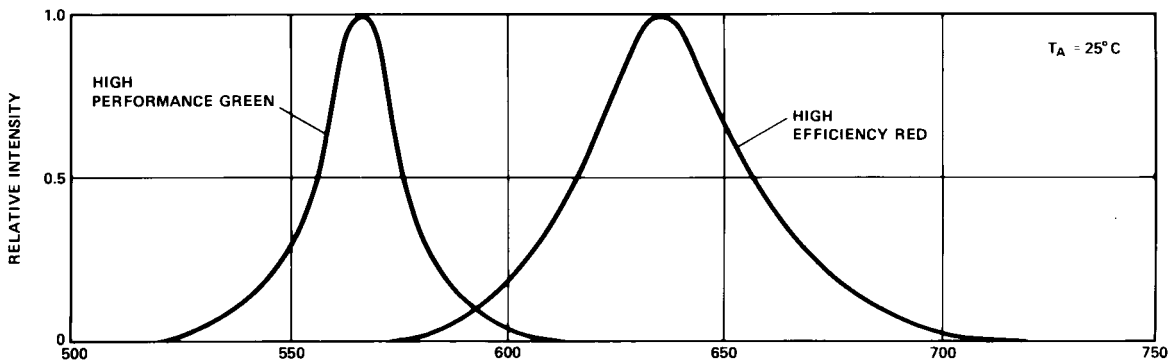

Figure 1. Relative Intensity vs. Wavelength.

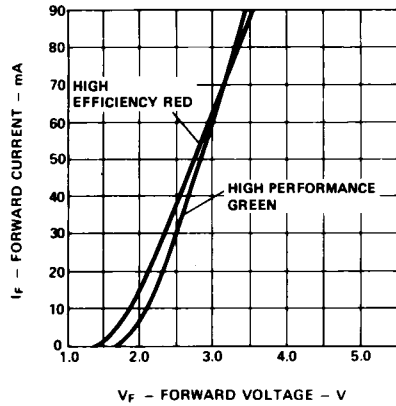

Figure 2. Forward Current vs. Forward Voltage Characteristics.

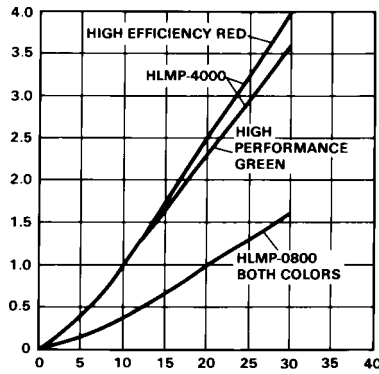

Figure 3. Relative Luminous Intensity vs. DC Forward Current.

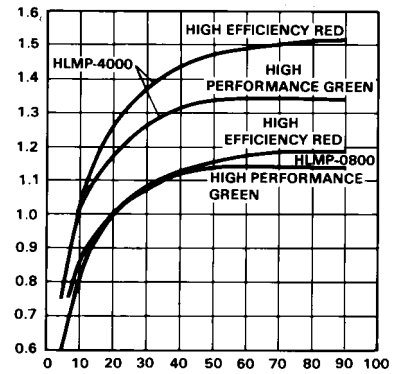

Figure 4. Relative Efficiency (Luminous Intensity per Unit Current) vs. Peak LED Current.

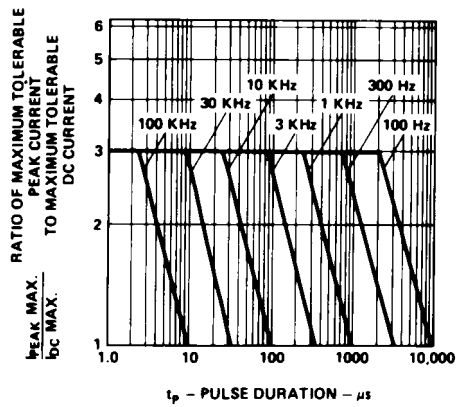

Figure 5. Maximum Tolerable Peak Current vs. Pulse Duration. ($I_{DC\ MAX}$ as per MAX Ratings).

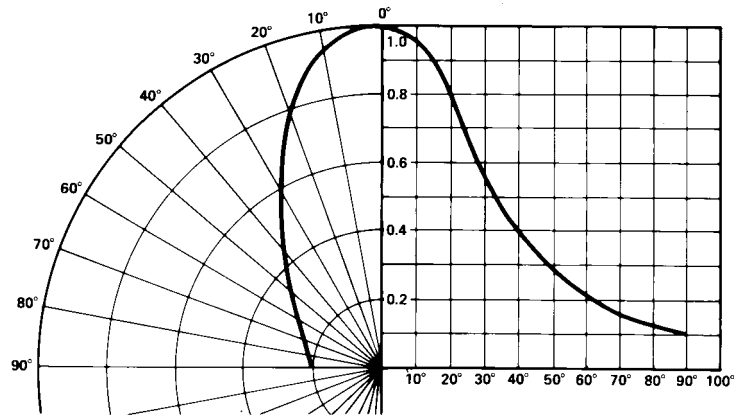

Figure 6. Relative Luminous Intensity vs. Angular Displacement for the HLMP-4000.

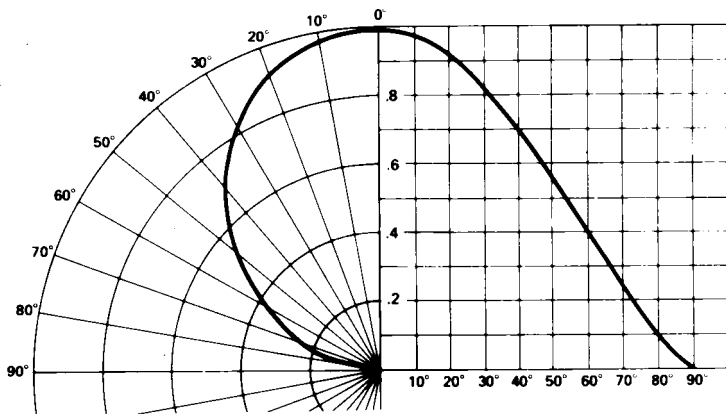

Figure 7. Relative Luminous Intensity vs. Angular Displacement for the HLMP-0800.