



HIGH-SPEED CMOS 8-INPUT BUFFER/LINE DRIVER

IDTQS74FCT2541T/AT/CT

FEATURES:

- CMOS power levels: <7.5mW static
- Undershoot clamp diodes on all outputs
- True TTL input and output compatibility
- Ground bounce controlled outputs
- Reduced output swing of 0 to 3.5V
- Built-in 25Ω series resistor outputs reduce reflection and other system noise
- Std., A and C speed grades with 4.1ns t_{PD} for C
- I_{OL} = 12mA
- Available in SOIC and QSOP packages

DESCRIPTION:

The IDTQS74FCT2541T is an 8-bit buffer/line driver with 3-state outputs and a 25Ω resistor output, ideal for driving transmission lines and reducing system noise. The 2540 series parts can replace the 540 series to reduce noise in an existing design. All inputs have clamp diodes for undershoot noise suppression. All outputs have ground bounce suppression. Outputs will not load an active bus when V_{CC} is removed from the device.

FUNCTIONAL BLOCK DIAGRAM

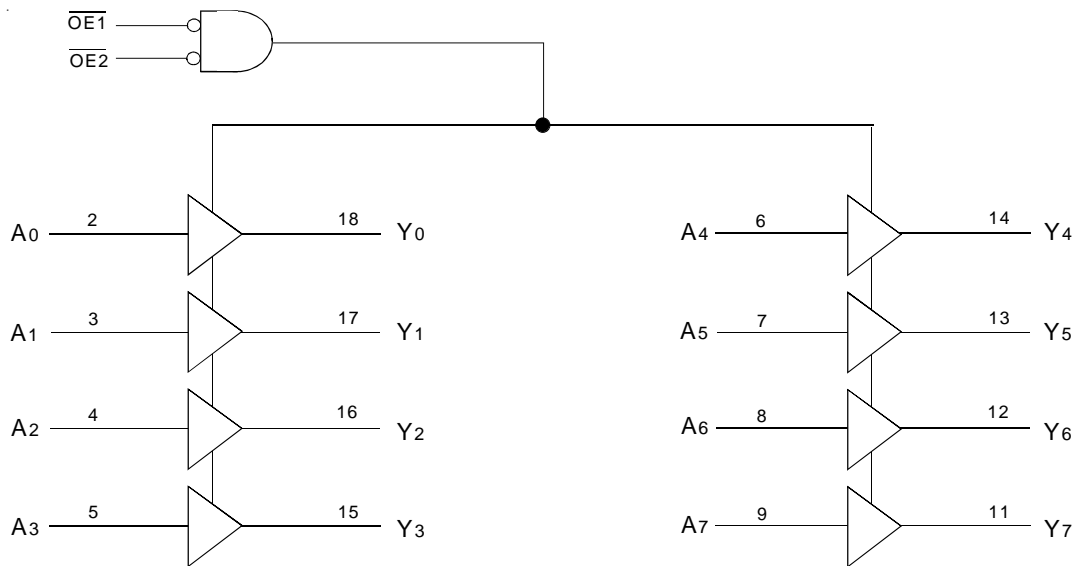

PIN CONFIGURATION

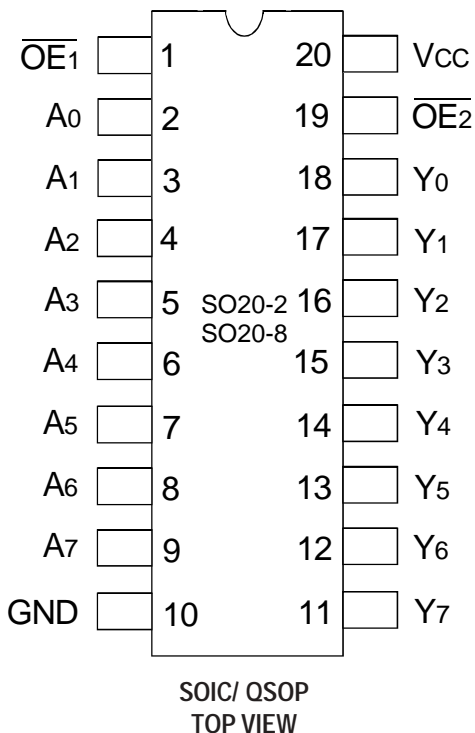

ABSOLUTE MAXIMUM RATINGS⁽¹⁾

Symbol	Description	Max	Unit
VTERM	Terminal Voltage with Respect to GND	-0.5 to +7	V
TSTG	Storage Temperature	-65 to +150	°C
IOUT	DC Output Current Max Sink Current/Pin	120	mA
I _{IK}	Input Diode Current, V _{IN} < 0	-20	mA
I _{OK}	Output Diode Current, V _{OUT} < 0	-50	mA

NOTE:

- Stresses greater than those listed under ABSOLUTE MAXIMUM RATINGS may cause permanent damage to the device. This is a stress rating only and functional operation of the device at these or any other conditions above those indicated in the operational sections of this specification is not implied. Exposure to absolute maximum rating conditions for extended periods may affect reliability.

CAPACITANCE (T_A = +25°C, F = 1.0MHz)

Symbol	Parameter ⁽¹⁾	Conditions	Typ.	Max.	Unit
C _{IN}	Input Capacitance	V _{IN} = 0V	4	—	pF
C _{OUT}	Output Capacitance	V _{OUT} = 0V	8	—	pF

NOTE:

- This parameter is measured at characterization but not tested.

PIN DESCRIPTION

Pin Names	I/O	Description
A _x	I	Data Inputs
Y _x	O	Data Outputs
$\overline{OE1}$, $\overline{OE2}$	I	3-State Output Enable (Active LOW)

FUNCTION TABLE⁽¹⁾

$\overline{OE1}$	$\overline{OE2}$	A Inputs	Y Outputs	Function
H	X	X	Z	Disable Outputs
X	H	X	Z	
L	L	L	L	Enable Outputs
L	L	H	H	

NOTE:

- H = HIGH Voltage Level
L = LOW Voltage Level
X = Don't Care
Z = High-Impedance

DC ELECTRICAL CHARACTERISTICS OVER OPERATING RANGE

Following Conditions Apply Unless Otherwise Specified:

Industrial: $T_A = -40^\circ\text{C}$ to $+85^\circ\text{C}$, $V_{CC} = 5.0\text{V} \pm 5\%$

Symbol	Parameter	Test Conditions		Min.	Typ. ⁽¹⁾	Max.	Unit
V_{IH}	Input HIGH Level	Guaranteed Logic HIGH Level		2	—	—	V
V_{IL}	Input LOW Level	Guaranteed Logic LOW Level		—	—	0.8	V
ΔV_T	Input Hysteresis	$V_{TLH} - V_{THL}$ for all inputs		—	0.2	—	V
I_{IH}	Input HIGH Current	$V_{CC} = \text{Max.}$	$0 \leq V_{IN} \leq V_{CC}$	—	—	± 5	μA
I_{IL}	Input LOW Current						
I_{OZ}	Off-State Output Current (Hi-Z)	$V_{CC} = \text{Max}$	$0 \leq V_{IN} \leq V_{CC}$	—	—	± 5	μA
I_{OR}	Current Drive	$V_{CC} = \text{Max.}, V_{OUT} = 2\text{V}^{(2)}$		50	—	—	mA
V_{IC}	Input Clamp Voltage	$V_{CC} = \text{Min.}, I_{IN} = -18\text{mA}, T_A = 25^\circ\text{C}^{(2)}$		—	-0.7	-1.2	V
V_{OH}	Output HIGH Voltage	$V_{CC} = \text{Min.}$	$I_{OH} = -15\text{mA}$	2.4	—	—	V
V_{OL}	Output LOW Voltage	$V_{CC} = \text{Min.}$	$I_{OL} = 12\text{mA}$	—	—	0.5	V
R_{OUT}	Output Resistance	$V_{CC} = \text{Min.}$	$I_{OL} = 12\text{mA}$	20	28	40	Ω

NOTES:

1. Typical values are at $V_{CC} = 5.0\text{V}$, $T_A = 25^\circ\text{C}$.
2. This parameter is guaranteed but not tested.

POWER SUPPLY CHARACTERISTICS

Following Conditions Apply Unless Otherwise Specified:

Industrial: $T_A = -40^\circ\text{C}$ to $+85^\circ\text{C}$, $V_{CC} = 5.0\text{V} \pm 5\%$

Symbol	Parameter	Test Conditions ⁽¹⁾	Min.	Max.	Unit
I_{CC}	Quiescent Power Supply Current	$V_{CC} = \text{Max.}$ $\text{freq} = 0$ $0\text{V} \leq V_{IN} \leq 0.2\text{V}$ or $V_{CC} - 0.2\text{V} \leq V_{IN} \leq V_{CC}$	—	1.5	mA
ΔI_{CC}	Supply Current per Input TTL Inputs HIGH	$V_{CC} = \text{Max.}$ $V_{IN} = 3.4\text{V}^{(2)}$ $\text{freq} = 0$	—	2	mA
I_{CCD}	Supply Current per Input per MHz	$V_{CC} = \text{Max.}$ Outputs Open and Enabled One Bit Toggling 50% Duty Cycle Other inputs at GND or $V_{CC}^{(3,4)}$	—	0.25	mA/MHz

NOTES:

1. For conditions shown as Min. or Max., use the appropriate values specified under DC Electrical Characteristics.
2. Per TLL driven input ($V_{IN} = 3.4\text{V}$).
3. For flip-flops, I_{CCD} is measured by switching one of the data input pins so that the output changes every clock cycle. This is a measurement of device power consumption only and does not include power to drive load capacitance or tester capacitance.
4. $I_{CC} = I_{QUIESCENT} + I_{INPUTS} + I_{DYNAMIC}$
 $I_{CC} = I_{CC} + \Delta I_{CC} D_H N_T + I_{CCD} (f_{CP}/2 + f_i N_i)$
 I_{CC} = Quiescent Current
 ΔI_{CC} = Power Supply Current for a TTL High Input ($V_{IN} = 3.4\text{V}$)
 D_H = Duty Cycle for TTL Inputs High
 N_T = Number of TTL Inputs at DH
 I_{CCD} = Dynamic Current Caused by an Output Transition Pair (HLH or LHL)
 f_{CP} = Clock Frequency for Register Devices (Zero for Non-Register Devices)
 f_i = Input Frequency
 N_i = Number of Inputs at f_i
 All currents are in milliamps and all frequencies are in megahertz.

SWITCHING CHARACTERISTICS OVER OPERATING RANGE⁽¹⁾

Symbol	Parameter ⁽²⁾	FCT2541T		FCT2541AT		FCT2541CT		Unit
		Min.	Max.	Min.	Max.	Min.	Max.	
t _{PLH} t _{PHL}	Propagation Delay Ax to Yx	2	8	2	4.8	2	4.1	ns
t _{PZH} t _{PZL}	Output Enable \overline{OE} to \overline{Yx}	1.5	10	1.5	6.2	1.5	5.8	ns
t _{PLZ} t _{PHZ}	Disable Time ⁽³⁾	1.5	9.5	1.5	5.6	1.5	5.2	ns

NOTES:

1. C_{LOAD} = 50pF, R_{LOAD} = 500Ω unless otherwise noted.
2. Minimums guaranteed but not tested.
3. This parameter is guaranteed by design but not tested.

TEST CIRCUITS AND WAVEFORMS

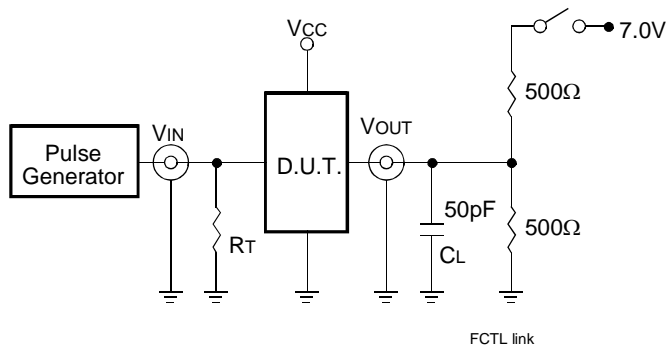

Test Circuits for All Outputs

SWITCH POSITION

Test	Switch
Open Drain Disable Low Enable Low	Closed
All Other Tests	Open

DEFINITIONS:

CL = Load capacitance: includes jig and probe capacitance.
RT = Termination resistance: should be equal to Zout of the Pulse Generator.

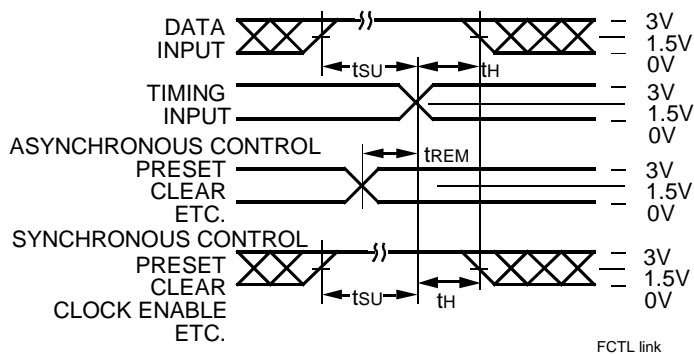

Set-Up, Hold, and Release Times

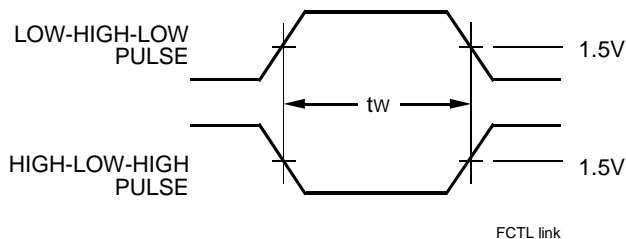

Pulse Width

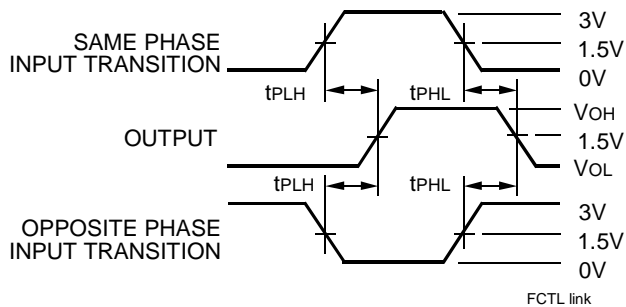

Propagation Delay

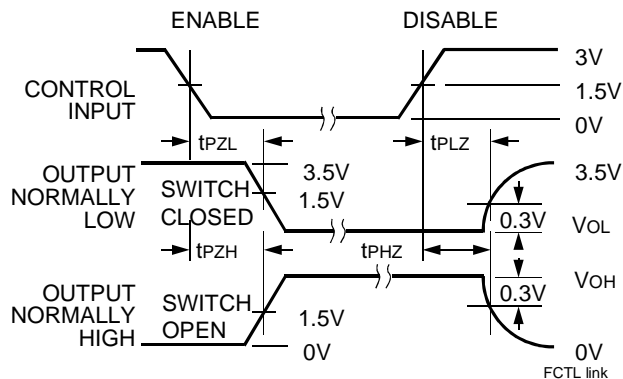

Enable and Disable Times

NOTES:

1. Diagram shown for input Control Enable-LOW and input Control Disable-HIGH.
2. Pulse Generator for All Pulses: Rate \leq 1.0MHz; $t_f \leq$ 2.5ns; $t_r \leq$ 2.5ns.

ORDERING INFORMATION

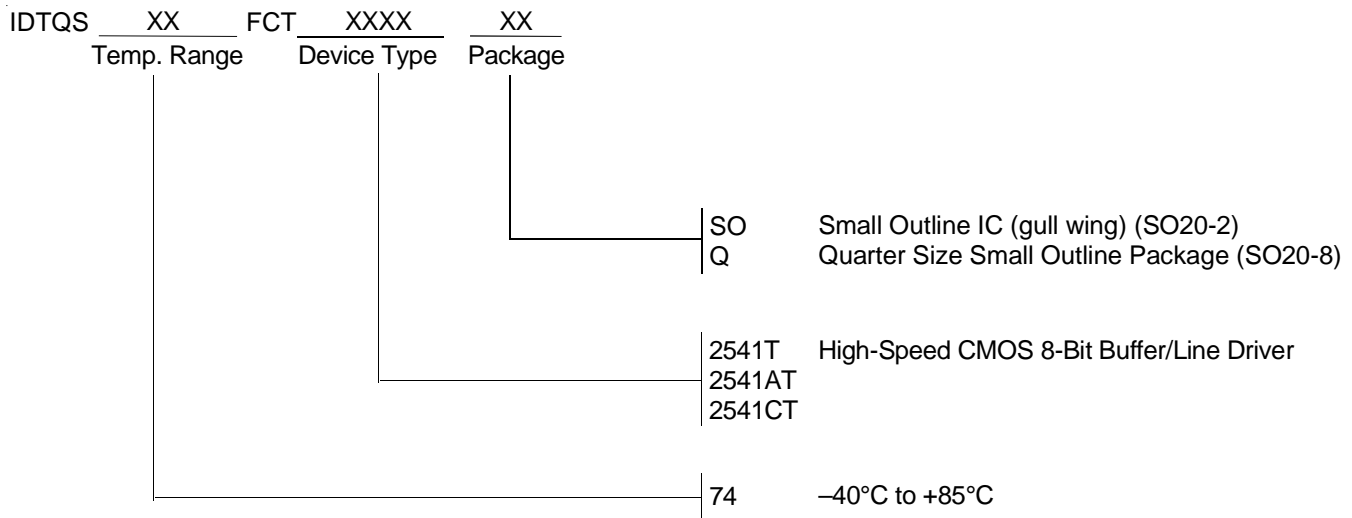

CORPORATE HEADQUARTERS
2975 Stender Way
Santa Clara, CA 95054

for SALES:
800-345-7015 or 408-727-6116
fax: 408-492-8674
www.idt.com

for Tech Support:
logichelp@idt.com
(408) 654-6459