

TOSHIBA POWER TRANSISTOR MODULE SILICON NPN EPITAXIAL TYPE (DARLINGTON POWER TRANSISTOR 4 IN 1)

MP4301

HIGH POWER SWITCHING APPLICATIONS.

HAMMER DRIVE, PULSE MOTOR DRIVE AND INDUCTIVE LOAD SWITCHING.

- Small Package by Full Molding (SIP 12 Pin)
- High Collector Power Dissipation (4 Devices Operation)
: $P_T = 4.4W$ ($T_a = 25^\circ C$)
- High Collector Current : $I_C (DC) = 3A$ (Max.)
- High DC Current Gain : $h_{FE} = 2000$ (Min.) ($V_{CE} = 2V, I_C = 1.5A$)

MAXIMUM RATINGS ($T_a = 25^\circ C$)

CHARACTERISTIC		SYMBOL	RATING	UNIT
Collector-Base Voltage		V_{CBO}	120	V
Collector-Emitter Voltage		V_{CEO}	100	V
Emitter-Base Voltage		V_{EBO}	6	V
Collector Current	DC	I_C	3	A
	Pulse	I_{CP}	6	
Continuous Base Current		I_B	0.5	A
Collector Power Dissipation (1 Device Operation)		P_C	2.2	W
Collector Power Dissipation (4 Devices Operation)		P_T	4.4	W
Junction Temperature		T_j	150	$^\circ C$
Storage Temperature Range		T_{stg}	-55~150	$^\circ C$

INDUSTRIAL APPLICATIONS

Unit in mm

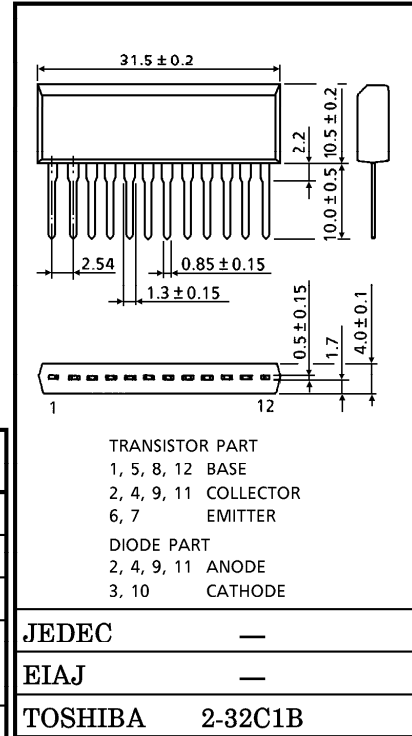

Weight : 3.9g

ARRAY CONFIGURATION

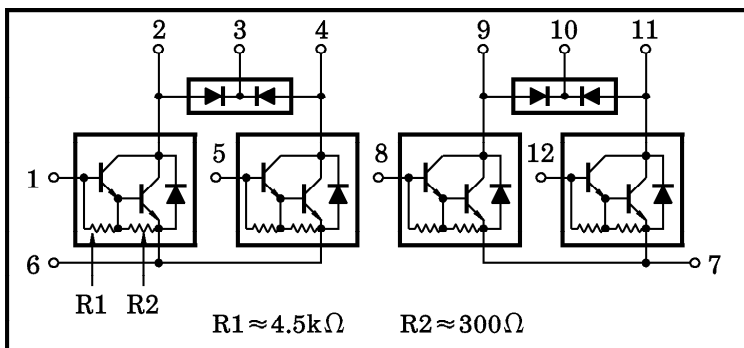

961001EAA2

● TOSHIBA is continually working to improve the quality and the reliability of its products. Nevertheless, semiconductor devices in general can malfunction or fail due to their inherent electrical sensitivity and vulnerability to physical stress. It is the responsibility of the buyer, when utilizing TOSHIBA products, to observe standards of safety, and to avoid situations in which a malfunction or failure of a TOSHIBA product could cause loss of human life, bodily injury or damage to property. In developing your designs, please ensure that TOSHIBA products are used within specified operating ranges as set forth in the most recent products specifications. Also, please keep in mind the precautions and conditions set forth in the TOSHIBA Semiconductor Reliability Handbook.

● The information contained herein is presented only as a guide for the applications of our products. No responsibility is assumed by TOSHIBA CORPORATION for any infringements of intellectual property or other rights of the third parties which may result from its use. No license is granted by implication or otherwise under any intellectual property or other rights of TOSHIBA CORPORATION or others.

● The information contained herein is subject to change without notice.

THERMAL CHARACTERISTICS

CHARACTERISTIC	SYMBOL	MAX.	UNIT
Thermal Resistance of Junction to Ambient (4 Devices Operation, Ta=25°C)	$\Sigma R_{th(j-a)}$	28.4	°C / W
Maximum Lead Temperature for Soldering Purposes (3.2mm from Case for 10s)	T _L	260	°C

ELECTRICAL CHARACTERISTICS (Ta = 25°C)

CHARACTERISTIC		SYMBOL	TEST CONDITION	MIN.	TYP.	MAX.	UNIT
Collector Cut-off Current		I _{CBO}	V _{CB} = 120V, I _E = 0	—	—	10	μA
Collector Cut-off Current		I _{CEO}	V _{CE} = 100V, I _B = 0	—	—	10	μA
Emitter Cut-off Current		I _{EBO}	V _{EB} = 6V, I _C = 0	0.5	—	2.5	mA
Collector-Base Breakdown Voltage		V _{(BR)CBO}	I _C = 1mA, I _E = 0	120	—	—	V
Collector-Emitter Breakdown Voltage		V _{(BR)CEO}	I _C = 10mA, I _B = 0	100	—	—	V
DC Current Gain		h _{FE} (1)	V _{CE} = 2V, I _C = 1.5A	2000	—	15000	
		h _{FE} (2)	V _{CE} = 2V, I _C = 3A	1000	—	—	
Saturation Voltage	Collector-Emitter	V _{CE(sat)}	I _C = 1.5A, I _B = 3mA	—	—	1.5	V
	Base-Emitter	V _{BE(sat)}	I _C = 1.5A, I _B = 3mA	—	—	2.0	
Transition Frequency		f _T	V _{CE} = 2V, I _C = 0.5A	—	60	—	MHz
Collector Output Capacitance		C _{ob}	V _{CB} = 10V, I _E = 0, f = 1MHz	—	30	—	pF
Switching Time	Turn-on Time	t _{on}		—	0.3	—	μs
	Storage Time	t _{stg}		—	2.0	—	
	Fall Time	t _f		I _{B1} = -I _{B2} = 3mA, DUTY CYCLE ≤ 1%	—	0.4	

EMITTER-COLLECTOR DIODE RATINGS AND CHARACTERISTICS (Ta = 25°C)

CHARACTERISTIC	SYMBOL	TEST CONDITION	MIN.	TYP.	MAX.	UNIT
Maximum Forward Current	I_{FM}	—	—	—	3	A
Surge Current	I_{FSM}	t = 1s, 1 shot	—	—	6	A
Forward Voltage	V_F	$I_F = 1A, I_B = 0$	—	1.2	1.8	V
Forward Voltage	t_{rr}	$I_F = 3A, V_{BE} = -3V,$ $dI_F / dt = -50A / \mu s$	—	1.0	—	μs
Reverse Recovery Charge	Q_{rr}		—	5	—	μC

FLYBACK-DIODE RATINGS AND CHARACTERISTICS (Ta = 25°C)

CHARACTERISTIC	SYMBOL	TEST CONDITION	MIN.	TYP.	MAX.	UNIT
Maximum Forward Current	I_{FM}	—	—	—	3	A
Reverse Current	I_R	$V_R = 120V$	—	—	0.4	μA
Reverse Voltage	V_R	$I_R = 100 \mu A$	120	—	—	V
Forward Voltage	V_F	$I_F = 0.5A$	—	—	1.8	V

