

10 Gbit/s Physical Layer Device for POS, ATM and Ethernet

GENERAL DESCRIPTION

- The S/UNI-9953 is a single chip ATM, POS and 10 Gigabit Ethernet User-Network Interface operating at 9953.28 Mbit/s and 10.3 Gbit/s. The S/UNI 9953 is intended for use in OC-192c and high-density OC-48c POS/ATM applications as well as 10 Gigabit Ethernet WAN and LAN PHY port cards.

FEATURES

- Provides WAN Interface Sub-layer (WIS), Physical Coding Sub-layer (PCS), and Media Access Controller (MAC) functionality for OC-192c rate 10 Gigabit Ethernet WAN PHY datastream.
- Provides PCS and MAC layer functionality for 10.3 Gbit/s 10 Gigabit Ethernet LAN PHY datastream.
- Supports framing, scrambling/descrambling and pointer processing for the following:
 - STS-192c (STM-64-64c).

- 4 x STS-48c (4 x STM-16-16c).
- STS-192 (STM-64) channelized down to STS-48c (STM-16c).
- Supports alarm signal insertion/detection, B1/2/3 processing and insertion/termination of SONET Section/Line/Path overhead bytes (or SDH equivalents).
- Provides ATM and POS payload processing for:
 - STS-192c (STM-64-64c)
 - 4 x STS-48c (4 x STM-16-16c).
 - STS-192 (STM-64) channelized down to STS-48c (STM-16c).

INTERFACES

- Provides SATURN® POS-PHY™ Level 4 16-bit LVDS System-side Interface (clocked at 700 MHz nominal).
- Directly connects to optics via 16 bit by 622 MHz OIF SFI-4 (OIF99.102) or 16 bit by 622/645 MHz IEEE P802.3ae XSBI line-side interfaces.

POS/ATM

- Implements the ATM Forum User Network Interface Specification and the ATM physical layer for Broadband ISDN according to CCITT Rec. I.432.
- Implements the Point-to-Point Protocol (PPP) over SONET/SDH specification according to RFC 2615(1619)/1662 of the PPP Working Group of the Internet Engineering Task Force (IETF).

10 GIGABIT ETHERNET

- Implements 10 Gigabit Ethernet WAN and LAN PHY according the IEEE P802.3ae standard currently under development.
- Provides standard IEEE P802.3ae 10 Gigabit Ethernet Media Access Controller (10GMAC) for frame verification.
- Implements IEEE P802.3ae 64B/66B Physical Coding Sub-layer (PCS).

10 GIGABIT ETHERNET MAC

- Verifies frame integrity (FCS and length checks).

BLOCK DIAGRAM

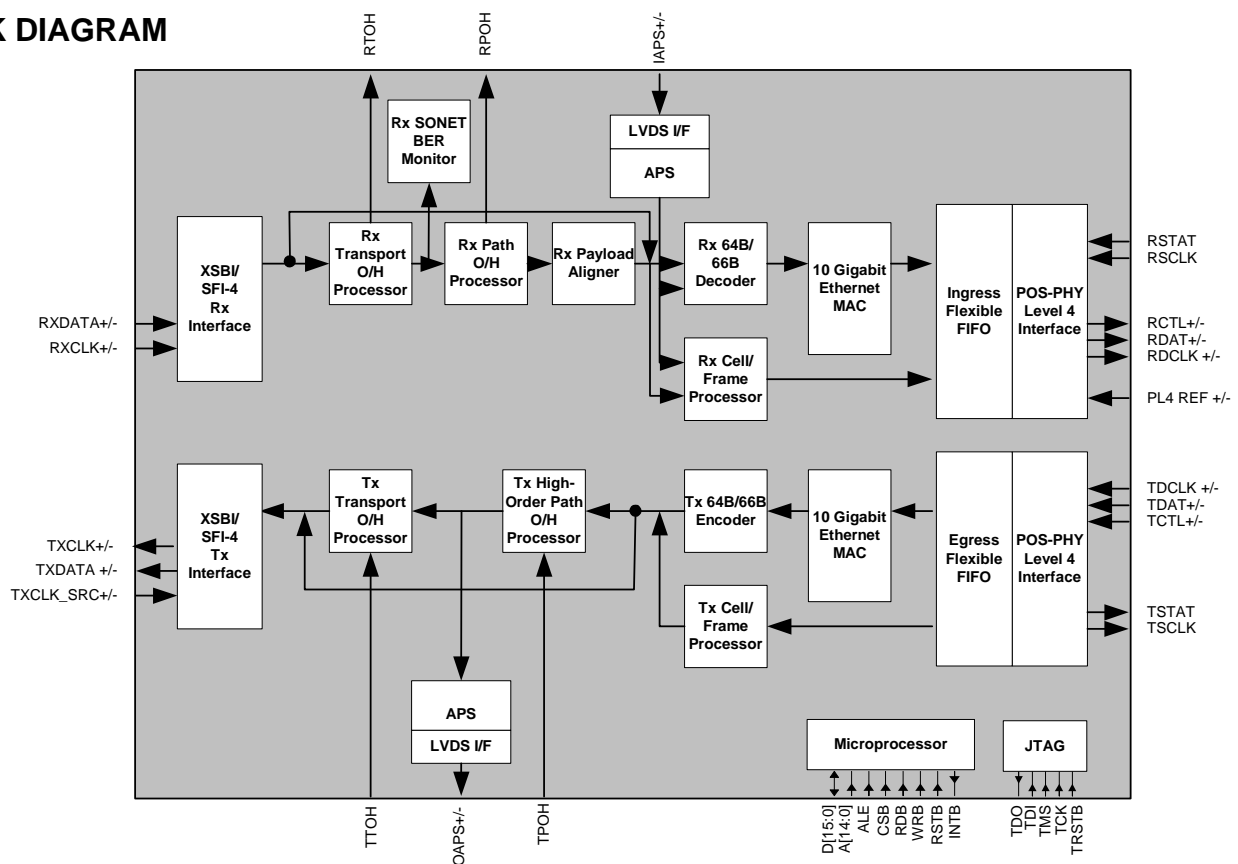

10 Gbit/s Physical Layer Device for POS, ATM and Ethernet

- Provides egress Ethernet frame encapsulation (pads to min. size, add preamble, IFG and CRC generation).
- Supports VLAN tagged frames.
- Provides eight exact-match address filters to filter frames based on SA, DA or VID.
- Provides 64-bin hash based algorithm to filter multicast addresses.
- Minimum frame size of 64 bytes.
- Provides statistics counters to support RMON/SNMP.
- Supports jumbo frames up to 9.6 Kbytes.
- Programmable inter-packet gap (IPG).
- Implements in-band PAUSE flow-control and provides support for out-of-band flow control.
- Upper layer device can flow-control using dedicated pins or host signaling to cause generation of a PAUSE frame.

GENERAL

- Provides internal FIFOs (16 KB ingress, 20 KB egress) to accommodate system latencies.
- Provides line-side and system-side loopbacks for system level diagnostic capability.

- Provides support for automatic protection switching (APS) via two 16-bit LVDS 777.76 MHz ports.
- Provides a generic 16-bit microprocessor bus interface for configuration, control, and status monitoring.
- Standard 5 signal P1149.1 JTAG test port.
- Low power 1.8 V CMOS core logic with 3.3 V CMOS/TTL compatible digital inputs and digital outputs.
- Industrial temperature range (-40 °C to +85 °C).
- 1152 pin FCBGA package.

DEVICE INTERWORKING

- Other PMC-Sierra devices that implement the POS-PHY Level 4 interface include:
 - S/UNI 1x10GE.
 - S/UNI 10xGE.
 - S/UNI 9953-POS.

POS-PHY LEVEL 4 INTERFACE

- Designed to transmit cells, packets or frames between physical and data-link layer devices.
- Supports mixed traffic protocols on a channel by channel basis.

- Requires less pins and draws less power than other 10 Gigabit interface options.
- Compliant with the following standards:
 - Optical Internetworking Forum - System Physical Interface Level 4 Phase II (SPI-4 Phase II).
 - ATM Forum - Frame Based ATM Interface Level 4 (ATMF0161.00).
 - SATURN® POS-PHY™ Level 4, Issue 6, March 2001.

APPLICATIONS

- Edge and Core Routers.
- Multi-Service (Multi-Protocol) Switches.
- Internet POP and Transport POP L2 Ethernet Switches.
- SONET/SDH add/drop multiplexers and optical cross-connects.
- WAN and Edge ATM switches.
- Up-link cards.
- SONET/SDH ATM/POS and 10 Gigabit Ethernet test equipment.
- Emerging DPT, IPT, and GFP applications.

TYPICAL APPLICATION

10 GIGABIT / OC-192 ROUTER PORT CARD APPLICATION

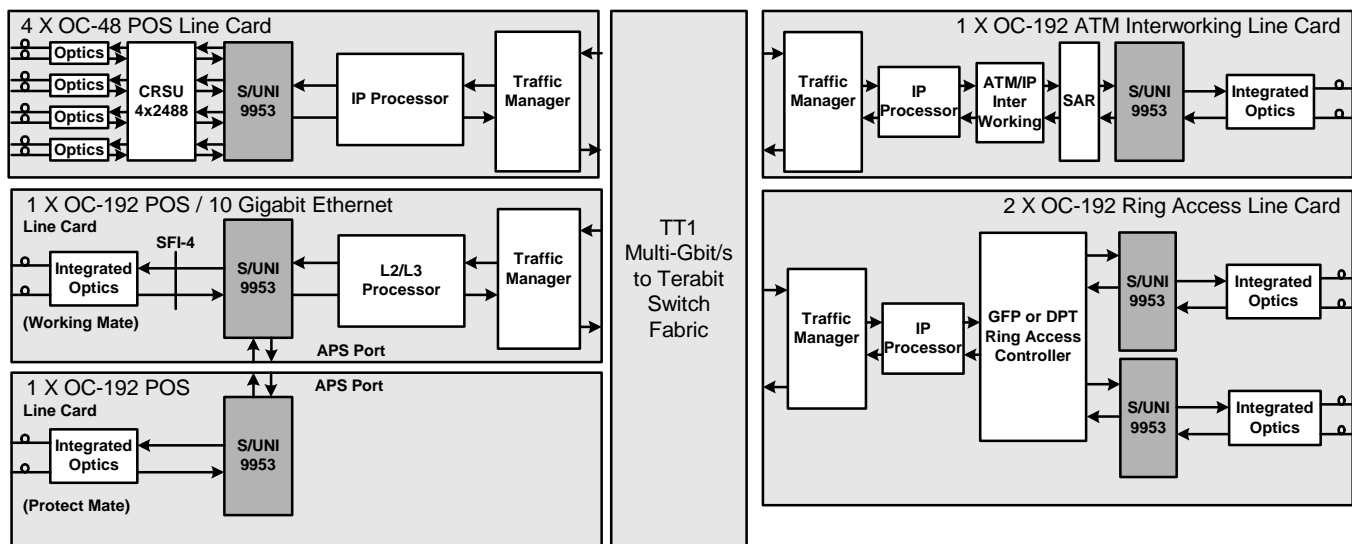

Head Office:
 PMC-Sierra, Inc.
 #105 - 8555 Baxter Place
 Burnaby, B.C. V5A 4V7
 Canada
 Tel: 604.415.6000
 Fax: 604.415.6200

To order documentation,
 send email to:
 document@pmc-sierra.com
 or contact the head office,
 Attn: Document Coordinator

All product documentation is available
 on our web site at:
<http://www.pmc-sierra.com>
 For corporate information,
 send email to:
 info@pmc-sierra.com

PMC-2000181 (A2)
 © Copyright PMC-Sierra,
 Inc. 2001. All rights reserved.
 SATURN and S/UNI are
 registered trademarks and
 POS-PHY and PMC-Sierra
 are trademarks of PMC-
 Sierra, Inc.