

SANYO

No.4578A

2SC4853

NPN Epitaxial Planar Silicon Transistor

Low-Voltage, Low-Current
High-Frequency Amp Applications**Features**

- Low-voltage, low-current operation : $f_T = 5\text{GHz typ.}$
($V_{CE} = 1\text{V}, I_C = 1\text{mA}$) : $|S_{21e}|^2 = 7\text{dB typ (} f = 1\text{GHz)}$
: $NF = 2.6\text{dB typ (} f = 1\text{GHz)}$.

Absolute Maximum Ratings at $T_a = 25^\circ\text{C}$

			unit
Collector to Base Voltage	V_{CB0}	12	V
Collector to Emitter Voltage	V_{CEO}	6	V
Emitter to Base Voltage	V_{EBO}	1.5	V
Collector Current	I_C	15	mA
Collector Dissipation	P_C	80	mW
Junction Temperature	T_j	150	$^\circ\text{C}$
Storage Temperature	T_{stg}	-55 to +150	$^\circ\text{C}$

Electrical Characteristics at $T_a = 25^\circ\text{C}$

			min	typ	max	unit
Collector Cutoff Current	I_{CBO}	$V_{CB} = 5\text{V}, I_E = 0$			1.0	μA
Emitter Cutoff Current	I_{EBO}	$V_{EB} = 1\text{V}, I_C = 0$			10	μA
DC Current Gain	h_{FE}	$V_{CE} = 1\text{V}, I_C = 1\text{mA}$	60*		270*	
Gain-Bandwidth Product	f_T	$V_{CE} = 1\text{V}, I_C = 1\text{mA}$		5		GHz
Output Capacitance	C_{ob}	$V_{CB} = 1\text{V}, f = 1\text{MHz}$		0.6	1.0	pF
Forward Transfer Gain	$ S_{21e} ^2(1)$	$V_{CE} = 1\text{V}, I_C = 1\text{mA}, f = 1\text{GHz}$	4.5	7		dB
	$ S_{21e} ^2(2)$	$V_{CE} = 2\text{V}, I_C = 3\text{mA}, f = 1\text{GHz}$		10.5		dB
Noise Figure	NF(1)	$V_{CE} = 1\text{V}, I_C = 1\text{mA}, f = 1\text{GHz}$		2.6	4.5	dB
	NF(2)	$V_{CE} = 2\text{V}, I_C = 3\text{mA}, f = 1\text{GHz}$		1.9		dB

* : The 2SC4853 is classified by 1mA h_{FE} as follows :

60	3	120	90	4	180	135	5	270
----	---	-----	----	---	-----	-----	---	-----

Marking : CN

 h_{FE} rank : 3, 4, 5**Package Dimensions 2059A**

(unit : mm)

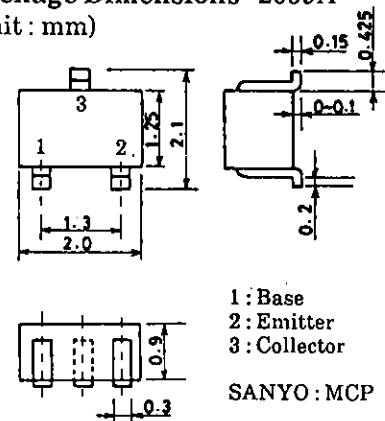
**SANYO Electric Co., Ltd. Semiconductor Business Headquarters**

TOKYO OFFICE Tokyo Bldg., 1-10, 1 Chome, Ueno, Taito-ku, TOKYO, 110 JAPAN

20696YK/41894HO (KOTO) AX-9520 No.4578-1/4

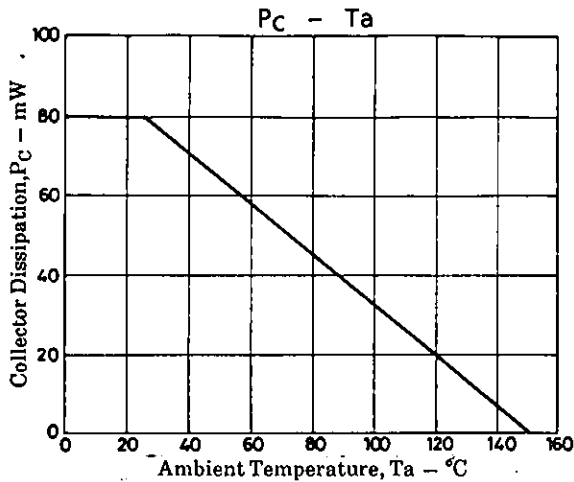
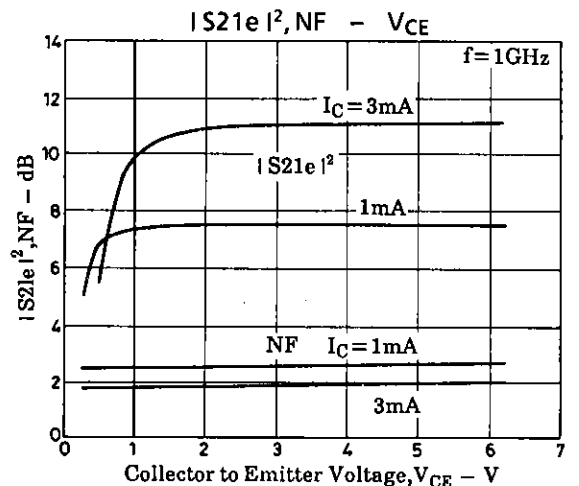
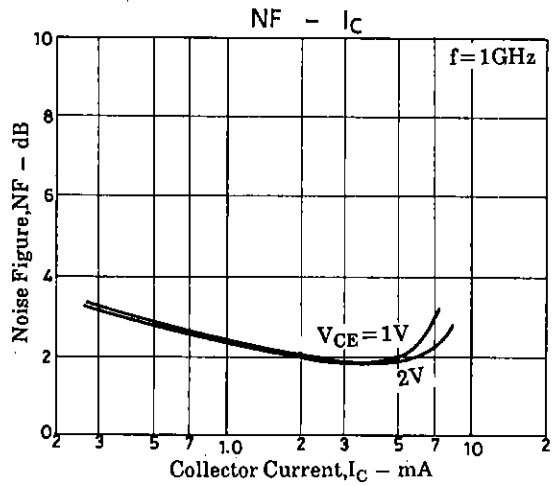
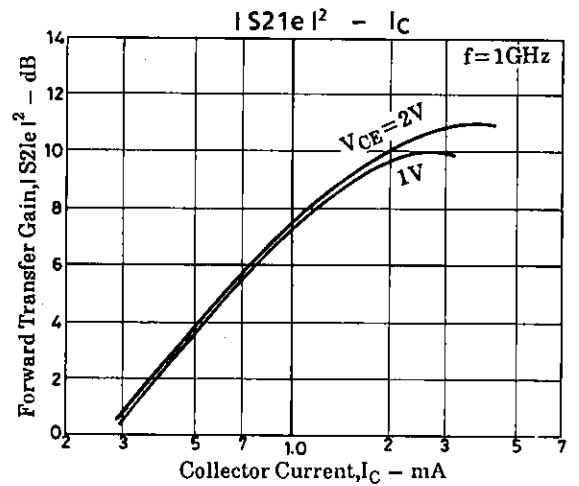
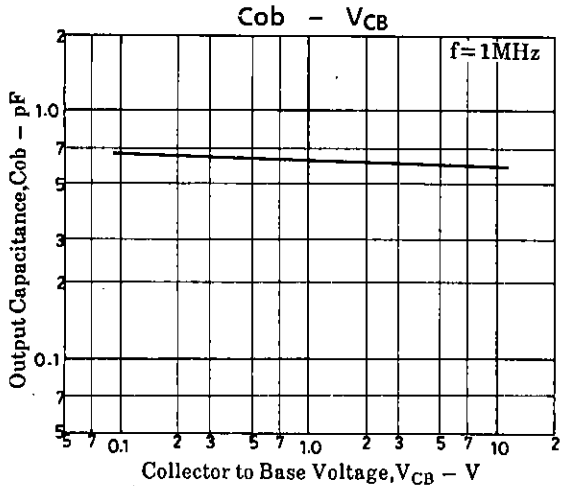
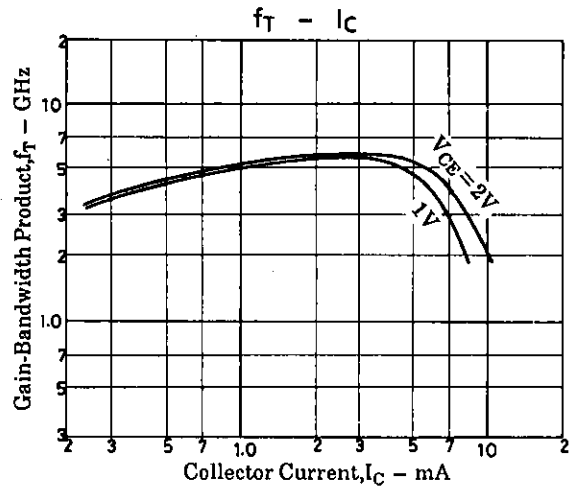
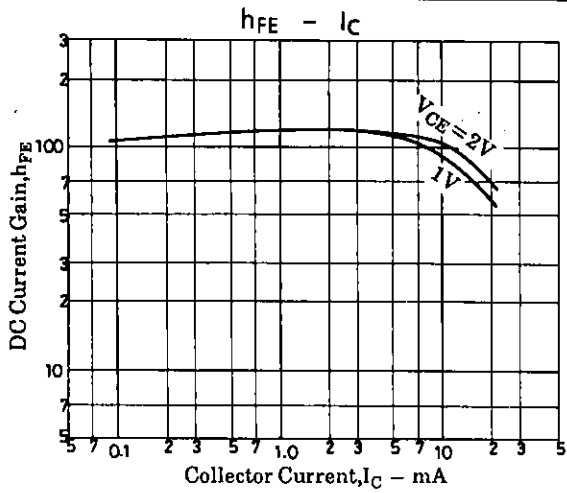

S Parameter

S11e
f = 200~2000MHz (200MHz step)

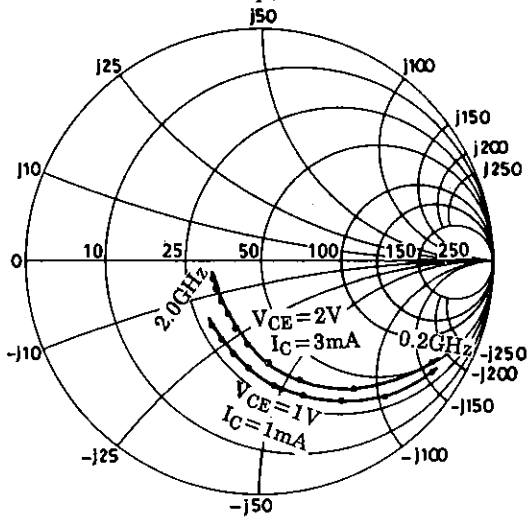

S21e
f = 200~2000MHz (200MHz step)

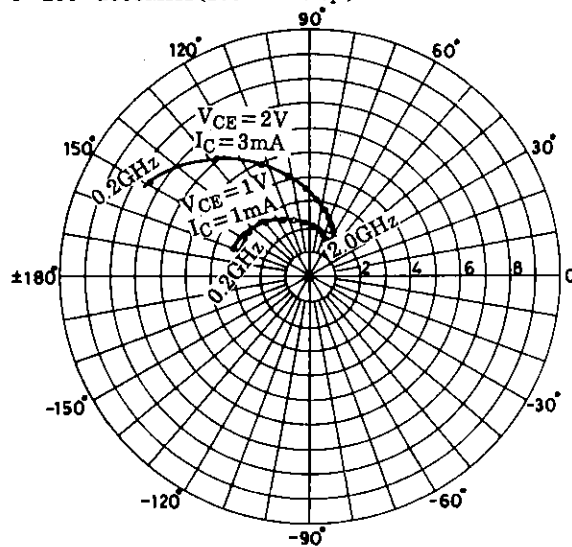

S12e
f = 200~2000MHz (200MHz step)

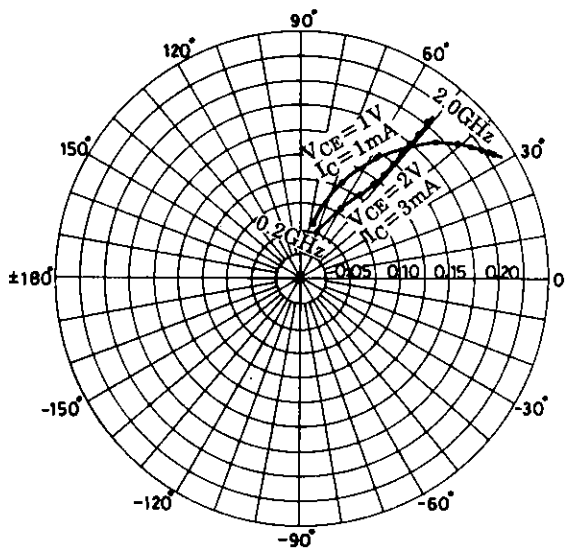

S22e
f = 200~2000MHz (200MHz step)

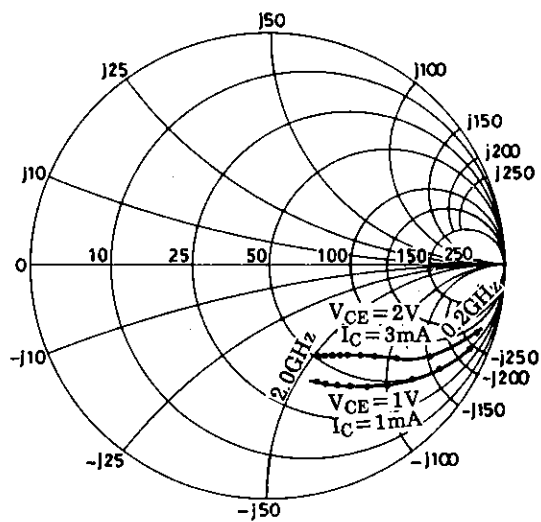

S Parameter (Common emitter)

 $V_{CE}=1V, I_C=1mA, Z_0=50\Omega$

Freq (MHz)	$ S_{11} $	$\angle S_{11}$	$ S_{21} $	$\angle S_{21}$	$ S_{12} $	$\angle S_{12}$	$ S_{22} $	$\angle S_{22}$
200	0.940	-17.9	3.228	159.6	0.058	77.1	0.972	-12.2
400	0.863	-33.7	2.983	143.7	0.107	66.6	0.914	-22.7
600	0.778	-48.0	2.732	129.9	0.145	58.1	0.844	-31.7
800	0.698	-60.5	2.469	117.7	0.173	50.9	0.773	-39.6
1000	0.608	-73.5	2.320	106.2	0.195	45.4	0.717	-46.0
1200	0.546	-84.7	2.106	96.3	0.210	40.9	0.668	-51.7
1400	0.470	-96.2	1.977	87.1	0.129	37.6	0.624	-56.5
1600	0.418	-106.4	1.826	78.8	0.224	35.3	0.590	-60.6
1800	0.388	-117.3	1.700	72.2	0.230	33.8	0.562	-64.3
2000	0.354	-127.0	1.615	65.9	0.234	32.9	0.546	-67.5

 $V_{CE}=2V, I_C=3mA, Z_0=50\Omega$

Freq (MHz)	$ S_{11} $	$\angle S_{11}$	$ S_{21} $	$\angle S_{21}$	$ S_{12} $	$\angle S_{12}$	$ S_{22} $	$\angle S_{22}$
200	0.839	-30.6	7.428	149.3	0.050	71.4	0.916	-18.3
400	0.672	-53.7	6.016	128.5	0.083	60.6	0.778	-30.2
600	0.536	-71.7	4.908	113.6	0.105	55.1	0.672	-37.1
800	0.431	-85.7	4.073	101.9	0.121	52.5	0.597	-41.9
1000	0.360	-99.0	3.494	92.7	0.135	51.4	0.548	-45.7
1200	0.310	-111.4	3.033	84.4	0.150	50.9	0.514	-49.2
1400	0.265	-122.6	2.694	77.4	0.162	50.9	0.492	-52.3
1600	0.242	-134.7	2.422	70.9	0.175	51.0	0.475	-55.6
1800	0.228	-148.0	2.205	65.9	0.189	51.1	0.461	-59.0
2000	0.217	-157.2	2.061	60.8	0.205	51.0	0.456	-61.8

- No products described or contained herein are intended for use in surgical implants, life-support systems, aerospace equipment, nuclear power control systems, vehicles, disaster/crime-prevention equipment and the like, the failure of which may directly or indirectly cause injury, death or property loss.
- Anyone purchasing any products described or contained herein for an above-mentioned use shall:
 - ① Accept full responsibility and indemnify and defend SANYO ELECTRIC CO., LTD., its affiliates, subsidiaries and distributors and all their officers and employees, jointly and severally, against any and all claims and litigation and all damages, cost and expenses associated with such use;
 - ② Not impose any responsibility for any fault or negligence which may be cited in any such claim or litigation on SANYO ELECTRIC CO., LTD., its affiliates, subsidiaries and distributors or any of their officers and employees jointly or severally.
- Information (including circuit diagrams and circuit parameters) herein is for example only; it is not guaranteed for volume production. SANYO believes information herein is accurate and reliable, but no guarantees are made or implied regarding its use or any infringements of intellectual property rights or other rights of third parties.

This catalog provides information as of February, 1996. Specifications and information herein are subject to change without notice.