

March 11, 1998

TEL:805-498-2111 FAX:805-498-3804 WEB:http://www.semtech.com

DESCRIPTION

The SC1150 voltage mode controller contains most of the circuitry necessary to implement a DC/DC converter for powering the Intel Pentium® Pro microprocessor, both in single and multiple processor configurations.

The SC1150 features an integrated D/A converter, pulse by pulse current limiting, integrated power good signaling, logic compatible shutdown and on-board over voltage protection (OVP).

The SC1150 operates at a fixed frequency of 200kHz, providing an optimum compromise between size, efficiency and cost in the intended application areas.

The integrated D/A converter provides programmability of output voltage from 2.0V to 3.5V in 100mV increments with no external components. Both the range and the increment value may be changed by adding external components.

The SC1150 provides an OVP output which can be used to trigger a crowbar circuit for true over voltage protection.

BLOCK DIAGRAM

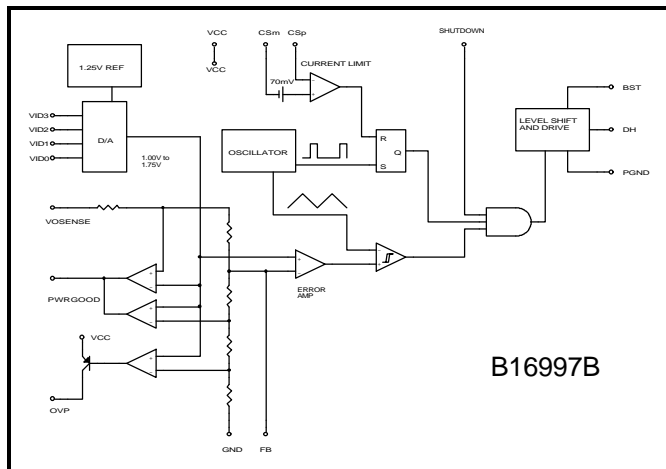

PIN CONFIGURATION

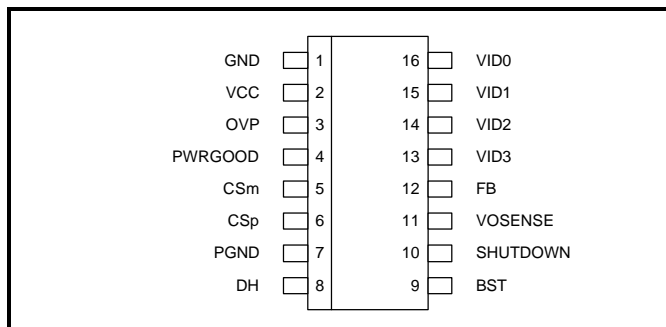

FEATURES

- 85% efficiency
- 4 bit DAC for output programmability
- On chip power good and OVP functions
- Meets Intel Pentium® Pro VRM8.0 specifications

APPLICATIONS

- Pentium® Pro Processor supplies
- Pentium® Pro Processor VRM modules
- 2.0V to 3.5V microprocessor supplies
- Programmable power supplies

ORDERING INFORMATION

DEVICE ⁽¹⁾	PACKAGE	TEMP RANGE (T _J)
SC1150CS	SO-16	0 - 125°C

Note:

(1) Add suffix 'TR' for tape and reel.

ABSOLUTE MAXIMUM RATINGS

Parameter	Symbol	Maximum	Units
V _{CC} to GND	V _{IN}	-0.3 to 7	V
PGND to GND		± 1	V
BST to GND		-0.3 to 15	V
Operating Temperature Range	T _A	0 to 70	°C
Storage Temperature Range	T _{STG}	-65 to +150	°C
Lead Temperature (Soldering) 10 sec	T _{LEAD}	300	°C

March 11, 1998

ELECTRICAL CHARACTERISTICS

 Unless specified: $V_{CC} = 4.75V$ to $5.25V$; $GND = PGND = 0V$; $V_{OSENSE} = V_O$; $0mV < (CSp-CSm) < 60mV$; $T_A = 25^\circ C$

PARAMETER	CONDITIONS	VID 3210	MIN	TYP	MAX	UNITS
Output Voltage ⁽²⁾	$I_O = 2A$ in Application circuit 16935E	1111	1.980	2.000	2.020	V
		1110	2.079	2.100	2.121	
		1101	2.178	2.200	2.222	
		1100	2.277	2.300	2.323	
		1011	2.376	2.400	2.424	
		1010	2.475	2.500	2.525	
		1001	2.574	2.600	2.626	
		1000	2.673	2.700	2.727	
		0111	2.772	2.800	2.828	
		0110	2.871	2.900	2.929	
		0101	2.970	3.000	3.030	
		0100	3.069	3.100	3.131	
		0011	3.168	3.200	3.232	
		0010	3.267	3.300	3.333	
		0001	3.366	3.400	3.434	
0000	3.465	3.500	3.535			
Load Regulation	$I_O = 0.3A$ to $13A^{(1)}$	xxxx		1		%
Line Regulation		xxxx		0.5		%
UV Lockout		xxxx			4.2	V
Current Limit Voltage		xxxx	60	70	80	mV
Oscillator Frequency		xxxx	180	200	220	kHz
Oscillator Max Duty Cycle		xxxx	90	95		%
DH Sink/Source Current	BST - DH = 4.5V, DH - PGND = 2V	xxxx	1			A
Output Voltage Tempco		xxxx		65		ppm/ $^\circ C$

NOTES:

- (1) Low output currents, below the continuous conduction threshold will cause an increase in output voltage beyond the load regulation limit. For Application circuit 16935E see the regulation curve on sheet 5.
- (2) All VID codes not specifically listed here are invalid and cause shutdown exactly as if the shutdown pin had been asserted. xxxx refers to any valid VID code.

March 11, 1998

PIN DESCRIPTION

Pin #	Pin Name	Pin Function
1	GND	Small Signal Analog and Digital Ground
2	V _{CC}	Chip Supply Voltage
3	OVP ⁽¹⁾	High Signal out if V _O >setpoint + 20%
4	PWRGOOD ⁽¹⁾	Open collector logic output, high if V _O within 10% of setpoint
5	CS _m	Current Sense Input (negative)
6	CS _p	Current Sense Input (positive)
7	PGND	Power Ground
8	DH	High side Driver Output
9	BST	V _{CC} for high side Driver
10	SHUTDOWN ⁽¹⁾	Logic low shuts down the converter
11	VOSENSE	Top end of internal feedback chain
12	FB	Voltage Feedback Input
13	VID3 ⁽¹⁾	Programming Input (MSB)
14	VID2 ⁽¹⁾	Programming Input
15	VID1 ⁽¹⁾	Programming Input
16	VID0 ⁽¹⁾	Programming Input (LSB)

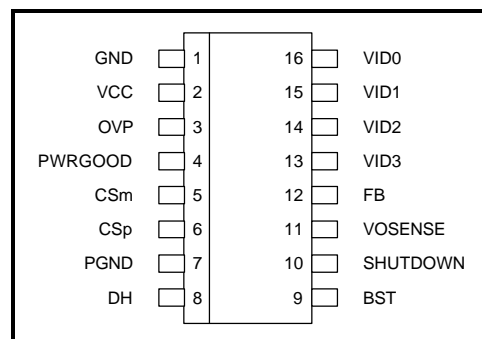
NOTE:

(1) All logic level inputs and outputs are open collector TTL compatible

March 11, 1998

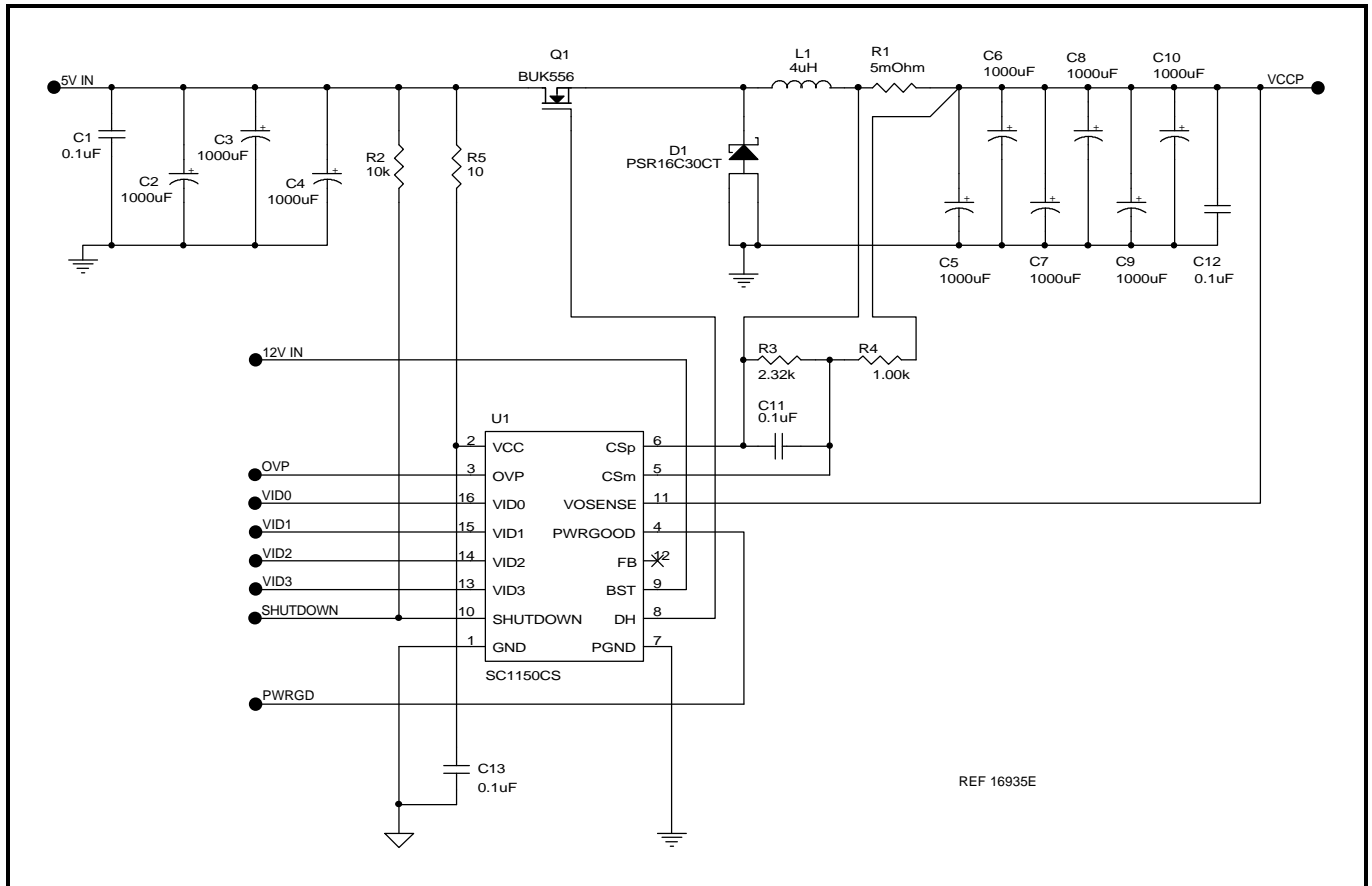
APPLICATION CIRCUIT

MATERIALS LIST

Quantity	Reference	Part/Description	Vendor	Notes
4	C1,C11-C13	0.1 μ F Ceramic	Various	
9	C2-C10	1000 μ F/6.3V	SANYO	MV-GX or equiv. Low ESR
1	D1	PSR16C30CT	PHOTRON	
1	L1	4 μ H		8 Turns 16AWG on MICROMETALS T50-52D core
1	Q1	BUK556	PHILIPS	Logic level FET, $\leq 22\text{m}\Omega$, 30V
1	R1	5m Ω	IRC	OAR-1 Series
1	R2	10k Ω , 5%, 1/8W	Various	
1	R3	2.32k Ω , 1%, 1/8W	Various	
1	R4	1k Ω , 1%, 1/8W	Various	
1	R5	10 Ω , 5%, 1/8W	Various	
1	U1	SC1150CS	SEMTECH	

March 11, 1998

CHARACTERISTIC CURVES

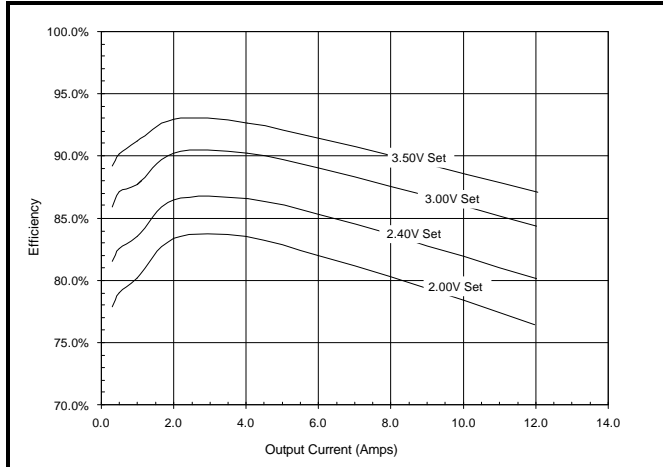
SC1150 Efficiency in Application circuit 16935E



Application circuit 16935E Ripple, 3.1V, 10A out

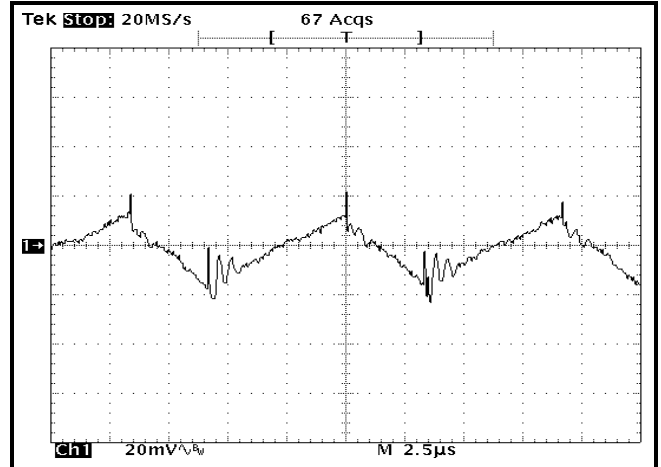

Application circuit 16935E Transient Response, 3.1V, 0.3A to 10A

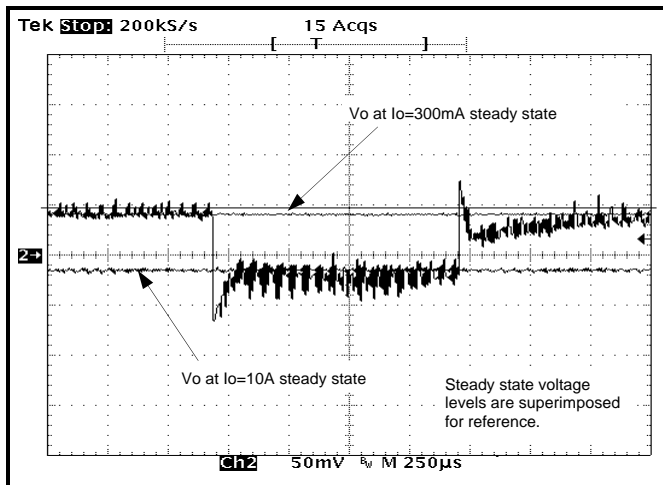

SC1150 Regulation in Application circuit 16935E

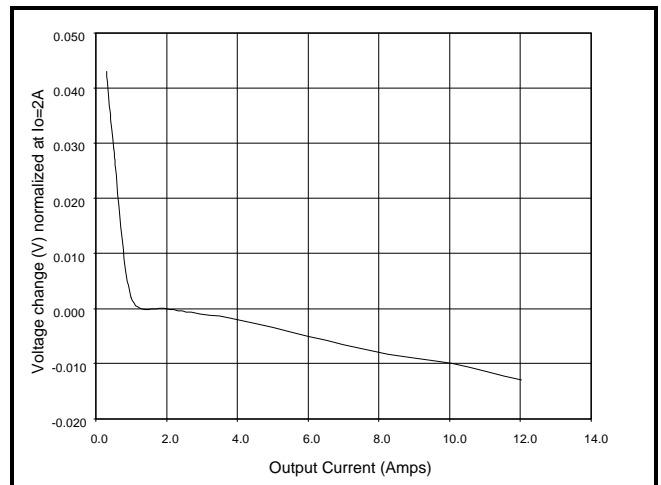

March 11, 1998

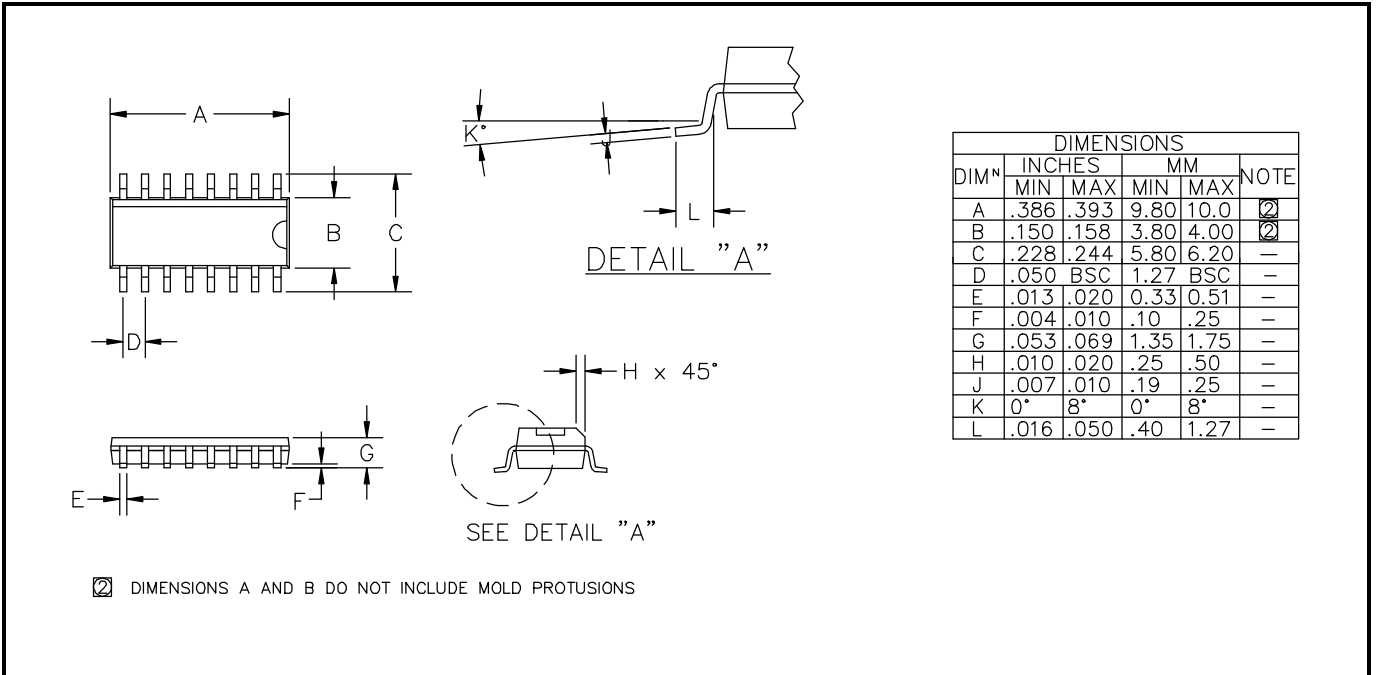
OUTLINE DRAWING SO-16

LAND PATTERN SO-16
