

MOTOROLA SEMICONDUCTOR TECHNICAL DATA

T-33-17

MPS-U60

NOT RECOMMENDED FOR NEW DESIGNS

PNP SILICON ANNULAR TRANSISTOR

Designed for general-purpose applications requiring high breakdown voltages, low saturation voltages and low capacitance.

Complement to NPN Type MPS-U10

PNP SILICON HIGH VOLTAGE TRANSISTOR

MAXIMUM RATINGS

Rating	Symbol	Value	Unit
Collector-Emitter Voltage	V _{CEO}	300	V _{dc}
Collector-Base Voltage	V _{CB}	300	V _{dc}
Emitter-Base Voltage	V _{EB}	5.0	V _{dc}
Collector Current - Continuous	I _C	500	mA _{dc}
Total Power Dissipation @ T _A = 25°C	P _D	1.0	Watt
Derate above 25°C		8.0	mW/°C
Total Power Dissipation @ T _C = 25°C	P _D	10	Watts
Derate above 25°C		80	mW/°C
Operating and Storage Junction Temperature Range	T _J , T _{stg}	-55 to +150	°C

THERMAL CHARACTERISTICS

Characteristic	Symbol	Max	Unit
Thermal Resistance, Junction to Case	R _{θJC}	12.5	°C/W
Thermal Resistance, Junction to Ambient	R _{θJA} (1)	125	°C/W

ELECTRICAL CHARACTERISTICS (T_A = 25°C unless otherwise noted)

Characteristic	Symbol	Min	Max	Unit
----------------	--------	-----	-----	------

OFF CHARACTERISTICS

Collector-Emitter Breakdown Voltage (2) (I _C = 1.0 mA _{dc} , I _E = 0)	V _{(BR)CEO}	300	-	V _{dc}
Collector-Base Breakdown Voltage (I _C = 100 μA _{dc} , I _E = 0)	V _{(BR)CBO}	300	-	V _{dc}
Emitter-Base Breakdown Voltage (I _E = 10 μA _{dc} , I _C = 0)	V _{(BR)EBO}	5.0	-	V _{dc}
Collector Cutoff Current (V _{CB} = 200 V _{dc} , I _E = 0)	I _{CBO}	-	0.2	μA _{dc}
Emitter Cutoff Current (V _{BE} = 3.0 V _{dc} , I _C = 0)	I _{EBO}	-	0.1	μA _{dc}

ON CHARACTERISTICS

DC Current Gain (2) (I _C = 1.0 mA _{dc} , V _{CE} = 10 V _{dc}) (I _C = 10 mA _{dc} , V _{CE} = 10 V _{dc}) (I _C = 30 mA _{dc} , V _{CE} = 10 V _{dc})	h _{FE}	25 30 30	-	-
Collector-Emitter Saturation Voltage (I _C = 20 mA _{dc} , I _E = 2.0 mA _{dc})	V _{CE(sat)}	-	0.75	V _{dc}
Base-Emitter Saturation Voltage (I _C = 20 mA _{dc} , I _E = 2.0 mA _{dc})	V _{BE(sat)}	-	0.9	V _{dc}

DYNAMIC CHARACTERISTICS

Current Gain-Bandwidth Product (2) (I _C = 10 mA _{dc} , V _{CE} = 20 V _{dc} , f = 100 MHz)	f _T	60	-	MHz
Collector-Base Capacitance (V _{CB} = 20 V _{dc} , I _E = 0, f = 1.0 MHz)	C _{cb}	-	8.0	pF

(1) R_{θJA} is measured with the device soldered into a typical printed circuit board.

(2) Pulse Test: Pulse Width < 300 μs, Duty Cycle < 2.0%.

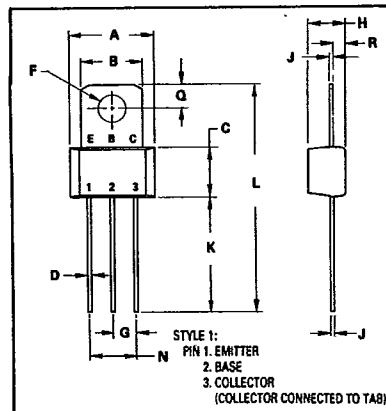
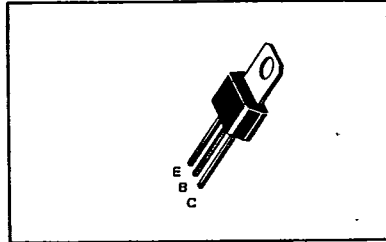

NOTE:
1. LEADS WITHIN 0.15 mm(0.006) TOTAL OF TRUE POSITION AT CASE, AT MAXIMUM MATERIAL CONDITION.

DIM	MILLIMETERS		INCHES	
	MIN	MAX	MIN	MAX
A	9.14	9.53	0.360	0.375
B	6.60	7.24	0.260	0.285
C	5.41	5.66	0.213	0.223
D	0.38	0.53	0.015	0.021
F	3.19	3.33	0.125	0.131
G	2.54 BSC 0.100 BSC			
H	3.94	4.19	0.155	0.165
J	0.36	0.41	0.014	0.016
K	11.63	12.70	0.458	0.500
L	24.58	25.53	0.968	1.005
N	5.08 BSC 0.200 BSC			
Q	2.30	2.69	0.094	0.106
R	1.14	1.40	0.045	0.055

CASE 152-02

T-33-17

FIGURE 1 - DC CURRENT GAIN

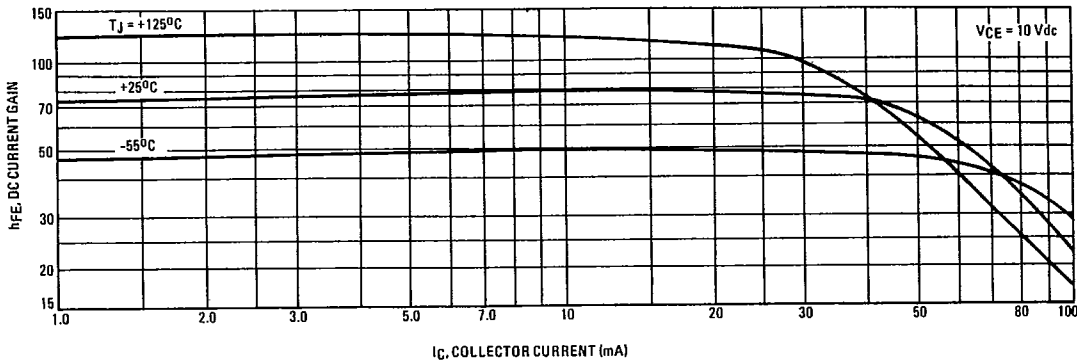

FIGURE 2 - CAPACITANCES

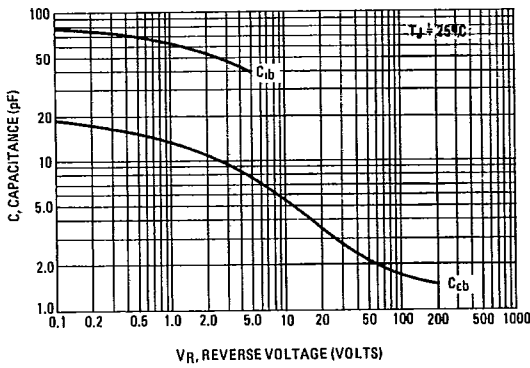

FIGURE 3 - CURRENT-GAIN-BANDWIDTH PRODUCT

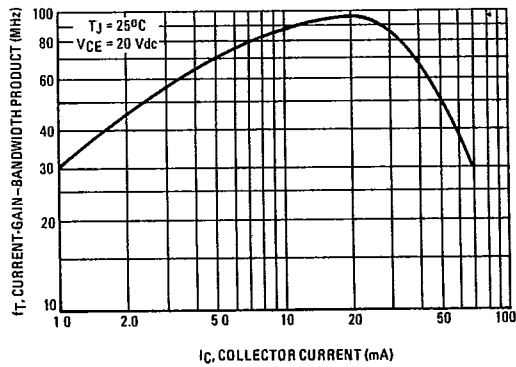

FIGURE 4 - "ON" VOLTAGES

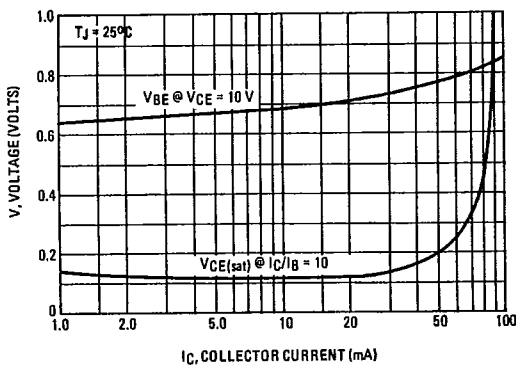
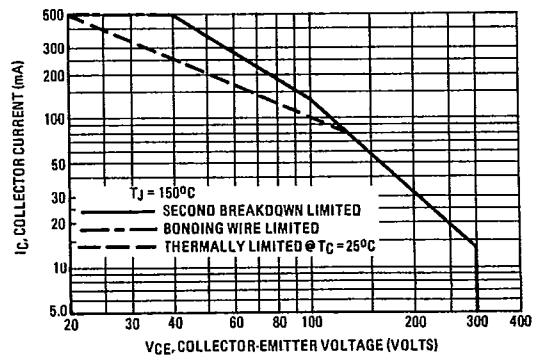

FIGURE 5 - DC SAFE OPERATING AREA



3