

FEATURES

- 500ps typical propagation delay
- Differential ECL output
- PNP TTL input for minimal loading
- Flow-through pinouts
- Available in 8-pin SOIC package

DESCRIPTION

The SY100ELT24 is a TTL-to-differential ECL translator. Because ECL levels are used, a +5V, -5.2V (or -4.5V) and ground are required. The small outline 8-lead SOIC package and the single gate of the ELT24 makes it ideal for those applications where performance, space and low power are at a premium.

PIN CONFIGURATION/BLOCK DIAGRAM

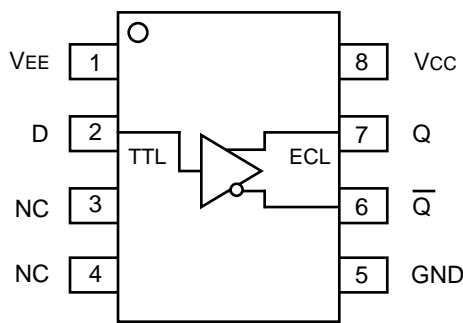

**SOIC
TOP VIEW**

PIN NAMES

Pin	Function
Q, Q̄	Differential ECL Output
D	TTL Input
Vcc	Positive Supply
VEE	Negative Supply
GND	Ground

ABSOLUTE MAXIMUM RATINGS⁽¹⁾

Symbol	Parameter	Value	Unit
V _{CC}	Power Supply Voltage	-0.5 to +7.0	V
V _I	TTL Input Voltage	-0.5 to V _{CC}	V
I _I	TTL Input Current	-30 to +5.0	mA
I _{OUT}	ECL Output Current — Continuous — Surge	50 100	mA
T _{store}	Storage Temperature	-65 to +150	°C
T _A	Operating Temperature	-40 to +85	°C

TRUTH TABLE

D	Q	\bar{Q}
H	H	L
L	L	H
Open	H	L

NOTE:

- Permanent device damage may occur if ABSOLUTE MAXIMUM RATINGS are exceeded. This is a stress rating only and functional operation is not implied at conditions other than those detailed in the operational sections of this data sheet. Exposure to ABSOLUTE MAXIMUM RATING conditions for extended periods may affect device reliability.

DC ELECTRICAL CHARACTERISTICS

V_{CC} = 4.5V to 5.5V; V_{EE} = -4.2V to -5.5V

Symbol	Parameter	T _A = -40°C		T _A = 0°C		T _A = +25°C		T _A = +85°C		Unit	Condition
		Min.	Max.	Min.	Max.	Min.	Max.	Min.	Max.		
I _{CC}	Power Supply Current	—	10	—	10	—	10	—	10	mA	—
I _{EE}	Power Supply Current	—	20	—	20	—	20	—	20	mA	No output load

AC ELECTRICAL CHARACTERISTICS

V_{CC} = 4.5V to 5.5V; V_{EE} = -4.2V to -5.5V

Symbol	Parameter	T _A = -40°C		T _A = 0°C		T _A = +25°C			T _A = +85°C		Unit	Condition
		Min.	Max.	Min.	Max.	Min.	Typ.	Max.	Min.	Max.		
t _{PLH} t _{PHL}	Propagation Delay	300	900	300	900	300	500	900	300	900	ps	50Ω to -2.0V
t _r t _f	Output Rise/Fall Time 20% to 80%	200	700	200	700	200	300	700	200	700	ps	50Ω to -2.0V
f _{MAX}	Maximum Input Frequency	200	—	200	—	200	—	—	200	—	MHz	

TTL DC ELECTRICAL CHARACTERISTICS

VCC = 4.5V to 5.5V; VEE = -4.2V to -5.5V

Symbol	Parameter	TA = -40°C		TA = 0°C		TA = +25°C		TA = +85°C		Unit	Condition
		Min.	Max.	Min.	Max.	Min.	Max.	Min.	Max.		
V _{IH}	Input HIGH Voltage	2.0	—	2.0	—	2.0	—	2.0	—	V	—
V _{IL}	Input LOW Voltage	—	0.8	—	0.8	—	0.8	—	0.8	V	—
I _{IH}	Input HIGH Current	—	20 100	—	20 100	—	20 100	—	20 100	μA	V _{IN} = 2.7V V _{IN} = V _{CC}
I _{IL}	Input LOW Current	—	-0.6	—	-0.6	—	-0.6	—	-0.6	mA	V _{IN} = 0.5V
V _{IK}	Input Clamp Voltage	—	-1.2	—	-1.2	—	-1.2	—	-1.2	V	I _{IN} = -18mA

ECL DC ELECTRICAL CHARACTERISTICS

VCC = 4.5V to 5.5V; VEE = -4.2V to -5.5V

Symbol	Parameter	TA = -40°C		TA = 0°C		TA = +25°C		TA = +85°C		Unit	Condition
		Min.	Max.	Min.	Max.	Min.	Max.	Min.	Max.		
V _{OH}	Output HIGH Voltage	-1085	-880	-1025	-880	-1025	-880	-1025	-880	mV	50Ω to -2.0V
V _{OL}	Output LOW Voltage	-1830	-1555	-1810	-1620	-1810	-1620	-1810	-1620	mV	50Ω to -2.0V

PRODUCT ORDERING CODE

Ordering Code	Package Type	Operating Range
SY100ELT24ZC	Z8-1	Commercial
SY100ELT24ZCTR	Z8-1	Commercial

8 LEAD SOIC .150" WIDE (Z8-1)

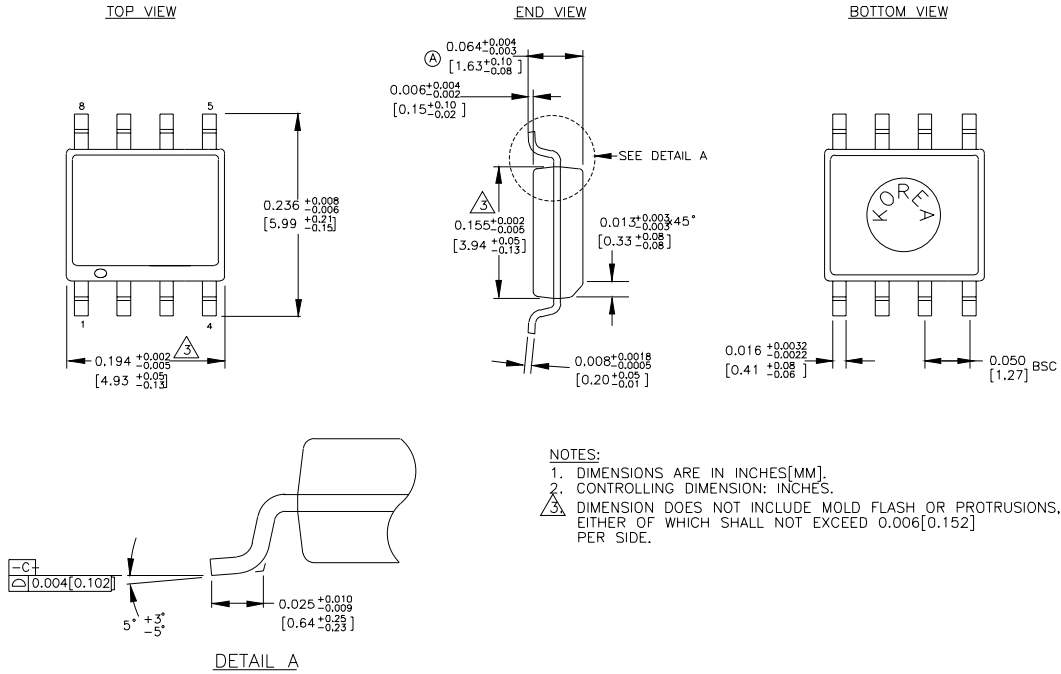

Rev.03

MICREL-SYNERGY 3250 SCOTT BOULEVARD SANTA CLARA CA 95054 USA

TEL + 1 (408) 980-9191 FAX + 1 (408) 914-7878 WEB <http://www.micrel.com>

This information is believed to be accurate and reliable, however no responsibility is assumed by Micrel for its use nor for any infringement of patents or other rights of third parties resulting from its use. No license is granted by implication or otherwise under any patent or patent right of Micrel Inc.

© 2000 Micrel Incorporated