

PRELIMINARY

Notice ; This is not a final specification.
some parametric limits are subject to change.

MITSUBISHI SEMICONDUCTORS
(SOUND PROCDSOR ICs)

M65851FP



SINGLE CHIP KARAOKE PROCESSOR

DESCRIPTION

*The M65851FP is an LSI that not only contains circuits (echo and key control) necessary for Karaoke but also improves other peripheral functions.

*This IC has full peripheral functions including vocal cut, phase shifter, equalizer, detection of intervals between songs, digital surround, and Karaoke scoring. It is therefore suitable not only for dedicated Karaoke units but also for radio cassette tape recorders, TV, VCR, and miniature unit audio systems with Karaoke function.

FEATURES

- *Capable of composing echo and key control circuits necessary for Karaoke system for Karaoke system with a single chip
- *Echo circuit is capable of supporting digital surround by adopting 16Kbit RAM built-in digital delay
- *17steps of -8 to +8 for key control (1step is equivalent to a half tone)
- *Karaoke entertainment functions such as Karaoke scoring, vocal cut, equalizer, phase shifter, detection of intervals between songs, and magic voice functions
- *Generation of unnecessary radiation is avoided because clock's built-in current-control oscillation circuit keeps clock effects inside the clock
- *Built-in automatic reset circuit activated with power turned on
- *5V single power supply

Outline 80P6N-A

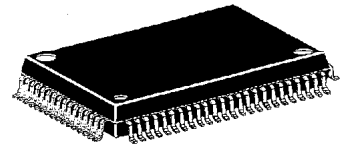

0.8mm pitch QFP
(20.0mmx14.0mmx2.8mm)

RECOMMENDED OPERATING CONDITION

Supply voltage range.....Vcc=4.5~5.5V

Rated supply voltage.....Vcc=5V

SYSTEM CONFIGURATION

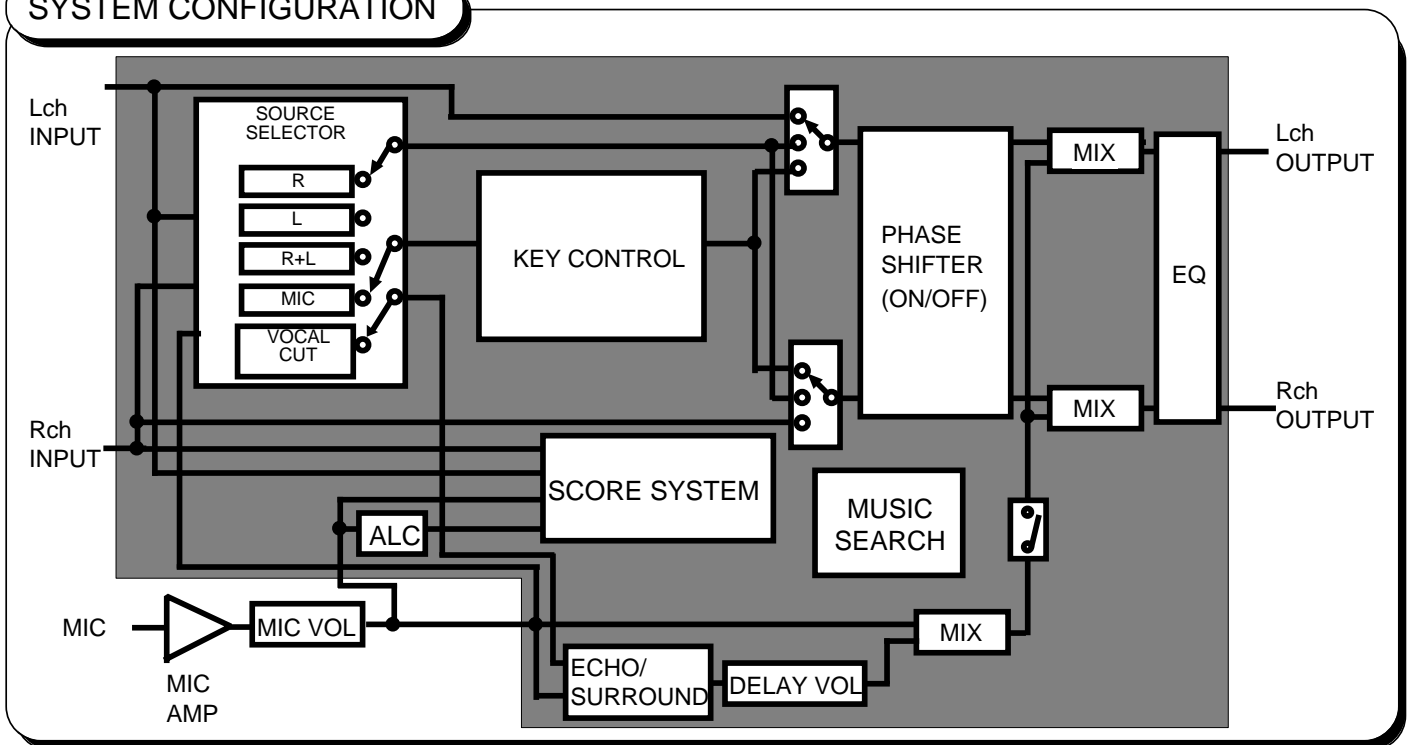

D-65851-65D

PRELIMINARY
 Notice ; This is not a final specification.
 some parametric limits are subject to change.

MITSUBISHI SEMICONDUCTORS
 (SOUND PROCSSOR ICs)

M65851FP



PIN CONFIGURATION

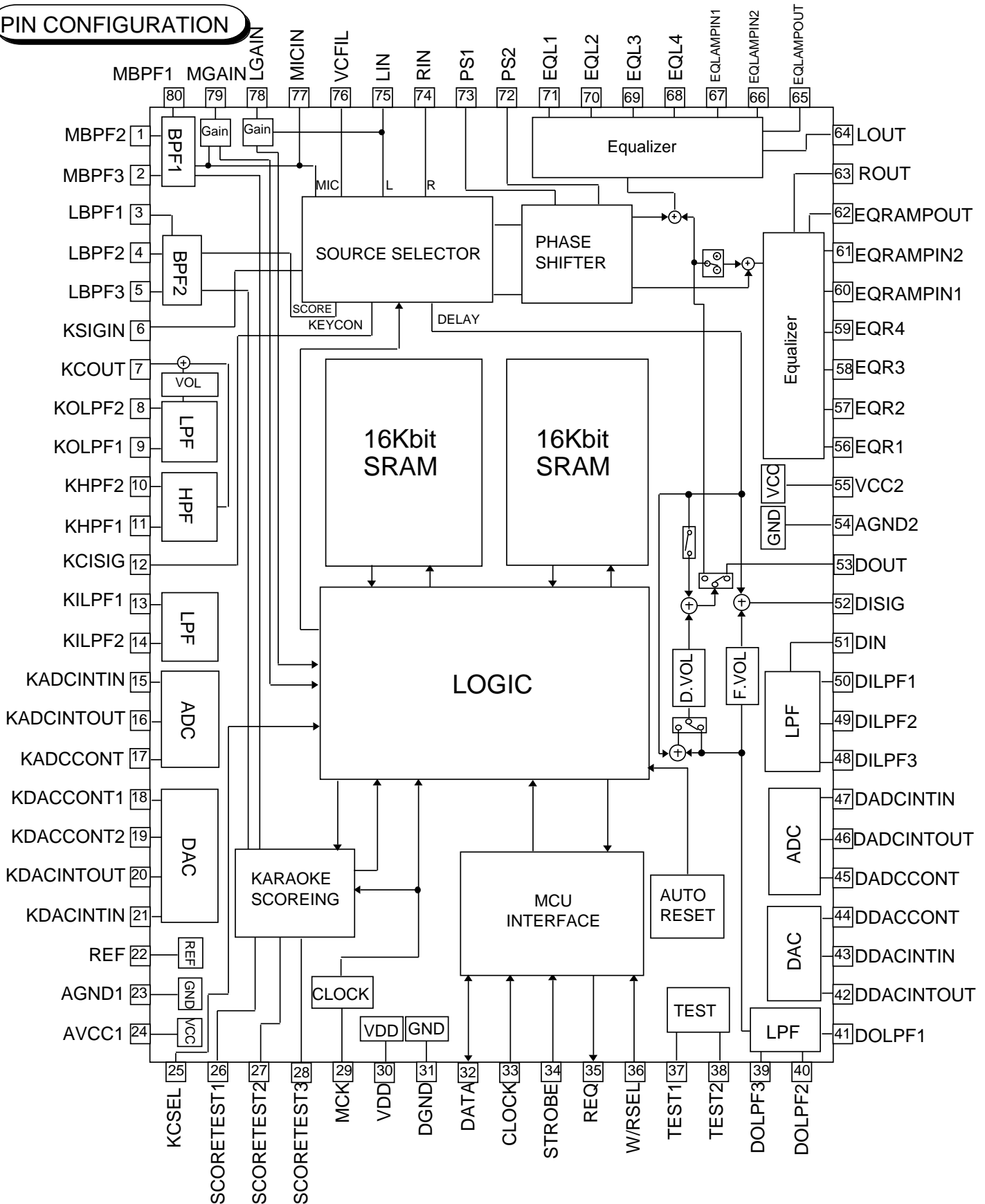

PRELIMINARY
 Notice ; This is not a final specification.
 some parametric limits are subject to change.

MITSUBISHI SEMICONDUCTORS
 (SOUND PROCDSOR ICs)

M65851FP



PIN DESCRIPTION

Pin No.	Symbol	Name	I/O	Function
1	MBPF2	Microphone band pass filter2	I	Composes band pass filter for Karaoke scoring (For microphone signal)
2	MBPF3	Microphone band pass filter3	O	
3	LBPF1	Line band pass filter1	-	Composes band pass filter for Karaoke scoring (For reference signal)
4	LBPF2	Line band pass filter2	I	
5	LBPF3	Line band pass filter3	O	
6	KSIGIN	Key controled signal input	I	Key controled signal input
7	KCOUT	Key control output	O	Key control signal output
8	KOLPF2	Low-pass filter 2 output	O	Post-filter after D/A conversion for key control
9	KOLPF1	Low-pass filter 1 input	I	
10	KHPF2	High-pass filter 2 output	O	High-pass passage filter for high-pass through
11	KHPF1	High-pass filter 1 input	I	
12	KCISIG	Key control signal output	-	Output by selecting from L,L+R/2,L-R,and microphone input
13	KILPF1	Low-pass filter 1 input	I	Pre-filter after D/A conversion for key control
14	KILPF2	Low-pass filter 2output	O	
15	KADCINTIN	A/D integrator input	I	Composes an A/D conversion integrator with external C
16	KADCINTOUT	A/D integrator output	O	
17	KADCCONT	A/D control	-	
18	KDACCONT1	D/A control 1	-	Composes a D/A conversion integrator with external C
19	KDACCONT2	D/A control 2	-	
20	KDACINTOUT	D/A integrator output	O	

PRELIMINARY

Notice ; This is not a final specification.
some parametric limits are subject to change.

MITSUBISHI SEMICONDUCTORS
(SOUND PROCSSOR ICs)

M65851FP



Pin No.	Symbol	Name	I/O	Function	
21	KDACINTIN	D/A integrator input	I	Composes a D/A conversion integrator with external C	
22	REF	Reference	-	Analog reference voltage $\cong 1/2V_{cc}$	
23	AGND1	Analog GND1	-		
24	VCC1	Analog power supply1	-	5V	
25	KCSEL	Key control selector	I:CMOS20k ↓	Controls the Key selector key control mode or not	
26	SCORETEST1	Score test selector1	I:CMOS20k ↓	Score test selector ; normally set to L level	
27	SCORETEST2	Score test selector2	I:CMOS20k ↓		
28	SCORETEST3	Score test selector3	O:CMOS	Score test selector ; normally no connect	
29	MCK	Clock control	-	External R controls built-in clock generator circuit	
30	VDD	Digital Power supply	-		
31	DGND	Digital GND	-		
32	DATA	Serial data	I:CMOSShumitt 50k ↓ O:CMOS	Micro computer interface	Serial data input/output
33	CLOCK	Clock control	I:CMOSShumitt 50k ↓		Shift clock output
34	STROBE	Strobe	I:CMOSShumitt 50k ↓		Strobe output
35	REQ	Request	O:CMOS		Request output
36	W/RSEL	Write-Read selector	I:CMOSShumitt 50k ↓		Control the selector write/read
37	TEST1	Test signal control input1	I:CMOS20k ↓	Test input pin ; normally set to L	
38	TEST2	Test signal control input2	I:CMOS20k ↓		
39	DOLPF3	Low-pass filter 3 output	O	Post-filter after D/A conversion for digital delay	
40	DOLPF2	Low-pass filter 2 input	I		

PRELIMINARY
 Notice ; This is not a final specification.
 some parametric limits are subject to change.

MITSUBISHI SEMICONDUCTORS
 (SOUND PROCSSOR ICs)

M65851FP



Pin No.	Symbol	Name	I/O	Function
41	DOLPF1	Low-pass filter 1 input	-	Post-filter after D/A conversion for digital delay
42	DDACINTOUT	D/A integrator output	O	Composes a D/A conversion integrator with external
43	DDACINTIN	D/A integrator input	I	
44	DDACCONT	D/A control	-	
45	DADCCONT	A/D control	-	Composes a A/D conversion integrator with external
46	DADCINTOUT	A/D integrator output	O	
47	DADCINTIN	A/D integrator input	I	
48	DILPF3	Low-pass filter 3 output	O	Pre-filter before A/D conversion for digital delay
49	DILPF2	Low-pass filter 2 input	I	
50	DILPF1	Low-pass filter 1 input	-	
51	DIN	Delay select signal input	I	Outputs after selection of echo/surround input signal
52	DISIG	Delay select signal output	O	
53	DOUT	Delay signal output	O	Delay signal output
54	AGND2	Analog GND2	-	
55	VCC2	Analog Power supply2	-	
56	EQR1	Rch equalizer adjustment C1	-	Composes external C for the adjustment of Rch equalizer characteristics (bass and treble)
57	EQR2	Rch equalizer adjustment C2	-	
58	EQR3	Rch equalizer adjustment C3	-	
59	EQR4	Rch equalizer adjustment C4	-	
60	EQRAMPIN1	Rch equalizer input 1	I	

PRELIMINARY
 Notice ; This is not a final specification.
 some parametric limits are subject to change.

MITSUBISHI SEMICONDUCTORS
 (SOUND PROCDSOR ICs)

M65851FP



Pin No.	Symbol	Name	I/O	Function
61	EQRAMPIN2	Rch equalizer input 2	I	Composes external C for the adjustment of Rch equalizer characteristics (bass and treble)
62	EQRAMPOUT	Rch equalizer output	O	
63	ROUT	Rch output	O	Rch mixing output
64	LOUT	Lch output	O	Lch mixing output
65	EQLAMPOUT	Lch equalizer output	O	Composes external C for the adjustment of Lch equalizer characteristics (bass and treble)
66	EQLAMPIN2	Lch equalizer input 2	I	
67	EQLAMPIN1	Lch equalizer input 1	I	
68	EQL4	Lch equalizer adjustment C4	-	
69	EQL3	Lch equalizer adjustment C3	-	
70	EQL2	Lch equalizer adjustment C2	-	
71	EQL1	Lch equalizer adjustment C1	-	
72	PS2	Phase shift input 2	I	Determines a constant at time of phase shift
73	PS1	Phase shift input 1	I	
74	RIN	Rch line input	I	Rch line input
75	LIN	Lch line input	I	Lch line input
76	VCFIL	Vocal cut filter	I	Processes frequencies lower than the vocal band
77	MICIN	Microphone input	I	Microphone input
78	LGAIN	Line input gain control	I	Set gain for the no music detection
79	MGAIN	Microphone input gain control	I	Set gain for the microphone detection
80	MBPF1	Microphone band pass filter2	-	Composes band pass filter for Karaoke scoring (For microphone signal)

PRELIMINARY
 Notice ; This is not a final specification.
 some parametric limits are subject to change.

MITSUBISHI SEMICONDUCTORS
 (SOUND PROCSSOR ICs)

M65851FP



ABSOLUTE MAXIMUM RATINGS

Symbol	Name	Test conditions	Ratings	Units
Vcc	Supply voltage		6.0	V
Vi	Circuit current		-0.3~Vcc+0.3	V
Pd	Input Voltage		815	W
Topr	Operating temperature		-20~+75	°C
Tstg	Storage temperature		-40~+125	°C

RECOMMENDED OPERATING CONDITION

Symbol	Parameter	Test conditions	Limits			Units
			Min	Typ	Max	
VCC	Analog supply voltage		4.5	5	5.5	V
VDD	Digital supply voltage		4.5	5	5.5	V
VCC-VDD	Analog-Digital voltage margin		-0.3	0	0.3	V
V _{IL}	L input level	(25)(26)(27)(28) (37)(38) pin	0	-	0.3VDD	V
		(32)(33)(34)(36) pin	0	-	0.8	V
V _{IH}	H input level	(25)(26)(27)(28) (37)(38) pin	0.7VDD	-	VDD	V
		(32)(33)(34)(36) pin	VDD-1	-	VDD	V

PRELIMINARY

Notice ; This is not a final specification.
some parametric limits are subject to change.

MITSUBISHI SEMICONDUCTORS
(SOUND PROCDCSSOR ICs)

M65851FP



ELECTRICAL CHARACTERISTICS

(Vcc=5V, f=1kHz, vi=100mVrms, F0, Ta=25°C Unless otherwise noted)

Symbol	Parameter	Test conditions	Limits			Unit	
			Min	Typ	Max		
TOTAL	Icc	Circuit current	No signal provided	25	60	90	mA
	fck	Clock frequency		6.8	8	9.2	MHz
	RID	Pulldown resistance	(25)(26)(27)(28) (37)(38) pin	10	20	40	k
			(32)(33)(34)(36) pin	25	50	100	k
	IOH	"H"Output current	(32)(35)pin VOH=4.0V	-	-20	-10	mA
	IOL	"L"Output current	(32)(35)pin VOL=1.0V	20	34	-	mA
KEY CONTROL	Gv	Gain between input and output	VOL=0dB	- 3	0	+ 3	dB
	THD	Output distortion	Vo=100mVrms,30kHz L.P.F	-	1.3	3	%
	No	Output noise voltage	JIS-A	-	- 80	- 65	dBV
	Vomax	Maximum output voltage	THD=10%	0.7	1.0	-	Vrms
	VOLATTmax	Maximum volume attenuation	Gain=-	-	-60	-40	dB
Digital Delay	Td	Delay time	Sets 10msec with microcomputer	4.2	10.2	16.2	msec
			Sets 15msec with microcomputer	8.4	15.4	22.4	
			Sets 20msec with microcomputer	13.5	20.5	27.5	
			Sets 30msec with microcomputer	19.7	28.7	37.7	
			Sets 50msec with microcomputer	40.2	49.2	58.2	
			Sets 100msec with microcomputer	86.3	98.3	110.3	
			Sets 130msec with microcomputer	116	131	146	
			Sets 150msec with microcomputer	128	148	168	
			Sets 200msec with microcomputer	177	197	217	

PRELIMINARY

Notice ; This is not a final specification.
some parametric limits are subject to change.

MITSUBISHI SEMICONDUCTORS
(SOUND PROCSSOR ICs)

M65851FP



(Vcc=5V, f=1kHz, vi=100mVrms, F0, Ta=25°C Unless otherwise noted)

Symbol	Parameter	Test conditions	Limits			Unit	
			Min	Typ	Max		
DIGITAL DELAY	Gv	Gain between input and output	VOL=0dB	-3	0	+3	dB
	THD	Output distortion	Td=10,15,20msec, 30kHz LPF	—	0.3	0.6	%
			Td=30msec, 30kHz LPF	—	0.5	1.0	
			Td=50msec, 30kHz LPF	—	0.7	1.4	
			Td=100msec, 30kHz LPF	—	1.0	2.0	
			Td=150msec, 30kHz LPF	—	1.5	3.0	
			Td=200msec, 30kHz LPF	—	2.0	4.0	
	Vomax	Maximum output voltage	30kHz LPF, THD=10%	0.7	1.0	—	Vrms
	No	Output noise voltage	Td=10,15,20,30,50msec, Vi=0mVrms JIS-A	—	-92	-80	dBV
			Td=100msec, Vi=0mVrms JIS-A	—	-87	-72	
Td=130msec,150msec Vi=0mVrms ,JIS-A			—	-85	-70		
Td=200msec, Vi=0mVrms JIS-A			—	-82	-67		
VOLATTmax	Maximum volume attenuation	Delay volume Gain=-	—	-60	-40	dB	
		Feed back volume Gain=-	—	-60	-40	dB	
LINE	Gv	Gain between input and output	30kHz LPF, upon key control through	- 3	0	+ 3	dB
	THD	Output distortion	30kHz LPF, upon key control through	—	0.05	0.1	%
	Vomax	Maximum output voltage	30kHz LPF, THD=10% upon key control through	1.2	1.8	—	Vrms
	No	Output noise voltage	JIS-A, upon key control through	—	-95	-88	dBV

PRELIMINARY
 Notice ; This is not a final specification.
 some parametric limits are subject to change.

MITSUBISHI SEMICONDUCTORS
 (SOUND PROCSSOR ICs)

M65851FP



(Vcc=5V, f=1kHz, vi=100mVrms, F0, Ta=25°C Unless otherwise noted)

Symbol	Parameter	Test conditions	Limits			Unit	
			Min	Typ	Max		
LINE	CS	Channel separation	upon key control through Lin=400Hz, Rout JIS-A	—	-70	-50	dB
	Zi	Input impedance		10	20	40	k
	Grej	Vocal removal ratio	Vocal cut	14	18	—	dB
EQ;BASS,TREBLE	GBBmax	Maximum bass boost volume	f=100Hz	9	12	15	dB
	GBCmax	Maximum bass cut volume	f=100Hz	-15	-12	-9	
	GTBmax	Maximum treble boost volume	f=10kHz	9	12	15	
	GTCmax	Maximum treble cut volume	f=10kHz	-15	-12	-9	

PRELIMINARY

Notice ; This is not a final specification.
some parametric limits are subject to change.

MITSUBISHI SEMICONDUCTORS
(SOUND PROCSSOR ICs)

M65851FP



FEATURES

M65851FP provides the following functions and can configurate all Karaoke functions with only a single chip.

Function	Explanation	Usable or not		Notes
		Key set mode	not key set mode	
1 Digital echo	Built in 16KSRAM Delay time (changeable) 100ms,130ms,150ms,200ms	○	○	At Key set mode Capable of use echo or surround Not key set mode Capable of use both echo and surround
2 Digital key control	Built in 16KSRAM -8 ~ +8 17 steps	○	×	
3 Digital Surround	Built in 16KSRAM Digital Surround 10ms ~ 50ms 5 kinds	△ Switch with the Echo	○	
4 Phase shifter surround	Changeable the effect thanks to the external R	○	○	Capable of use both key control and echo
5 Equalizer	Bass/Treble -12dB ~ +12dB/2dB 13 steps changeable	○	○	Bass; Resonance type Treble ; Filter type
6 Source selector	Provided all multiple voice soft, L,R,(L+R)/2, VOCAL CUT L-R(for Digital Surround) Key control bypass	○	○	
7 Scoring function	Scoring the Mic vocal input	○	○	Compare the reference vocal and mic vocal frequency
8 Help vocal function	At the mic vocal is nothing , reference vocal is mixed output.	○	○	
9 Voice key control	Input the mic voice to key control (change voice tone)	○	×	At Key set mode capable to use voice key control or key control
10 Music search	Detect to line input level	○	○	At music input is nothing ,key control level is reset automatically
11 Others	MCU Inter face Current control type oscillation circuit Automatic mute Automatic reset	○	○	

PRELIMINARY

Notice ; This is not a final specification.
some parametric limits are subject to change.

MITSUBISHI SEMICONDUCTORS
(SOUND PROCSSOR ICs)

M65851FP



Delay Block

Delay Block provides a delay signal which using digital echo or digital surround.

1.Constitution

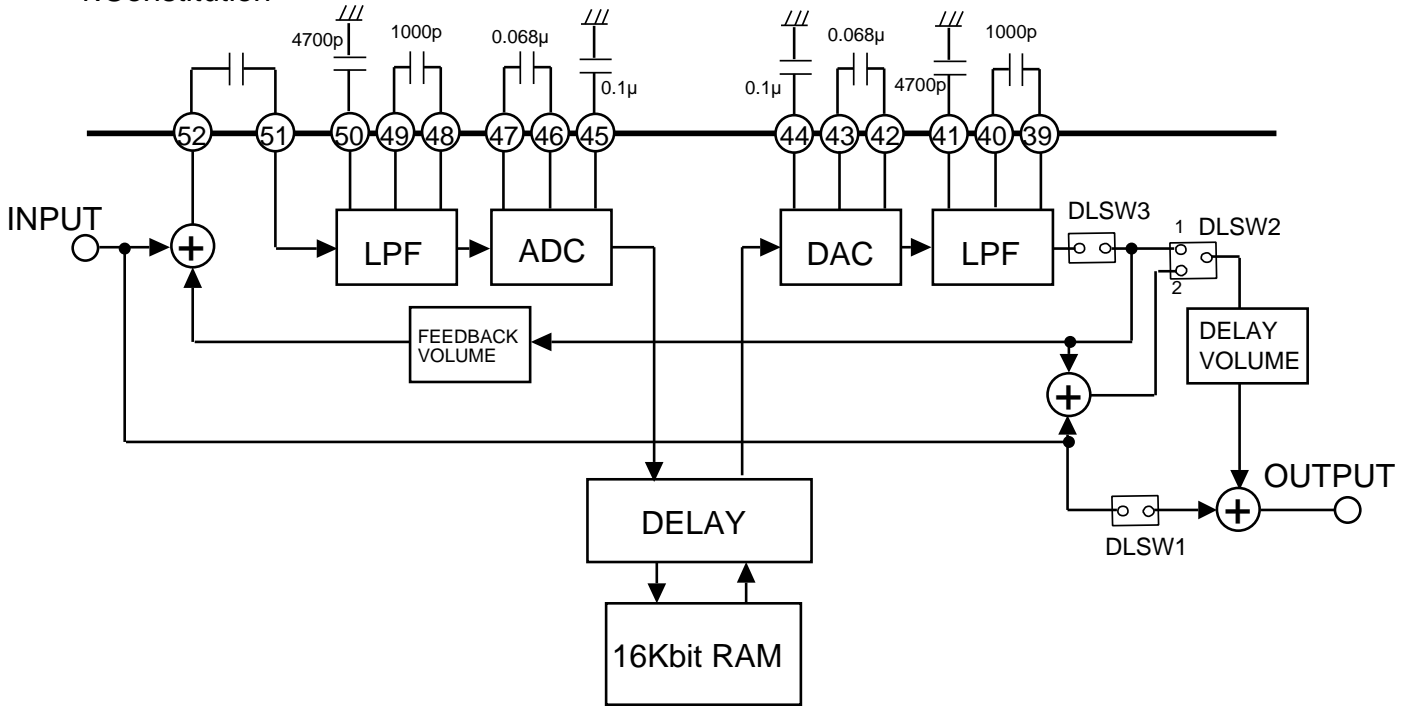

2.Function

①Delay time

Capable to set the follow delay time;

Mode	Delay time
Echo	100,130,150,200msec
Surround	10,15,20,30,50msec

②Switch mode

Mode		DLSW1	DLSW2
Echo	1	ON	1
	2	OFF	2
Surround		OFF	1

Echo"1"
Set the echo volume using the delay volume(Change the delay signal gain)
Echo"2"
Set the microphone volume using the delay volume
(Change the delay signal+input signal gain)

PRELIMINARY

Notice ; This is not a final specification.
some parametric limits are subject to change.

MITSUBISHI SEMICONDUCTORS
(SOUND PROCSSOR ICs)

M65851FP



Delay signal Mute	DLSW3
MUTE OFF	ON
MUTE ON	OFF

③ Input/ output LPF

Input/output LPF is formed following block.

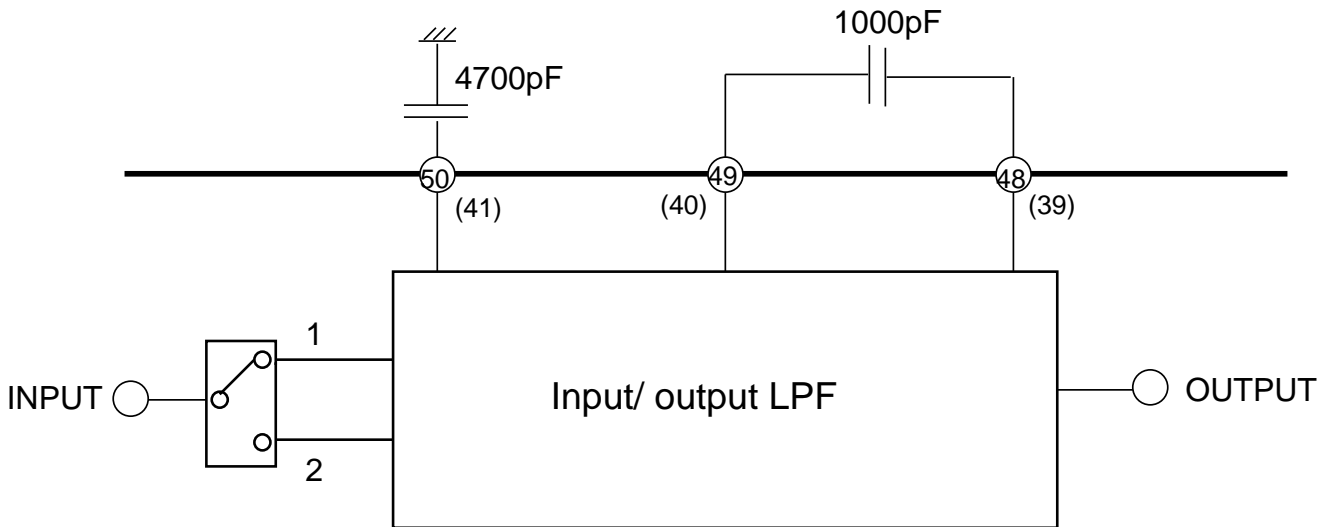

Mode	Switch conditions	Cut off frequency
Echo	1	3.0kHz
Surround	2	7.0kHz

④ Volume

Volume	Mode
Delay volume	+6dB ~ -12dB / 3dB step and - 8 level
Feedback volume	-2dB ~ -6dB / 1dB step and -8dB,-10dB,- 8 level

PRELIMINARY

Notice ; This is not a final specification.
some parametric limits are subject to change.

MITSUBISHI SEMICONDUCTORS
(SOUND PROCSSOR ICs)

M65851FP



Key Control Block

It can be changed the key of KARAOKE accompaniment.
And it can change a microphone voice which like a monkey voice.
it also can use digital echo block at not key set mode.

1.Key control condition ,key control set mode or not

Ⓔ KCSEL	Key control condition
L	Key control set mode
H	Not key control set mode

2.Constitution

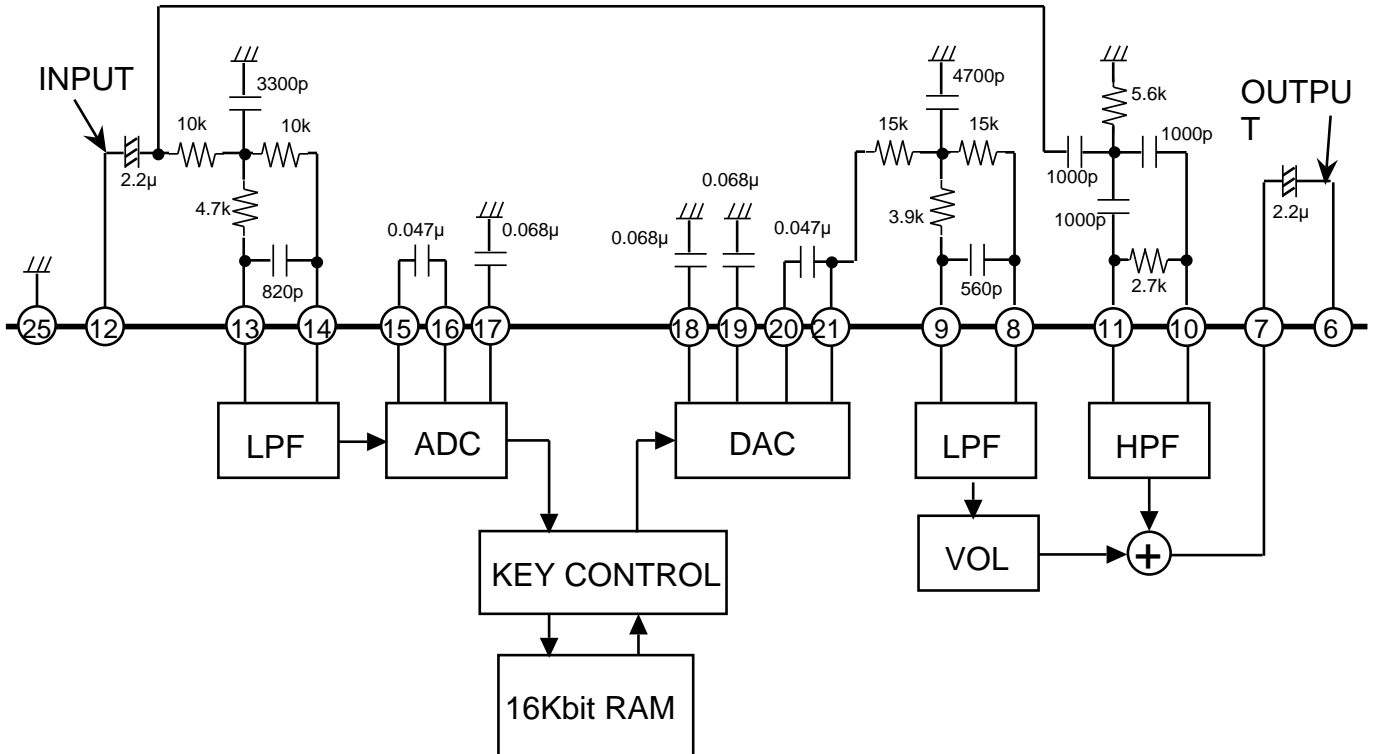

3.Function

①Key change level

Key change level (1step is half tone)	KEY UP									KEY DOWN							
	+8	+7	+6	+5	+4	+3	+2	+1	0	-1	-2	-3	-4	-5	-6	-7	-8

PRELIMINARY

Notice ; This is not a final specification.
some parametric limits are subject to change.

MITSUBISHI SEMICONDUCTORS
(SOUND PROCSSOR ICs)

M65851FP



②Volume

It set the key control signal gain.
+4dB~-6dB/2dB step and -10dB, - 8 level

③Key control level automatic reset

When music search detects no signal ,key control level is automatic changed normal (0) level.

(Provides ON/OFF switch with MCU interface)

4.Echo Block (using key control block)

At not key control set mode,digital echo is able to use ,when the following block using.

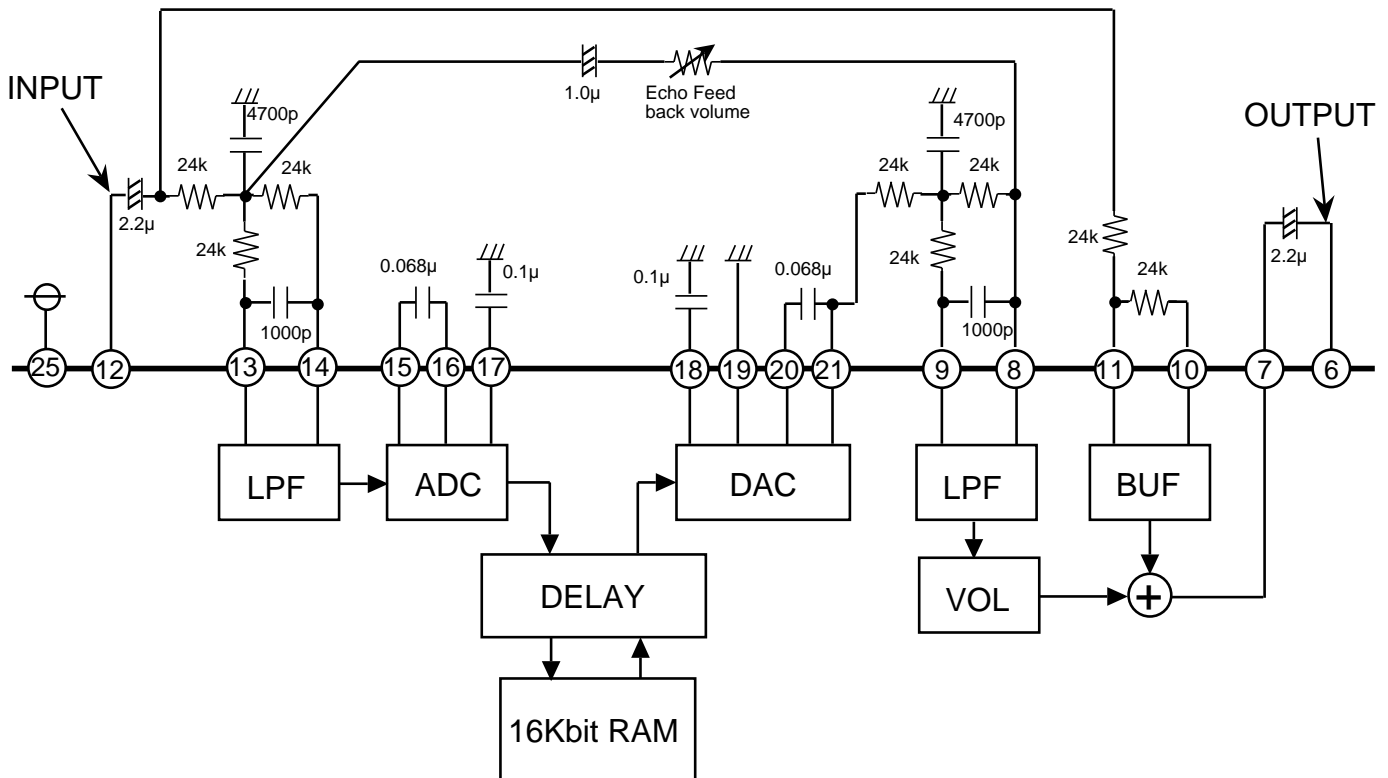

Delay time 100msec,130msec,150msec,200msec
Volume level +4~-6dB/2dB step and -10dB, - 8 level
 (same as key control volume)

PRELIMINARY

Notice ; This is not a final specification.
some parametric limits are subject to change.

MITSUBISHI SEMICONDUCTORS
(SOUND PROCDSOR ICs)

M65851FP



Phase Shifter Block

Following is the phase shifter block, which makes phase surround effect.

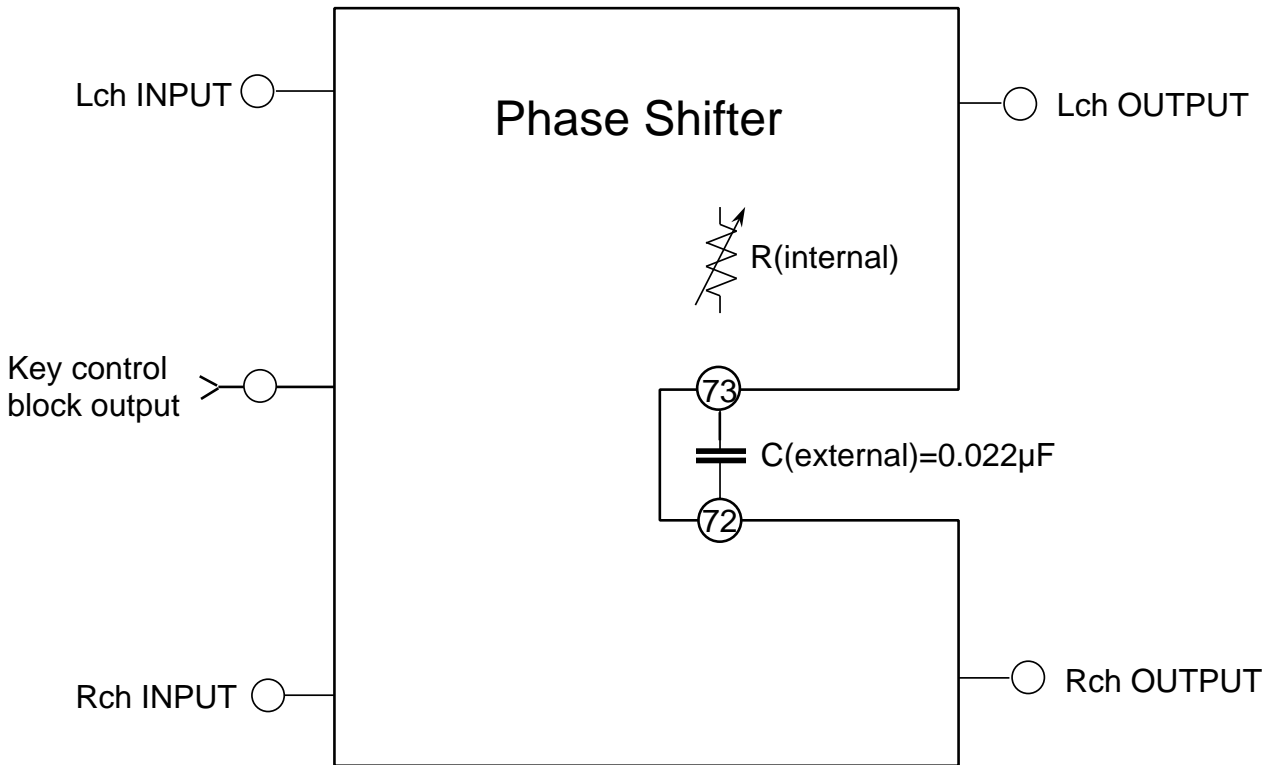

Switch conditions		Surround effect
Surround SW ON	R=13k	Max
	R=16k	Typ
	R=20k	Min
Surround SW OFF		Nothing

PRELIMINARY
 Notice ; This is not a final specification.
 some parametric limits are subject to change.

MITSUBISHI SEMICONDUCTORS
 (SOUND PROCDSOR ICs)

M65851FP



Equalizer Block

Following is the equalizer block, which can control the both gain bass and treble.

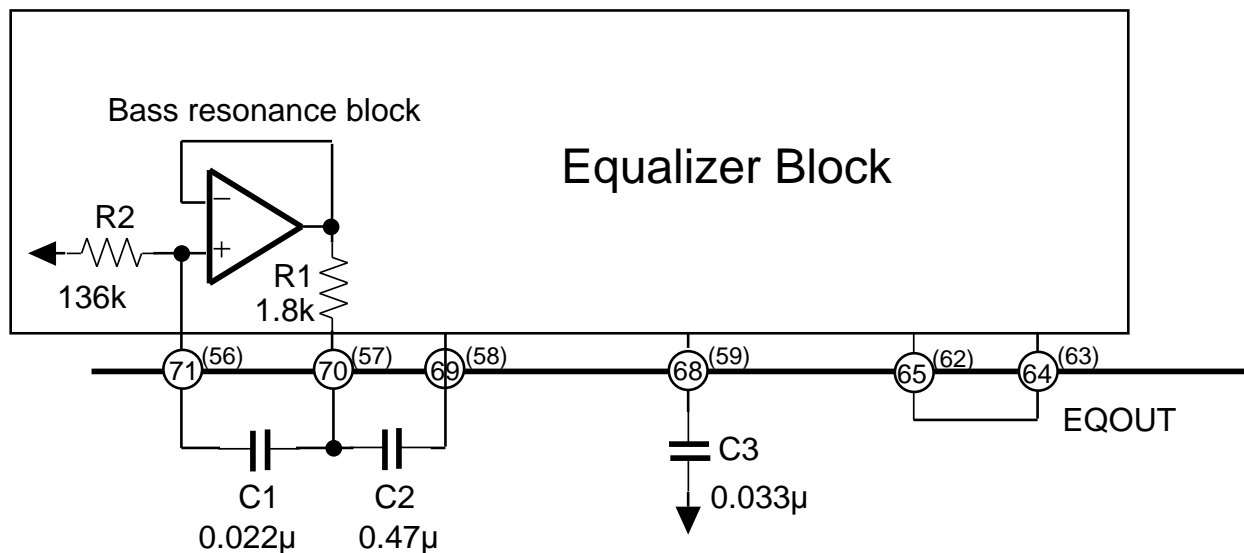

Bass block is resonance type which is used simulated inductor amplifier. Treble block is filter type. These can be set -12dB ~ +12dB/2dB step.

Following is a center frequency "fo" ,"Q" (bass resonance block).

$$f_o = 1 / (2 \sqrt{C_1 \cdot C_2 \cdot R_1 \cdot R_2}) \quad (\text{Hz})$$

$$Q = \sqrt{(C_1 \cdot R_2) / (C_2 \cdot R_1)}$$

PRELIMINARY
 Notice ; This is not a final specification.
 some parametric limits are subject to change.

MITSUBISHI SEMICONDUCTORS
 (SOUND PROCDSOR ICs)

M65851FP



Vocal Cut Block

The sound components of the same phase and same sound volume in the L and R channels are attenuated.
 This made also allows components with lower frequency than the vocal band to pass through the filter, to compensate insufficient low-frequency sound.

vocal cut block

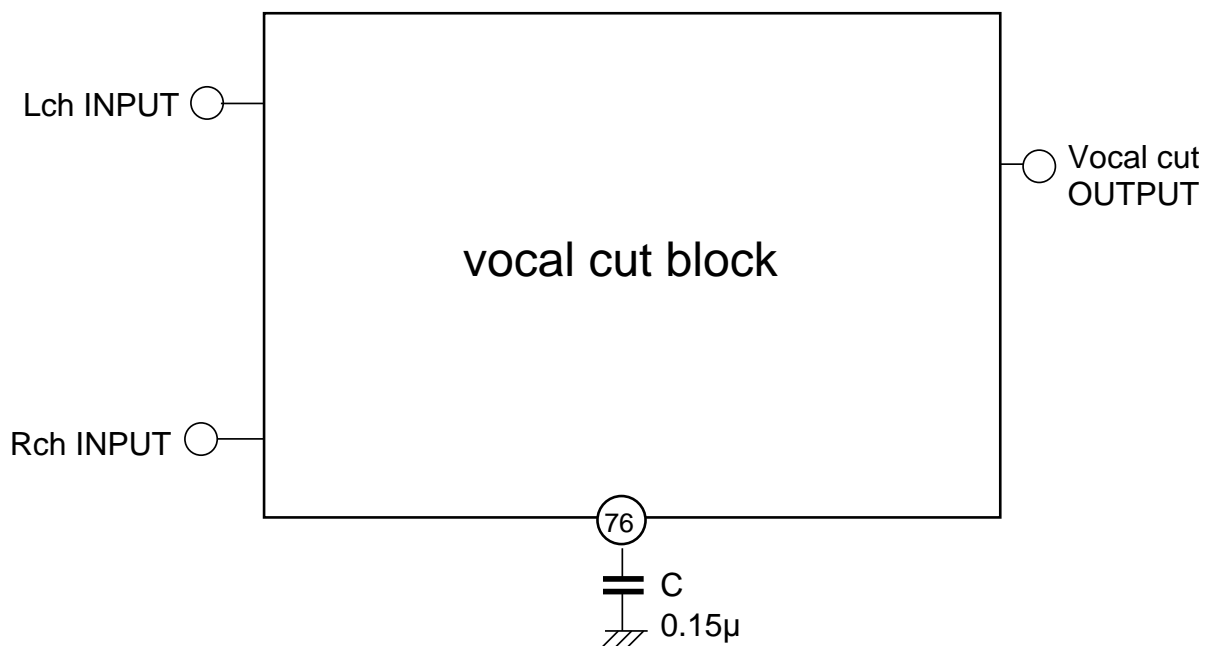

$$f_{vc} = \frac{1}{2 CR}$$

LPF is formed by the internal R (20k) and the external C, when
 Where C=0.15µ F , cut off frequency is 53Hz .

PRELIMINARY
Notice ; This is not a final specification.
some parametric limits are subject to change.

MITSUBISHI SEMICONDUCTORS
(SOUND PROCDSOR ICs)

M65851FP



Scoring Function

Scoring function judge the mic vocal input .

1.Scoring output form

Mic input is judged from 0 to 99 level.

2.Constitution

Scoring function is constituted following two ways.

Judgment conditions	Function	Ratio
①Compare the frequency	Compare the frequency reference voice and microphone voice	75%
②Vocal level judgment	Vocal level judgment (as vocal is bigger than reference level,judgment is good)	25%

PRELIMINARY

Notice ; This is not a final specification.
some parametric limits are subject to change.

MITSUBISHI SEMICONDUCTORS
(SOUND PROCSSOR ICs)

M65851FP



3.Music search

Music search is constituted following .

- ① Input signal reference level comparison
- ② Music detection
- ③ No music detection

① Input signal reference level comparison

Input signal reference level comparison is comstituted amplifier and level comarison.
When input signal is bigger than reference level,level comparison output the pulse
which added internal clock.

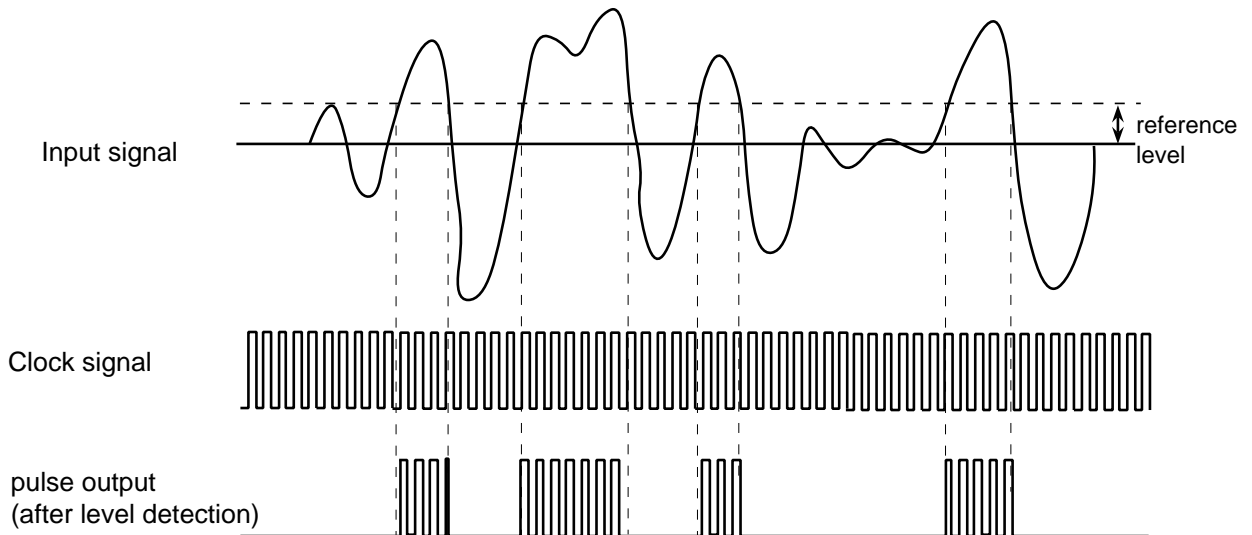

Then reference level can be changed ,thanks to the following internal R2 and external R1 which determine the amplifier gain .

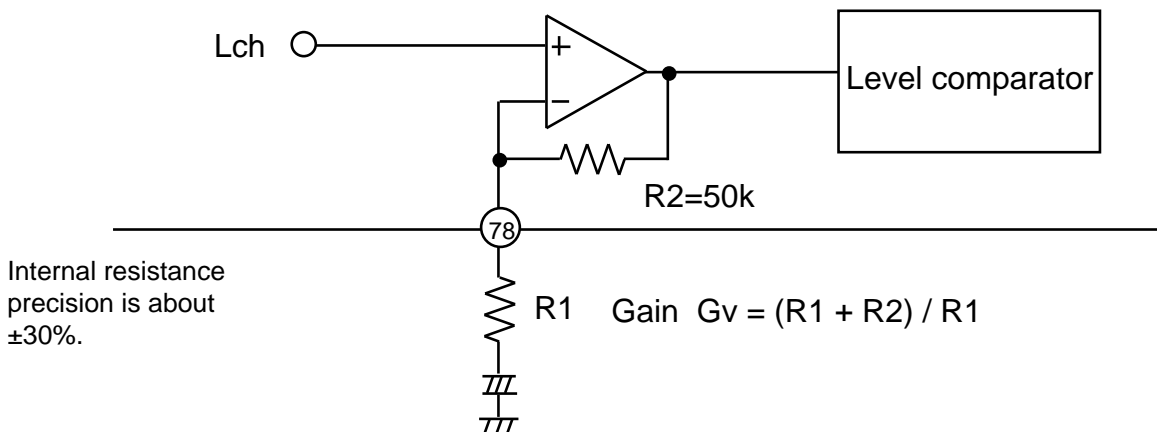

PRELIMINARY
Notice ; This is not a final specification.
some parametric limits are subject to change.

MITSUBISHI SEMICONDUCTORS
(SOUND PROC DSSOR ICs)

M65851FP



② Music detection

To search a music interval, it is necessary to judge if it is a music or not. This judgment is made by monitoring the 20 seconds and counting the pulse signal (after level detection). The pulse signal counts is bigger than fixed counts, it is judged as a music.

Pulse counter is reset whenever monitor 20 seconds or judged no music decision.

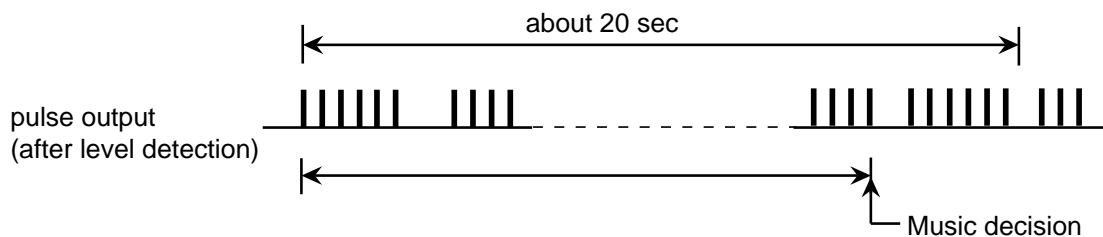

③ No music detection

After Music decision (②), no music is judged when no pulse in level detection at 3 seconds. But if there isn't no pulse when monitoring the 3 seconds, no music decision counter is reset.

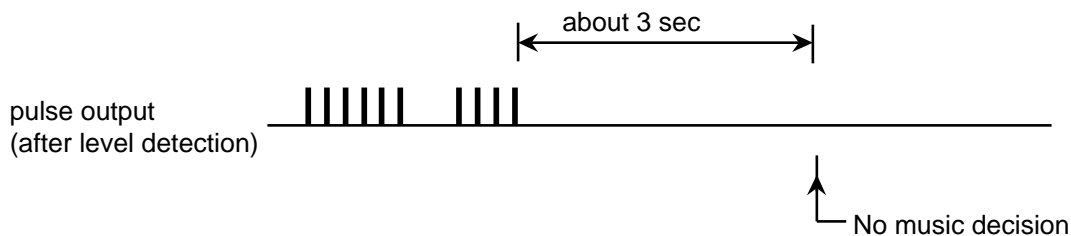

PRELIMINARY

Notice ; This is not a final specification.
some parametric limits are subject to change.

MITSUBISHI SEMICONDUCTORS
(SOUND PROCSSOR ICs)

M65851FP



4.Signal input circuit

Signal input circuit is constituted the following band pass filter, which cuts the input signal to vocal band width.

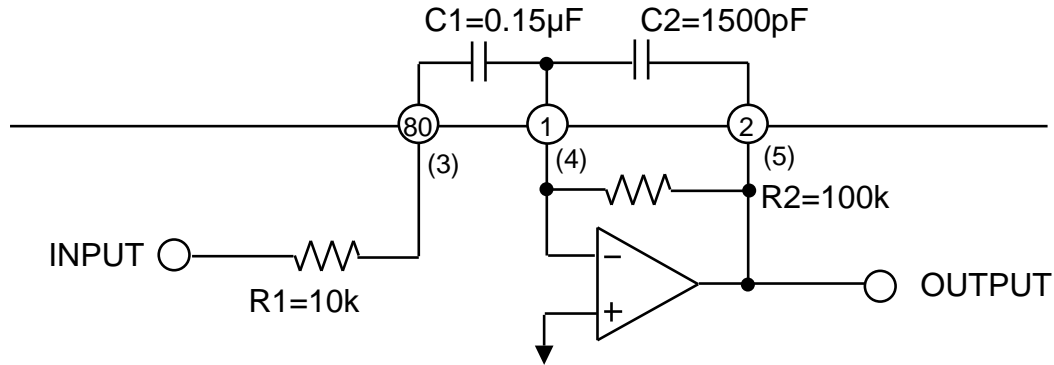

Low level cut off frequency f_{cl} and High level cut off frequency f_{ch} is

$$f_{cl} = 1/2 C1R1 = 106 \text{ Hz}$$

$$f_{ch} = 1/2 C2R2 = 1.1\text{kHz}$$

and , the gain of amplifier G_v is

$$G_v = R2/R1 = 20 \text{ dB.}$$

Same as the band pass filter is constituted microphone signal input.

Automatic Vocal Support

In case using the Karaoke system , when microphone input level is nothing , then audio source vocal appears and help the microphone songs.
(It can set only following conditions , audio source selector sets Lch monaural or vocal cut)

Microphone input level	Source selector mode		
On	Lch monaural	vocal cut	others
Off	(L+R)/2	(L+R)/2	same as microphone input

Changing time from microphone input level changed to source selector changed is following .

Attack time (Off→On)0 sec

Release time (On → Off) 1sec or 2 sec

PRELIMINARY

Notice ; This is not a final specification.
some parametric limits are subject to change.

MITSUBISHI SEMICONDUCTORS
(SOUND PROCDSOR ICs)

M65851FP



The timing of microphone input signal detection

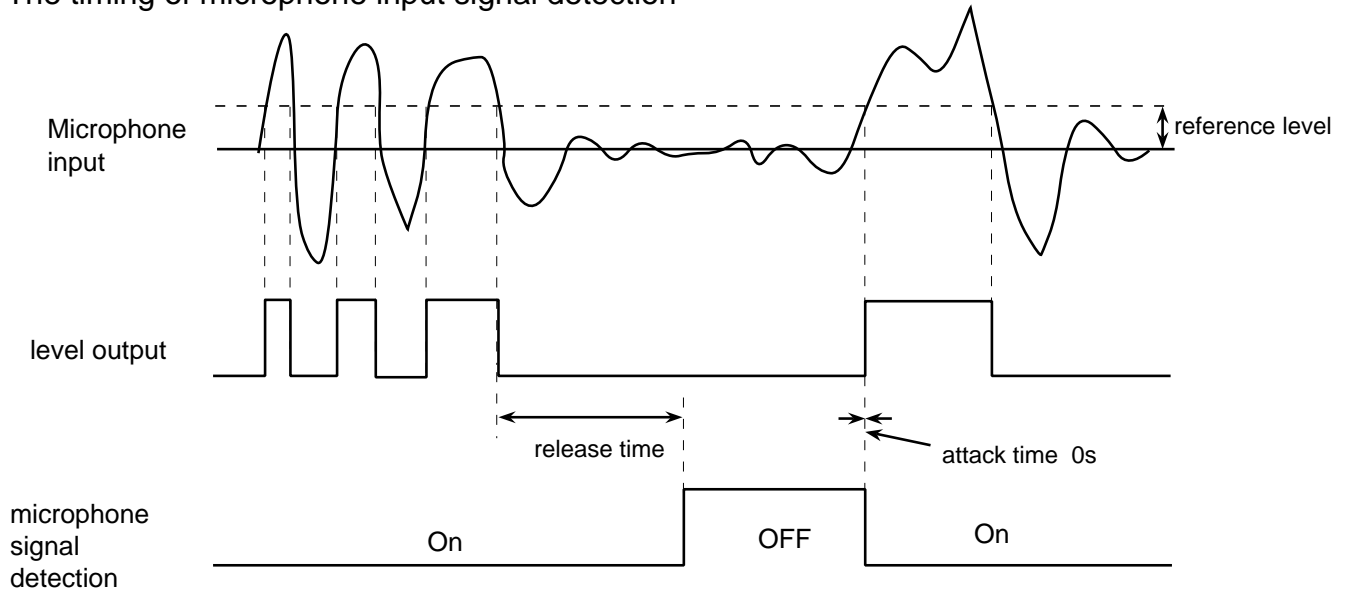

Following is the microphone input signal judgment block , which includes amplifier so reference level can regulate.

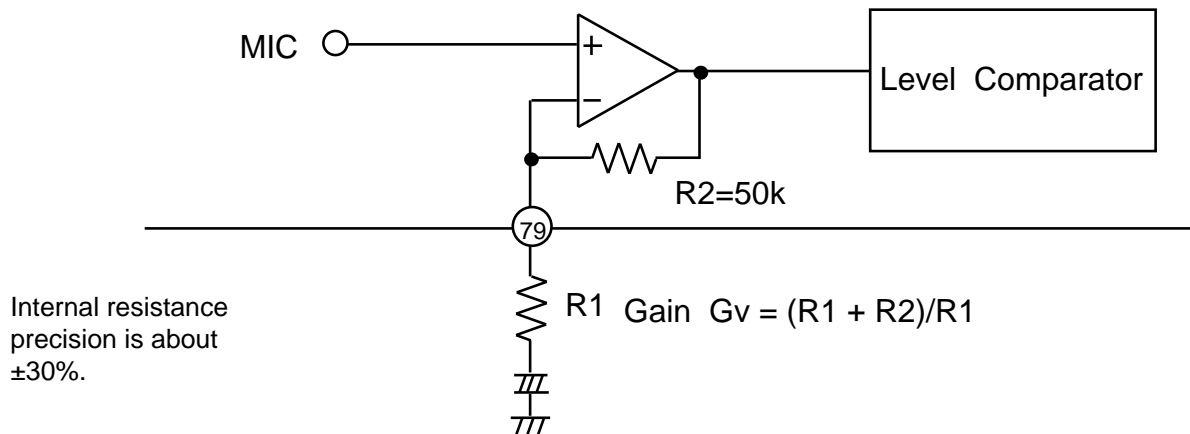

PRELIMINARY

Notice ; This is not a final specification.
some parametric limits are subject to change.

MITSUBISHI SEMICONDUCTORS
(SOUND PROCSSOR ICs)

M65851FP



Oscillation Circuit

This IC incorporates a current control type clock oscillator circuit in it, thus providing circuit configuration just by connecting a R for current control pin 29 (CLKCNT). Fully internal clock supply prevents occurrence of undesired radiation without affecting any external circuit.

The oscillator frequency fck is following.

$$fck = 8 \text{ MHz}$$

Reset

This IC is automatically reset when the power is turned on , and is automatically canceled nearly 120msec later.

Function		First set
Echo	Delay time	150msec
Key control		No changing
Phase shifter		OFF
Equalizer		OFF
Source selector		Stereo(Key control by pass)
Scoring function		OFF

PRELIMINARY

Notice ; This is not a final specification.
some parametric limits are subject to change.

MITSUBISHI SEMICONDUCTORS
(SOUND PROCDSOR ICs)

M65851FP



MCU Interface

1. Constitutions

MCU interface is constituted serial bass interface ,
so the selection, data input or output , is changed
by 36 pin input level .

③⑥ W/RSEL	Conditions
L	MCU → IC (Data input)
H	IC → MCU (Data output)

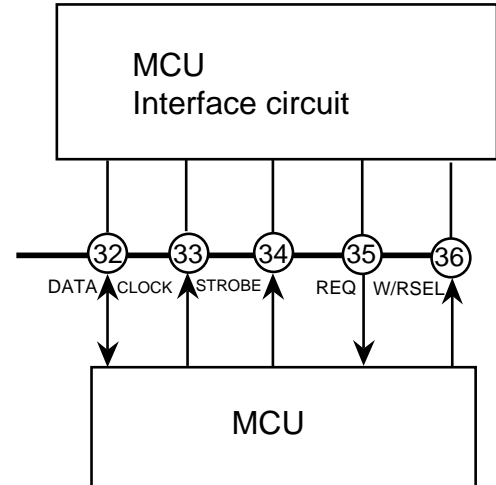

2. Data input

(1) Data input format

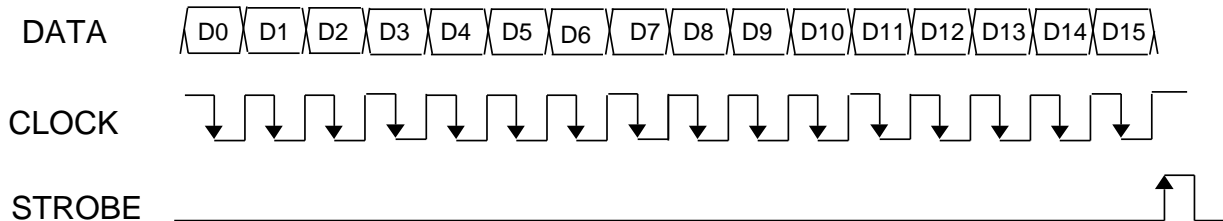

(2) Mode creations

D0~D1 select the following each block, and D2 ~ D13 create the particular setting.
D14,D15 are chip address, so this IC can use only when D14="L" and D15="H".

D0	D1	D2~D13	D14	D15
L	L	Echo/Surround mode	Chip addles L H	
L	H	Key control mode		
H	L	Equalizer/Phase sifter mode		
H	H	Line mixing/Others mode		

PRELIMINARY
 Notice ; This is not a final specification.
 some parametric limits are subject to change.

MITSUBISHI SEMICONDUCTORS
 (SOUND PROCDSOR ICs)

M65851FP



① Echo /Surround mode

D0	D1	D2	D3	D4	D5	D6	D7	D8	D9	D10	D11	D12	D13	D14	D15
L	L	Echo/ Surround	Echo delay time	Surround delay time			delay volume		Feed back volume			L	H		

Parameter	D2	D3	D4	D5	D6	D7	Function	
Echo/Surround Switch	L	-	-	-	-	-	Echo	On not key control set mode sets H level
	H	-	-	-	-	-	Surround	
Echo delay time	-	L	L	-	-	-	100msec	
	-	H	L	-	-	-	130msec	
	-	L	H	-	-	-	150msec	
	-	H	H	-	-	-	200msec	
Surround delay time	-	-	-	H	L	L	10msec	
	-	-	-	L	H	L	15msec	
	-	-	-	H	H	L	20msec	
	-	-	-	L	L	H	30msec	
	-	-	-	H	L	H	50msec	

PRELIMINARY

Notice ; This is not a final specification.
some parametric limits are subject to change.

MITSUBISHI SEMICONDUCTORS
(SOUND PROCDSOR ICs)

M65851FP



Parameter	D8	D9	D10	D11	D12	D13	Function
Delay volume	H	H	H	-	-	-	+6dB
	H	H	L	-	-	-	+3dB
	H	L	H	-	-	-	0dB
	H	L	L	-	-	-	-3dB
	L	H	H	-	-	-	-6dB
	L	H	L	-	-	-	-9dB
	L	L	H	-	-	-	-12dB
	L	L	L	-	-	-	-
Feed back volume	-	-	-	H	H	H	-2dB
	-	-	-	H	H	L	-3dB
	-	-	-	H	L	H	-4dB
	-	-	-	H	L	L	-5dB
	-	-	-	L	H	H	-6dB
	-	-	-	L	H	L	-8dB
	-	-	-	L	L	H	-10dB
	-	-	-	L	L	L	-

②Key control mode

D0	D1	D2	D3	D4	D5	D6	D7	D8	D9	D10	D11	D12	D13	D14	D15
L	H	Auto Reset	VSC/VMC	Key change level				Key control volume			Delay volume select	Delay signal mute	L	H	

PRELIMINARY
 Notice ; This is not a final specification.
 some parametric limits are subject to change.

MITSUBISHI SEMICONDUCTORS
 (SOUND PROCSSOR ICs)

M65851FP



Parameter	D2	D3	D4	D5	D6	D7	D8	Function
Automatic key control reset	L	-	-	-	-	-	-	automatic reset OFF
	H	-	-	-	-	-	-	automatic reset ON
Key control mode selector	-	L	-	-	-	-	-	VMC mode
	-	H	-	-	-	-	-	VSC mode
Key change level	-	-	H	H	L	L	L	+8
	-	-	H	L	H	H	H	+7
	-	-	H	L	H	H	L	+6
	-	-	H	L	H	L	H	+5
	-	-	H	L	H	L	L	+4
	-	-	H	L	L	H	H	+3
	-	-	H	L	L	H	L	+2
	-	-	H	L	L	L	H	+1
	-	-	L	L	L	L	L	0
	-	-	L	L	L	L	H	-1
	-	-	L	L	L	H	L	-2
	-	-	L	L	L	H	H	-3
	-	-	L	L	H	L	L	-4
	-	-	L	L	H	L	H	-5
	-	-	L	L	H	H	L	-6
	-	-	L	L	H	H	H	-7
-	-	L	H	L	L	L	-8	

PRELIMINARY
 Notice ; This is not a final specification.
 some parametric limits are subject to change.

MITSUBISHI SEMICONDUCTORS
 (SOUND PROCSSOR ICs)

M65851FP



Parameter	D9	D10	D11	Function
Key control volume set (when not key control mode, it use a echo volume)	H	H	H	+4dB
	H	H	L	+2dB
	H	L	H	0dB
	H	L	L	-2dB
	L	H	H	-4dB
	L	H	L	-6dB
	L	L	H	-10dB
	L	L	L	-

Parameter	D12	D13	Function
Delay volume selector	L	-	Using an echo volume
	H	-	Using a microphone volume
Delay signal mute	-	L	Mute OFF
	-	H	Mute ON

③Equalizer/Phase shifter mode

D0	D1	D2	D3	D4	D5	D6	D7	D8	D9	D10	D11	D12	D13	D14	D15
H	L	automatic vocal support		Phase shifter		Equalizer treble			Equalizer bass			L	H		

PRELIMINARY

Notice ; This is not a final specification.
some parametric limits are subject to change.

MITSUBISHI SEMICONDUCTORS
(SOUND PROCSSOR ICs)

M65851FP



Parameter	D2	D3	D4	D5	Function
Automatic vocal support (It can use only echo mode)	L	-	-	-	OFF
	H	-	-	-	ON
	-	L	-	-	Release time 1sec
	-	H	-	-	Release time 2sec
Phase shifter surround mode	-	-	L	L	OFF
	-	-	H	L	Surround effect Minimum
	-	-	L	H	Surround effect Typical
	-	-	H	H	Surround effect Maximum

Equalizer treble mode

Equalizer bass mode

D6	D7	D8	D9	Volume(dB)
H	H	H	L	+12
H	H	L	H	+10
H	H	L	L	+8
H	L	H	H	+6
H	L	H	L	+4
H	L	L	H	+2
L	L	L	L	0
L	L	L	H	-2
L	L	H	L	-4
L	L	H	H	-6
L	H	L	L	-8
L	H	L	H	-10
L	H	H	L	-12

D10	D11	D12	D13	Volume(dB)
H	H	H	L	+12
H	H	L	H	+10
H	H	L	L	+8
H	L	H	H	+6
H	L	H	L	+4
H	L	L	H	+2
L	L	L	L	0
L	L	L	H	-2
L	L	H	L	-4
L	L	H	H	-6
L	H	L	L	-8
L	H	L	H	-10
L	H	H	L	-12

PRELIMINARY

Notice ; This is not a final specification.
some parametric limits are subject to change.

MITSUBISHI SEMICONDUCTORS
(SOUND PROCDSOR ICs)

M65851FP



④Line mixing/Others mode

D0	D1	D2	D3	D4	D5	D6	D7	D8	D9	D10	D11	D12	D13	D14	D15
H	H	Source selector		Key control by pass	Key control mixing	Delay mixing		Scoring function			Voice key control	L	H		

Parameter	D2	D3	D4	D5	D6	Function	
Source selector	L	L	L	-	-	Stereo	Delay block input L-R
			H	-	-		Delay block input (L+R)/2
	L	H	-	-	-	Lch monaural	
	H	L	-	-	-	Rch monaural	
	H	H	-	-	-	Vocal cut	
Key control by pass	-	-	-	L	-	By pass OFF(Though the key control circuit)	
	-	-	-	H	-	By pass ON(By pass the key control circuit)	
Key control mixing ON/OFF Selector	-	-	-	-	L	Mixing OFF(SSSW10="2")	
	-	-	-	-	H	Mixing ON(SSSW10="1")	

Relationships source selector and key control by pass mode

D2	D3	Key control mixing by pass ON	Key control mixing by pass OFF
L	L	Stereo	(L+R)/2
L	H	Lch monaural	Lch monaural
H	L	Rch monaural	Rch monaural
H	H	Vocal cut	Vocal cut

PRELIMINARY
 Notice ; This is not a final specification.
 some parametric limits are subject to change.

MITSUBISHI SEMICONDUCTORS
 (SOUND PROCSSOR ICs)

M65851FP



Parameter	D7	D8	D9	D10	D11	D12	D13	Function	
Delay signal mixing ON/OFF Selector	L	-	-	-	-	-	-	Mixing OFF	
	H	L	-	-	-	-	-	Mixing ON(L,R same phase)	
	H	H	-	-	-	-	-	Mixing ON(L,R reverse phase)	
Scoring function	-	-	L	-	-	-	-	Scoring function OFF	
	-	-	H	-	-	-	-	Scoring function ON	
	-	-	-	L	-	-	-	Score output after no music decision	
	-	-	-	H	-	-	-	Score can output always timing	
	-	-	-	-	L	-	-	Internal music detection decides the scoring start/stop timing *	
	-	-	-	-	H	L	-	MCU data decides the scoring start/stop timing *	Scoring stop
	-	-	-	-	H	H	-		Scoring start
Voice key control	-	-	-	-	-	-	L	OFF	
	-	-	-	-	-	-	H	ON	

* Scoring function start /stop mode

①Decide the internal music detection (D11="L")

②Decide the MCU data(D11="H")

When D12 is "L" level scoring is stopping ,and change "H" level, scoring is start until D12 changes "L"level.

PRELIMINARY

Notice ; This is not a final specification.
some parametric limits are subject to change.

MITSUBISHI SEMICONDUCTORS
(SOUND PROCSSOR ICs)

M65851FP



3.Data output(Score result output)

(1)Internal music detection decides the scoring output timing

When Karaoke song is over and then music detection judgment the no music detection, scoring is over and output the "H" pulse to REQ.

After REQ is "H" level and then W/RSEL changes from "L" to "H",this IC changes a output mode and it can output the score result.

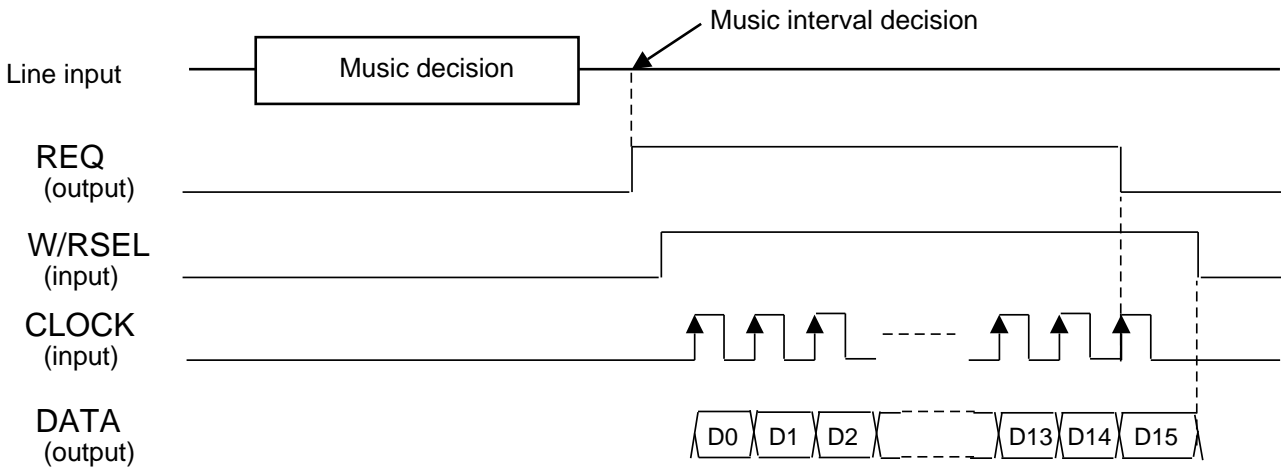

(2)MCU data decides the scoring result data output timing

W/RSEL changes from "L"to "H",so this IC changes output mode ,and then score result data can output the same period of the clock .

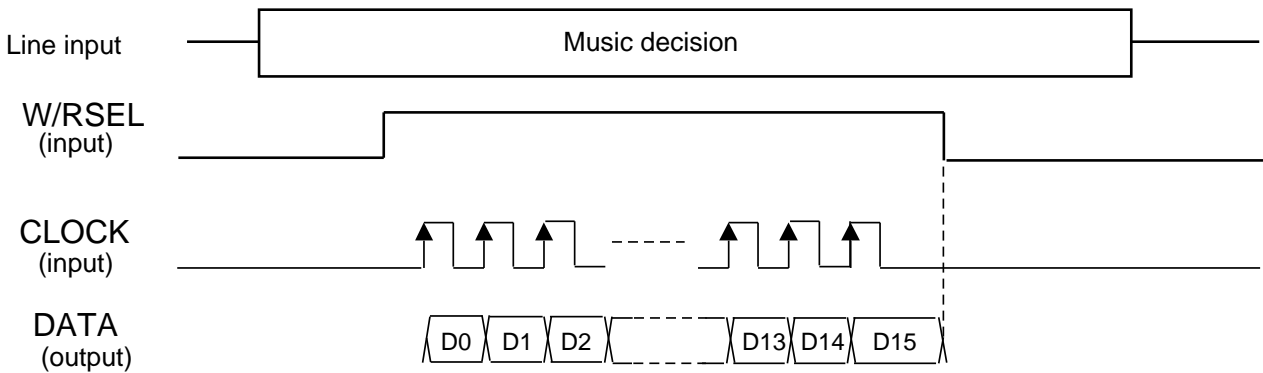

(3)Data format

D0	D1	D2	D3	D4	D5	D6	D7	D8	D9	D10	D11	D12	D13	D14	D15	
								Music interval decision	(MSB)	Score result output (binary output)						(LSB)

D8 : Music interval decision music decision="H", music interval decision="L"

D9~D15 : Score result output D9 D10 D11 D12 D13 D14 D15

an example@78 points H L L H H H L

PRELIMINARY

Notice ; This is not a final specification.
some parametric limits are subject to change.

MITSUBISHI SEMICONDUCTORS
(SOUND PROCSSOR ICs)

M65851FP



Caution

1. Input/output signal level

When using phase shifter, echo mixing and equalizer ,this IC is limited the following functions. So, please determine the level of the each functions.

Input base level	Equalizer gain mode	Head room	S/N
150mVrms	0dB	10.6dB	78.5dB
100mVrms	+6dB	8.1dB	75dB
100mVrms	+12dB	2.1dB	75dB
50mVrms	+12dB	8.1dB	69dB

2. Improvement of head room

As stated above, equalizer gain level is bigger, head room becomes also narrow. So It can be Improvement that latest opeamp which using equalizer use external opeamp.

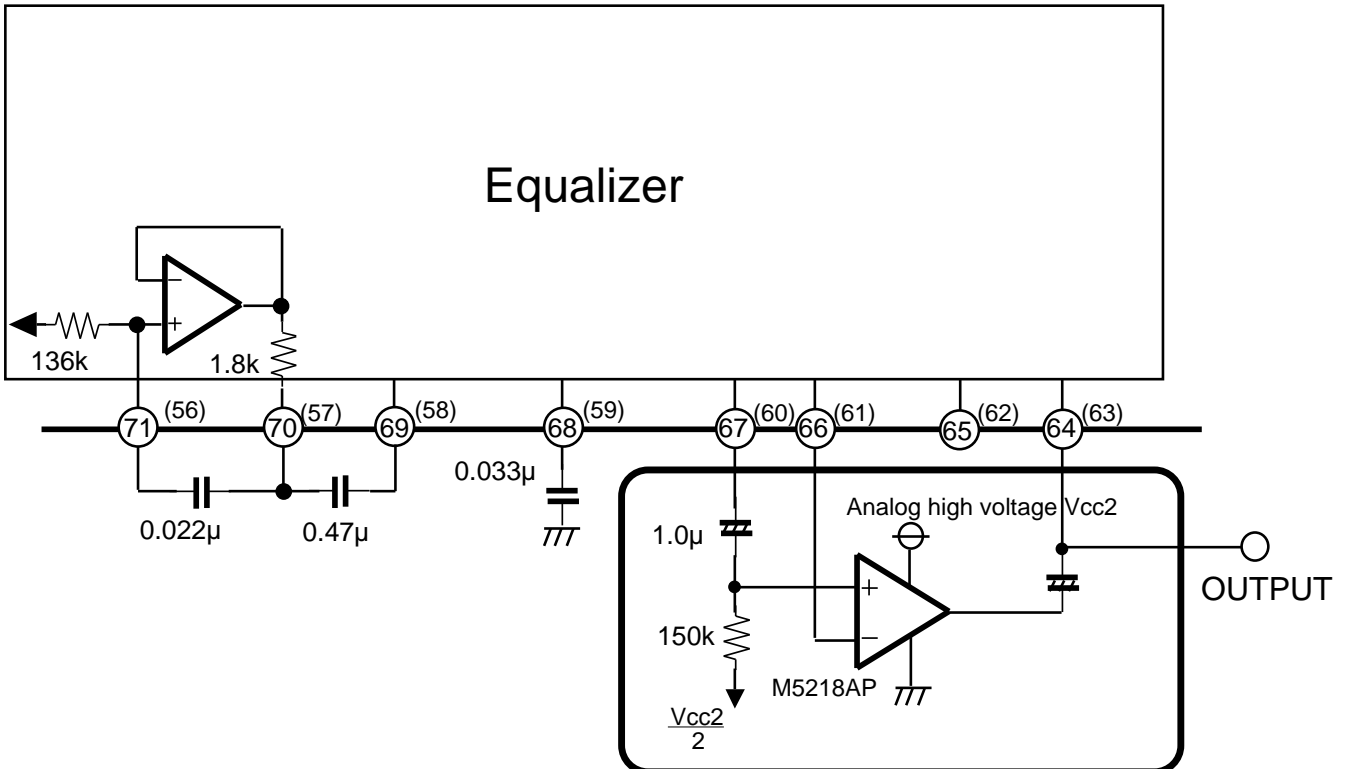

PRELIMINARY
 Notice ; This is not a final specification.
 some parametric limits are subject to change.

mitsubishi semiconductors
 (SOUND PROCSSOR ICs)

M65851FP



Following the relations supply voltage, input signal level ,head room and S/N.
 (external opamp ;M5218AP)

Vcc2	Input level	Equalizer gain level	Head room	S/N
9V	150mVrms	+6dB	8.1dB	78.5dB
		+12dB	2.1dB	78.5dB
	100mVrms	+6dB	11.6dB	75dB
		+12dB	5.6dB	75dB
15V	150mVrms	+6dB	10.6dB <small>(effect M65851FP)</small>	78.5dB
		+12dB	8.1dB	78.5dB
	100mVrms	+6dB	14.1dB <small>(effect M65851FP)</small>	75dB
		+12dB	11.6dB	75dB
20V	150mVrms	+12dB	10.6dB <small>(effect M65851FP)</small>	78.5dB
	100mVrms	+12dB	14.1dB <small>(effect M65851FP)</small>	75dB

PRELIMINARY

Notice ; This is not a final specification.
Some parametric limits are subject to change.

MITSUBISHI SEMICONDUCTORS
(SOUND PROCSSOR ICs)

M65851FP



APPLICATION EXAMPLE

