

Features

- Transformerless 2-4 wire conversion
- Line state detection outputs
- - forward current
- - reverse current
- - ring ground
- - tip ground
- - ringing voltage
- Programmable audio transmit and receive gain
- Loop start or ground start termination
- Selectable 600Ω or AT&T compromise balance network
- -1 version: 20Hz Ringing Voltage
- -2 version: 50Hz Ringing Voltage

Applications

- PBX
- Channel bank
- Intercom
- Key System

ISSUE 4

April 1995

Ordering Information

MH88631-1 40 Pin SIL Package
 MH88631-2 40 Pin SIL Package

0°C to 70°C

Description

The Mitel MH88631-1, 2 Central Office Trunk Interface circuit provides a complete audio and signalling link between audio switching equipment and a central office. The loop seize circuitry is controlled by an external input to provide either a loop start or ground start termination. The device is fabricated using thick film ceramic technology to achieve high density circuit design.

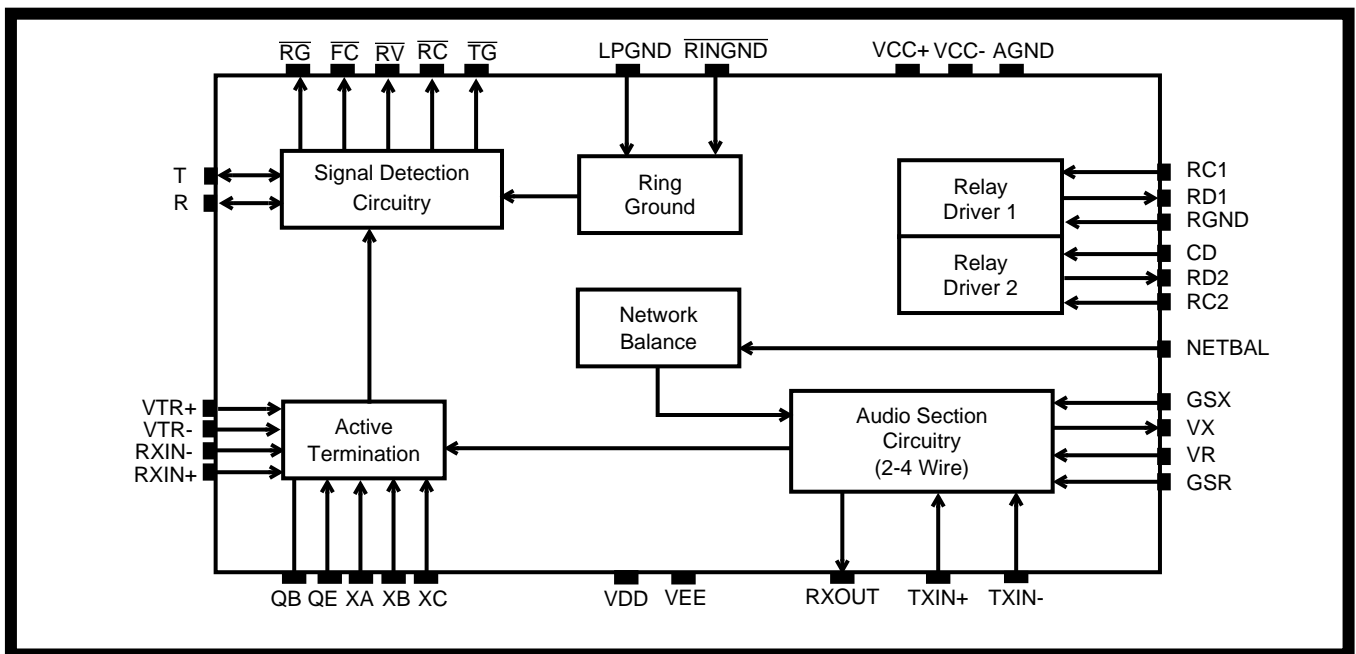

Figure 1 - Functional Block Diagram

Notes:



**For more information about all Zarlink products
visit our Web Site at
www.zarlink.com**

Information relating to products and services furnished herein by Zarlink Semiconductor Inc. trading as Zarlink Semiconductor or its subsidiaries (collectively "Zarlink") is believed to be reliable. However, Zarlink assumes no liability for errors that may appear in this publication, or for liability otherwise arising from the application or use of any such information, product or service or for any infringement of patents or other intellectual property rights owned by third parties which may result from such application or use. Neither the supply of such information or purchase of product or service conveys any license, either express or implied, under patents or other intellectual property rights owned by Zarlink or licensed from third parties by Zarlink, whatsoever. Purchasers of products are also hereby notified that the use of product in certain ways or in combination with Zarlink, or non-Zarlink furnished goods or services may infringe patents or other intellectual property rights owned by Zarlink.

This publication is issued to provide information only and (unless agreed by Zarlink in writing) may not be used, applied or reproduced for any purpose nor form part of any order or contract nor to be regarded as a representation relating to the products or services concerned. The products, their specifications, services and other information appearing in this publication are subject to change by Zarlink without notice. No warranty or guarantee express or implied is made regarding the capability, performance or suitability of any product or service. Information concerning possible methods of use is provided as a guide only and does not constitute any guarantee that such methods of use will be satisfactory in a specific piece of equipment. It is the user's responsibility to fully determine the performance and suitability of any equipment using such information and to ensure that any publication or data used is up to date and has not been superseded. Manufacturing does not necessarily include testing of all functions or parameters. These products are not suitable for use in any medical products whose failure to perform may result in significant injury or death to the user. All products and materials are sold and services provided subject to Zarlink's conditions of sale which are available on request.

Purchase of Zarlink's I²C components conveys a licence under the Philips I²C Patent rights to use these components in an I²C System, provided that the system conforms to the I²C Standard Specification as defined by Philips.

Zarlink and the Zarlink Semiconductor logo are trademarks of Zarlink Semiconductor Inc.

Copyright 2002, Zarlink Semiconductor Inc. All Rights Reserved.

TECHNICAL DOCUMENTATION - NOT FOR RESALE
