

High Voltage Fast-Switching NPN Power Transistor

Features

- Very High Switching Speed (Typical 40ns@8.0A)
- Minimum Lot-to-Lot hFE Variation
- Low VCE(sat) (Typical 320mV@8.0A/1.6A)
- Wide Reverse Bias S.O.A

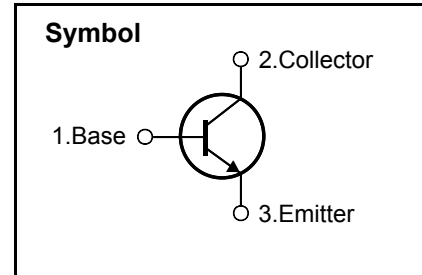

General Description

This device is designed for high voltage, high speed switching characteristic required such as switching mode power supply.

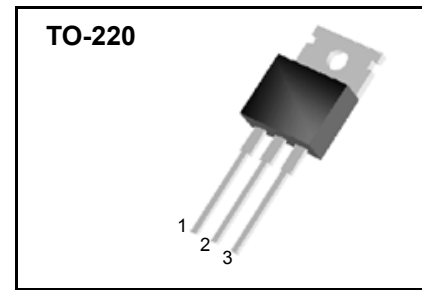

Absolute Maximum Ratings

Symbol	Parameter	Value	Units
V _{CES}	Collector-Emitter Voltage (V _{BE} = 0)	700	V
V _{CEO}	Collector-Emitter Voltage (I _B = 0)	400	V
V _{EBO}	Emitter-Base Voltage (I _C = 0)	9.0	V
I _C	Collector Current	12	A
I _{CM}	Collector Peak Current (t _p < 10 ms)	25	A
I _B	Base Current	6.0	A
I _{BM}	Base Peak Current (t _p < 10 ms)	12	A
P _C	Total Dissipation at T _C = 25 °C	100	W
T _{STG}	Storage Temperature	- 65 ~ 150	°C
T _J	Max. Operating Junction Temperature	150	°C

Thermal Characteristics

Symbol	Parameter	Value	Units
R _{θJC}	Thermal Resistance, Junction-to-Case	1.25	°C/W
R _{θJA}	Thermal Resistance, Junction-to-Ambient	40	°C/W

SBP13009

Electrical Characteristics ($T_C = 25\text{ }^\circ\text{C}$ unless otherwise noted)

Symbol	Parameter	Condition	Min	Typ	Max	Units
I_{CEV}	Collector Cut-off Current ($V_{BE} = -1.5V$)	$V_{CE} = 700V$ $V_{CE} = 700V$ $T_C = 100\text{ }^\circ\text{C}$	-	-	1.0 5.0	mA
$V_{CEO(sus)}$	Collector-Emitter Sustaining Voltage ($I_B = 0$)	$I_C = 10\text{ mA}$	400	-	-	V
$V_{CE(sat)}$	Collector-Emitter Saturation Voltage	$I_C = 5.0A$ $I_C = 8.0A$ $I_C = 12A$ $I_C = 8.0A$ $I_B = 1.0A$ $I_B = 1.6A$ $I_B = 3.0A$ $I_B = 1.6A$ $T_C = 100\text{ }^\circ\text{C}$	-	-	0.5 1.0 1.5 2.0	V
$V_{BE(sat)}$	Base-Emitter Saturation Voltage	$I_C = 5.0A$ $I_C = 8.0A$ $I_C = 8.0A$ $I_B = 1.0A$ $I_B = 1.6A$ $I_B = 1.6A$ $T_C = 100\text{ }^\circ\text{C}$	-	-	1.2 1.6 1.5	V
h_{FE}	DC Current Gain	$I_C = 5.0A$ $I_C = 8.0A$ $V_{CE} = 5V$ $V_{CE} = 5V$	10 6	-	30 30	
t_s t_f	Resistive Load Storage Time Fall Time	$I_C = 8.0A$ $I_{B1} = 1.6A$ $T_P = 25\mu s$ $V_{CC} = 125V$ $I_{B2} = -1.6A$	-	1.5 0.16	3.0 0.4	μs
t_s t_f	Inductive Load Storage Time Fall Time	$V_{CC} = 15V$ $I_{B1} = 1.6A$ $L_C = 0.2mH$ $I_C = 8.0A$ $V_{BE(off)} = 5V$ $V_{clamp} = 300V$	-	0.6 0.04	2.0 0.1	μs
t_s t_f	Inductive Load Storage Time Fall Time	$V_{CC} = 15V$ $I_{B1} = 1.6A$ $L_C = 0.2mH$ $I_C = 8.0A$ $V_{BE(off)} = 5V$ $V_{clamp} = 300V$ $T_C = 100\text{ }^\circ\text{C}$	-	0.8 0.05	2.5 0.15	μs

※ Notes :

Pulse Test : Pulse width $\leq 300\mu s$, Duty cycle $\leq 2\%$



Fig 1. Static Characteristics

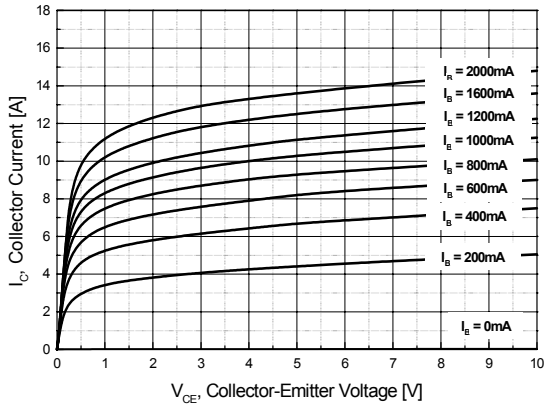

Fig 2. DC Current Gain

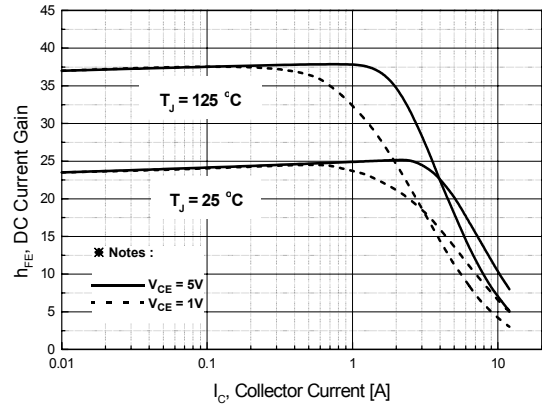

Fig 3. Collector-Emitter Saturation Voltage

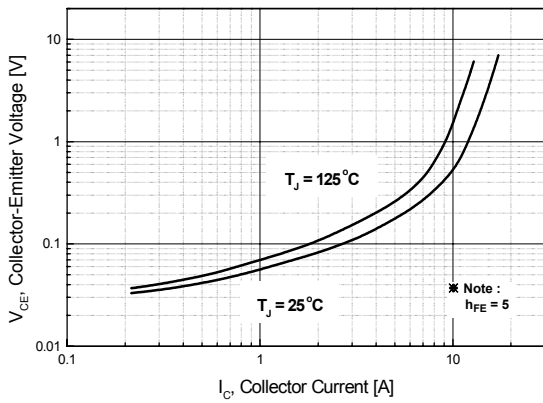

Fig 4. Base-Emitter Saturation Voltage

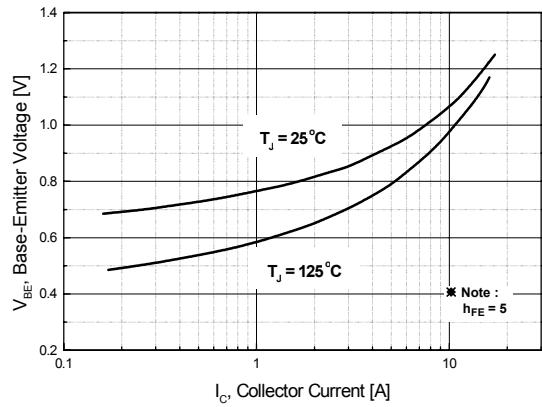

Fig 5. Resistive Load Fall Time

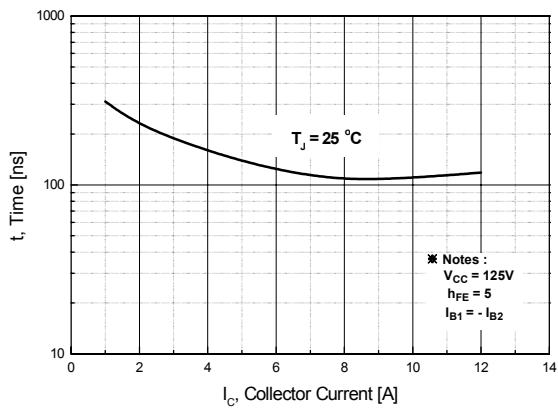
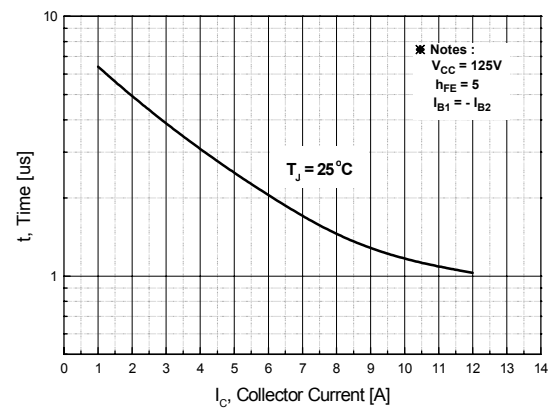

Fig 6. Resistive Load Storage Time



SBP13009

Fig 7. Safe Operation Areas

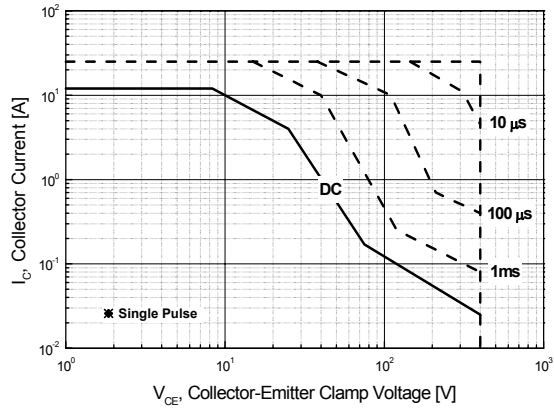

Fig 8. Reverse Biased Safe Operation Areas

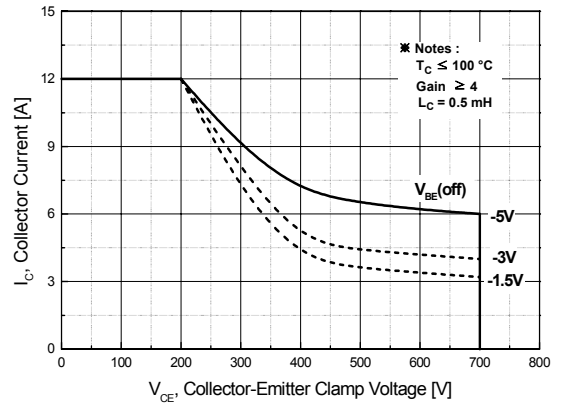
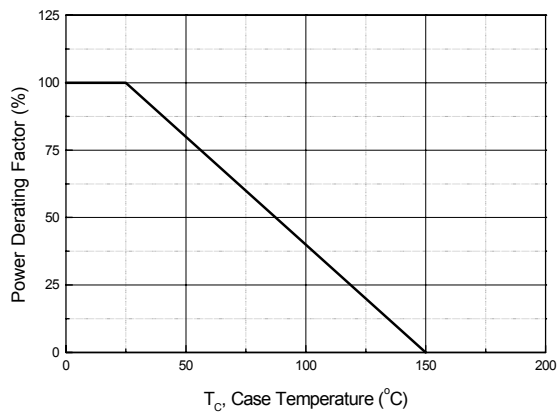
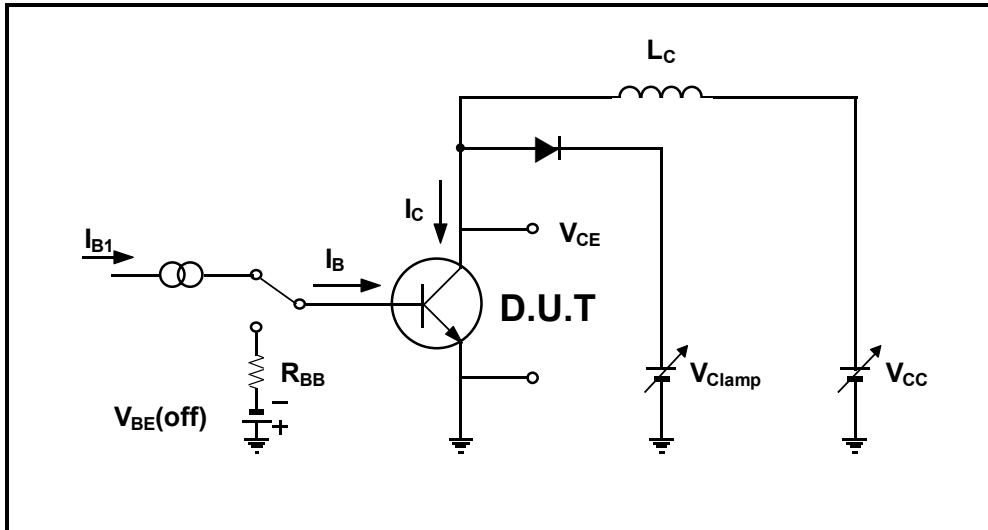

Fig 9. Power Derating Curve



Inductive Load Switching & RBSOA Test Circuit



Resistive Load Switching Test Circuit

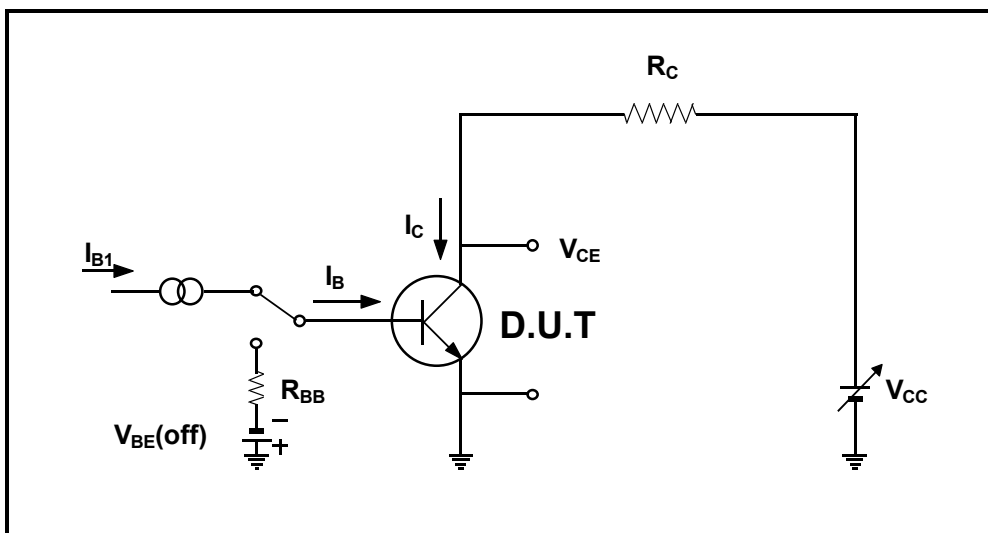

SBP13009

TO-220 Package Dimension

Dim.	mm			Inch		
	Min.	Typ.	Max.	Min.	Typ.	Max.
A	9.7		10.1	0.382		0.398
B	6.3		6.7	0.248		0.264
C	9.0		9.47	0.354		0.373
D	12.8		13.3	0.504		0.524
E	1.2		1.4	0.047		0.055
F		1.7			0.067	
G		2.5			0.098	
H	3.0		3.4	0.118		0.134
I	1.25		1.4	0.049		0.055
J	2.4		2.7	0.094		0.106
K	5.0		5.15	0.197		0.203
L	2.2		2.6	0.087		0.102
M	1.42		1.62	0.056		0.064
N	0.45		0.6	0.018		0.024
O	0.7		0.9	0.027		0.035
ϕ		3.6			0.142	

