

# 3.3V Software-Selectable Multiprotocol Transceiver

April 2002

## FEATURES

- Software-Selectable Transceiver Supports: RS232, RS449, EIA530, EIA530-A, V.35, V.36, X.21
- Operates from Single 3.3V Supply with LTC2846
- Complete DTE or DCE Port with LTC2846

## APPLICATIONS

- Data Networking
- CSU and DSU
- Data Routers

## DESCRIPTION

The LTC<sup>®</sup>2844 is a 4-driver/4-receiver multiprotocol transceiver. The LTC2844 and LTC2846 form the core of a complete software-selectable DTE or DCE interface port that supports the RS232, RS449, EIA530, EIA530-A, V.35, V.36 or X.21 protocols.

The LTC2844 operates from a 3.3V supply and supplies provided by the LTC2846. The part is available in a 28-lead SSOP surface mount package.

*LTC*, LTC and LT are registered trademarks of Linear Technology Corporation.

## TYPICAL APPLICATION

DTE or DCE Multiprotocol Serial Interface with DB-25 Connector

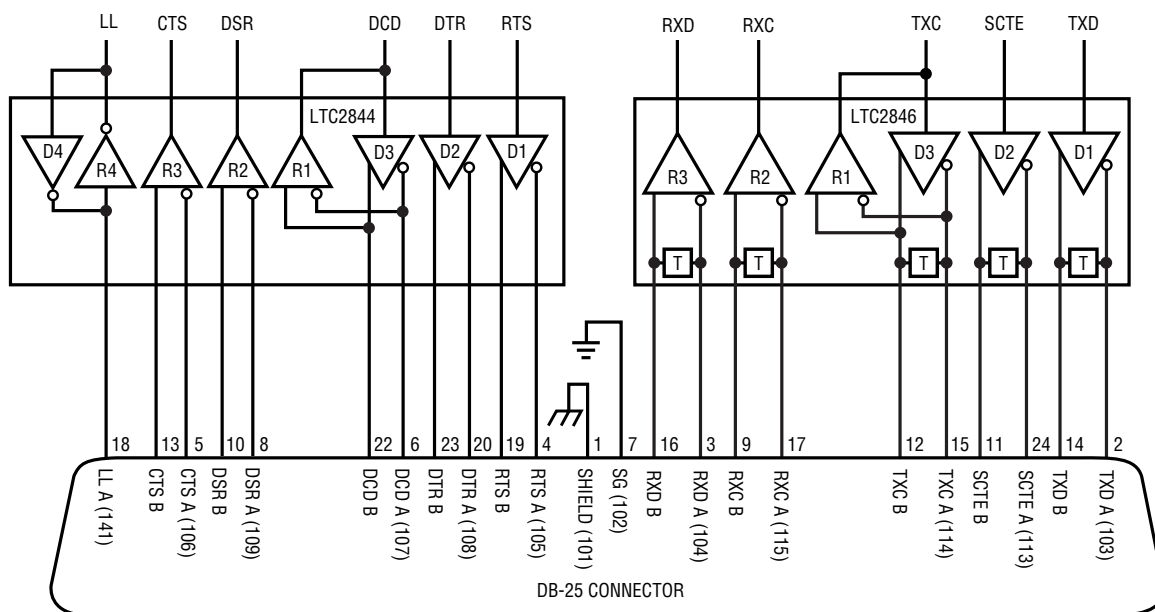

2844 TA01

## ABSOLUTE MAXIMUM RATINGS

(Note 1)

### Supply Voltage

$V_{CC}$ .....	-0.3V to 6.5V
$V_{IN}$ .....	-0.3V to 6.5V
$V_{EE}$ .....	-10V to 0.3V
$V_{DD}$ .....	-0.3V to 10V

### Input Voltage

Transmitters .....	-0.3V to ( $V_{CC} + 0.3V$ )
Receivers .....	-18V to 18V
Logic Pins .....	-0.3V to ( $V_{CC} + 0.3V$ )

### Output Voltage

Transmitters .....	( $V_{EE} - 0.3V$ ) to ( $V_{DD} + 0.3V$ )
Receivers .....	-0.3V to ( $V_{IN} + 0.3V$ )

### Short-Circuit Duration

Transmitter Output .....	Indefinite
Receiver Output .....	Indefinite
$V_{EE}$ .....	30 sec

### Operating Temperature Range

LTC2844CG .....	0°C to 70°C
LTC2844IG .....	-40°C to 85°C

### Storage Temperature Range

Lead Temperature (Soldering, 10 sec)..... 300°C

## PACKAGE/ORDER INFORMATION

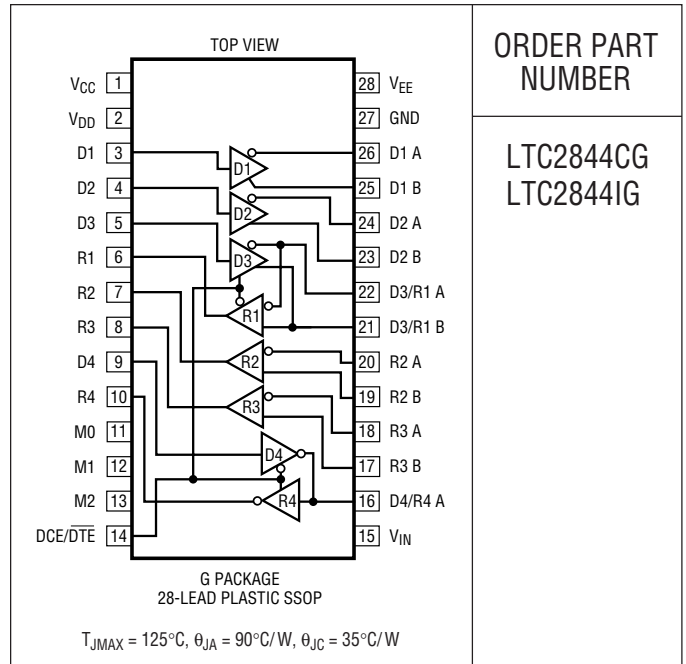

ORDER PART NUMBER

LTC2844CG  
LTC2844IG

Consult LTC Marketing for parts specified with wider operating temperature ranges.

## ELECTRICAL CHARACTERISTICS

The ● denotes specifications which apply over the full operating temperature range, otherwise specifications are at  $T_A = 25^\circ\text{C}$ .  $V_{CC} = 5V$ ,  $V_{IN} = 3.3V$ ,  $V_{DD} = 8V$ ,  $V_{EE} = -7V$  for V.28,  $-5.5V$  for V.10, V.11 (Notes 2, 3)

SYMBOL	PARAMETER	CONDITIONS	MIN	TYP	MAX	UNITS
<b>Supplies</b>						
$I_{CC}$	$V_{CC}$ Supply Current (DCE Mode, All Digital Pins = GND or $V_{IN}$ )	RS530, RS530-A, X.21 Modes, No Load	●	2.7		mA
		RS530, RS530-A, X.21 Modes, Full Load	●	95	120	mA
		V.28 Mode, No Load	●	1	2	mA
		V.28 Mode, Full Load	●	1	2	mA
		No-Cable Mode	●	600	1200	$\mu\text{A}$
$I_{EE}$	$V_{EE}$ Supply Current (DCE Mode Unless Otherwise Noted, All Digital Pins = GND or $V_{IN}$ )	RS530, RS530-A, X.21 Modes, No Load		1.6		mA
		RS530, X.21 Modes, Full Load (DTE Mode)		14		mA
		RS530-A, Full Load (DTE Mode)		25		mA
		V.28 Mode, No Load		1		mA
		V.28 Mode, Full Load		7.5		mA
No-Cable Mode		10		$\mu\text{A}$		
$I_{DD}$	$V_{DD}$ Supply Current (DCE Mode, All Digital Pins = GND or $V_{IN}$ )	RS530, RS530-A, X.21 Modes, No Load		0.2		mA
		RS530, RS530-A, X.21 Modes, Full Load		0.2		mA
		V.28 Mode, No Load		1		mA
		V.28 Mode, Full Load		8		mA
		No-Cable Mode		10		$\mu\text{A}$
$I_{VIN}$	$V_{IN}$ Supply Current (DCE Mode, All Digital Pins = GND or $V_{IN}$ )	All Modes Except No-Cable Mode		490		$\mu\text{A}$

**ELECTRICAL CHARACTERISTICS** The ● denotes specifications which apply over the full operating temperature range, otherwise specifications are at  $T_A = 25^\circ\text{C}$ .  $V_{CC} = 5\text{V}$ ,  $V_{IN} = 3.3\text{V}$ ,  $V_{DD} = 8\text{V}$ ,  $V_{EE} = -7\text{V}$  for V.28,  $-5.5\text{V}$  for V.10, V.11 (Notes 2, 3)

SYMBOL	PARAMETER	CONDITIONS	MIN	TYP	MAX	UNITS
$P_D$	Internal Power Dissipation (DCE Mode, All Digital Pins = GND or $V_{IN}$ )	RS530, RS530-A, X.21 Modes, Full Load		300		mW
		V.28 Mode, Full Load		54		mW

**Logic Inputs and Outputs**

$V_{IH}$	Logic Input High Voltage		●	2		V
$V_{IL}$	Logic Input Low Voltage		●		0.8	V
$I_{IN}$	Logic Input Current	D1, D2, D3, D4	●		$\pm 10$	$\mu\text{A}$
		M0, M1, M2, DCE = GND	●	-30	-75	$\mu\text{A}$
		M0, M1, M2, DCE = $V_{IN}$	●		$\pm 10$	$\mu\text{A}$
$V_{OH}$	Output High Voltage	$I_O = -3\text{mA}$	●	2.7	3	V
$V_{OL}$	Output Low Voltage	$I_O = 1.6\text{mA}$	●		0.2 0.4	V
$I_{OSR}$	Output Short-Circuit Current	$0\text{V} \leq V_O \leq V_{IN}$	●		$\pm 50$	mA
$I_{OZR}$	Three-State Output Current	$M0 = M1 = M2 = V_{IN}, V_O = 0\text{V}$	●	-30	-85	$\mu\text{A}$
		$M0 = M1 = M2 = V_{IN}, V_O = V_{IN}$	●		$\pm 10$	$\mu\text{A}$

**V.11 Driver**

$V_{ODO}$	Open Circuit Differential Output Voltage	$R_L = 1.95\text{k}$ (Figure 1)	●		$\pm 5$	V
$V_{ODL}$	Loaded Differential Output Voltage	$R_L = 50\Omega$ (Figure 1)	●	$0.5V_{ODO}$	$0.67V_{ODO}$	V
			●	$\pm 2$		V
$\Delta V_{OD}$	Change in Magnitude of Differential Output Voltage	$R_L = 50\Omega$ (Figure 1)	●		0.2	V
$V_{OC}$	Common Mode Output Voltage	$R_L = 50\Omega$ (Figure 1)	●		3	V
$\Delta V_{OC}$	Change in Magnitude of Common Mode Output Voltage	$R_L = 50\Omega$ (Figure 1)	●		0.2	V
$I_{SS}$	Short-Circuit Current	$V_{OUT} = \text{GND}$			$\pm 150$	mA
$I_{OZ}$	Output Leakage Current	$-0.25\text{V} \leq V_O \leq 0.25\text{V}$ , Power Off or No-Cable Mode or Driver Disabled	●		$\pm 1$ $\pm 100$	$\mu\text{A}$
$t_r, t_f$	Rise or Fall Time	LTC2844C (Figures 2, 5)	●	2	15 25	ns
		LTC2844I (Figures 2, 5)	●	2	15 35	ns
$t_{PLH}$	Input to Output	LTC2844C (Figures 2, 5)	●	20	40 65	ns
		LTC2844I (Figures 2, 5)	●	20	40 75	ns
$t_{PHL}$	Input to Output	LTC2844C (Figures 2, 5)	●	20	40 65	ns
		LTC2844I (Figures 2, 5)	●	20	40 75	ns
$\Delta t$	Input to Output Difference, $ t_{PLH} - t_{PHL} $	LTC2844C (Figures 2, 5)	●	0	3 12	ns
		LTC2844I (Figures 2, 5)	●	0	3 17	ns
$t_{SKEW}$	Output to Output Skew	(Figures 2, 5)			3	ns

**V.11 Receiver**

$V_{TH}$	Input Threshold Voltage	$-7\text{V} \leq V_{CM} \leq 7\text{V}$	●	-0.2	0.2	V
$\Delta V_{TH}$	Input Hysteresis	$-7\text{V} \leq V_{CM} \leq 7\text{V}$	●		15 40	mV
$I_{IN}$	Input Current (A, B)	$-10\text{V} \leq V_{A,B} \leq 10\text{V}$	●		$\pm 0.66$	mA
$R_{IN}$	Input Impedance	$-10\text{V} \leq V_{A,B} \leq 10\text{V}$	●	15	30	$\text{k}\Omega$
$t_r, t_f$	Rise or Fall Time	(Figures 2, 6)			15	ns
$t_{PLH}$	Input to Output	LTC2844C $C_L = 50\text{pF}$ (Figures 2, 6)	●		50 80	ns
		LTC2844I $C_L = 50\text{pF}$ (Figures 2, 6)	●		50 90	ns

**ELECTRICAL CHARACTERISTICS** The ● denotes specifications which apply over the full operating temperature range, otherwise specifications are at  $T_A = 25^\circ\text{C}$ .  $V_{CC} = 5\text{V}$ ,  $V_{IN} = 3.3\text{V}$ ,  $V_{DD} = 8\text{V}$ ,  $V_{EE} = -7\text{V}$  for V.28,  $-5.5\text{V}$  for V.10, V.11 (Notes 2, 3)

SYMBOL	PARAMETER	CONDITIONS		MIN	TYP	MAX	UNITS
$t_{PHL}$	Input to Output	LTC2844C $C_L = 50\text{pF}$ (Figures 2, 6) LTC2844I $C_L = 50\text{pF}$ (Figures 2, 6)	● ●		50 50	80 90	ns ns
$\Delta t$	Input to Output Difference, $ t_{PLH} - t_{PHL} $	LTC2844C $C_L = 50\text{pF}$ (Figures 2, 6) LTC2844I $C_L = 50\text{pF}$ (Figures 2, 6)	● ●	0 0	4 4	16 21	ns ns

**V.10 Driver**

$V_O$	Output Voltage	Open Circuit, $R_L = 3.9\text{k}$	●	$\pm 4$		$\pm 6$	V
$V_T$	Output Voltage	$R_L = 450\Omega$ (Figure 3) $R_L = 450\Omega$ (Figure 3)	●	$\pm 3.6$ $0.9V_O$			V
$I_{SS}$	Short-Circuit Current	$V_O = \text{GND}$				$\pm 150$	mA
$I_{OZ}$	Output Leakage Current	$-0.25\text{V} \leq V_O \leq 0.25\text{V}$ , Power Off or No-Cable Mode or Driver Disabled	●		$\pm 0.1$	$\pm 100$	$\mu\text{A}$
$t_r, t_f$	Rise or Fall Time	$R_L = 450\Omega$ , $C_L = 100\text{pF}$ (Figures 3, 7)			2		$\mu\text{s}$
$t_{PLH}$	Input to Output	$R_L = 450\Omega$ , $C_L = 100\text{pF}$ (Figures 3, 7)			1		$\mu\text{s}$
$t_{PHL}$	Input to Output	$R_L = 450\Omega$ , $C_L = 100\text{pF}$ (Figures 3, 7)			1		$\mu\text{s}$

**V.10 Receiver**

$V_{TH}$	Receiver Input Threshold Voltage		●	$-0.25$		0.25	V
$\Delta V_{TH}$	Receiver Input Hysteresis		●		25	50	mV
$I_{IN}$	Receiver Input Current	$-10\text{V} \leq V_A \leq 10\text{V}$	●			$\pm 0.66$	mA
$R_{IN}$	Receiver Input Impedance	$-10\text{V} \leq V_A \leq 10\text{V}$	●	15	30		$\text{k}\Omega$
$t_r, t_f$	Rise or Fall Time	$C_L = 50\text{pF}$ (Figures 4, 8)			15		ns
$t_{PLH}$	Input to Output	$C_L = 50\text{pF}$ (Figures 4, 8)			55		ns
$t_{PHL}$	Input to Output	$C_L = 50\text{pF}$ (Figures 4, 8)			109		ns
$\Delta t$	Input to Output Difference, $ t_{PLH} - t_{PHL} $	$C_L = 50\text{pF}$ (Figures 4, 8)			60		ns

**V.28 Driver**

$V_O$	Output Voltage	Open Circuit $R_L = 3\text{k}$ (Figure 3)	● ●	$\pm 5$		$\pm 10$	V V
$I_{SS}$	Short-Circuit Current	$V_O = \text{GND}$	●			$\pm 150$	mA
$I_{OZ}$	Output Leakage Current	$-0.25\text{V} \leq V_O \leq 0.25\text{V}$ , Power Off or No-Cable Mode or Driver Disabled	●		$\pm 1$	$\pm 100$	$\mu\text{A}$
SR	Slew Rate	$R_L = 3\text{k}$ , $C_L = 2500\text{pF}$ (Figures 3, 7)	●	4		30	V/ $\mu\text{s}$
$t_{PLH}$	Input to Output	$R_L = 3\text{k}$ , $C_L = 2500\text{pF}$ (Figures 3, 7)	●		1.3	2.5	$\mu\text{s}$
$t_{PHL}$	Input to Output	$R_L = 3\text{k}$ , $C_L = 2500\text{pF}$ (Figures 3, 7)	●		1.3	2.5	$\mu\text{s}$

**V.28 Receiver**

$V_{THL}$	Input Low Threshold Voltage		●			0.8	V
$V_{TLH}$	Input High Threshold Voltage		●	2			V
$\Delta V_{TH}$	Receiver Input Hysteresis		●		0.1	0.3	V
$R_{IN}$	Receiver Input Impedance	$-15\text{V} \leq V_A \leq 15\text{V}$	●	3	5	7	$\text{k}\Omega$
$t_r, t_f$	Rise or Fall Time	$C_L = 50\text{pF}$ (Figures 4, 8)			15		ns
$t_{PLH}$	Input to Output	$C_L = 50\text{pF}$ (Figures 4, 8)	●		60	100	ns
$t_{PHL}$	Input to Output	$C_L = 50\text{pF}$ (Figures 4, 8)	●		150	500	ns

## ELECTRICAL CHARACTERISTICS

**Note 1:** Absolute Maximum Ratings are those values beyond which the life of a device may be impaired.

**Note 2:** All currents into device pins are positive; all currents out of device are negative. All voltages are referenced to device ground unless otherwise specified.

**Note 3:** All typicals are given for  $V_{CC} = 5V$ ,  $V_{IN} = 3.3V$ ,  $V_{DD} = 8V$ ,  $V_{EE} = -7V$  for V.28,  $-5.5V$  for V.10, V.11 and  $T_A = 25^\circ C$ .

## PIN FUNCTIONS

**$V_{CC}$  (Pin 1):** Positive Supply for the Transceivers. Connect to  $V_{CC}$  Pin 8 on LTC2846 or to 5V supply. Connect a  $1\mu F$  capacitor to ground.

**$V_{DD}$  (Pin 2):** Positive Supply Voltage for V.28. Connect to  $V_{DD}$  Pin 7 on LTC2846 or 8V supply. Connect a  $1\mu F$  capacitor to ground.

**D1 (Pin 3):** TTL Level Driver 1 Input.

**D2 (Pin 4):** TTL Level Driver 2 Input.

**D3 (Pin 5):** TTL Level Driver 3 Input.

**R1 (Pin 6):** CMOS Level Receiver 1 Output. Receiver outputs have a weak pull up to  $V_{IN}$  when high impedance.

**R2 (Pin 7):** CMOS Level Receiver 2 Output.

**R3 (Pin 8):** CMOS Level Receiver 3 Output.

**D4 (Pin 9):** TTL Level Driver 4 Input.

**R4 (Pin 10):** CMOS Level Receiver 4 Output.

**M0 (Pin 11):** TTL Level Mode Select Input 0. Mode select inputs pull up to  $V_{IN}$ .

**M1 (Pin 12):** TTL Level Mode Select Input 1.

**M2 (Pin 13):** TTL Level Mode Select Input 2.

**DCE/DTE (Pin 14):** TTL Level Mode Select Input.

**$V_{IN}$  (Pin 15):** Positive Supply for the Receiver Outputs.  $3V \leq V_{IN} \leq 3.6V$ . Connect a  $1\mu F$  capacitor to ground.

**D4/R4 A (Pin 16):** Receiver 4 Inverting Input and Driver 4 Output.

**R3 B (Pin 17):** Receiver 3 Noninverting Input.

**R3 A (Pin 18):** Receiver 3 Inverting Input.

**R2 B (Pin 19):** Receiver 2 Noninverting Input.

**R2 A (Pin 20):** Receiver 2 Inverting Input.

**D3/R1 B (Pin 21):** Receiver 1 Noninverting Input and Driver 3 Noninverting Output.

**D3/R1 A (Pin 22):** Receiver 1 Inverting Input and Driver 3 Inverting Output.

**D2 B (Pin 23):** Driver 2 Noninverting Output.

**D2 A (Pin 24):** Driver 2 Inverting Output.

**D1 B (Pin 25):** Driver 1 Noninverting Output.

**D1 A (Pin 26):** Driver 1 Inverting Output.

**GND (Pin 27):** Ground.

**$V_{EE}$  (Pin 28):** Negative Supply Voltage. Connect to  $V_{EE}$  Pin 31 on LTC2846 or to  $-7V$  supply. Connect a  $1\mu F$  capacitor to ground.

**BLOCK DIAGRAM**

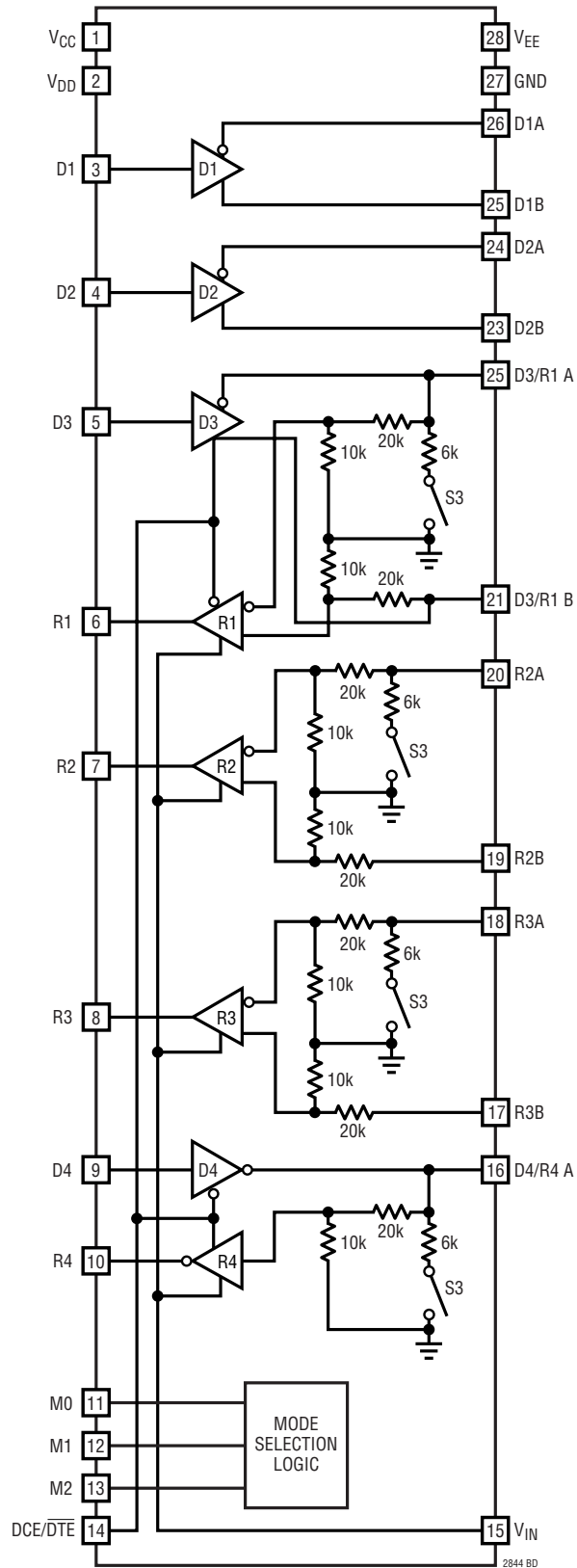

## TEST CIRCUITS

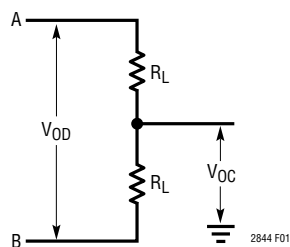

Figure 1. V.11 Driver Test Circuit

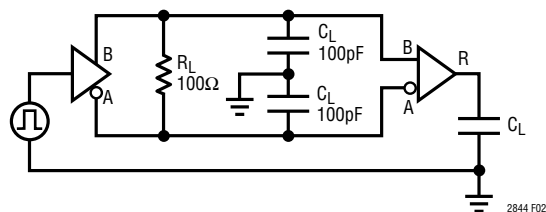

Figure 2. V.11 Driver/Receiver AC Test Circuit

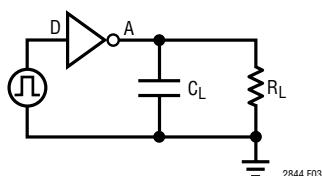

Figure 3. V.10/V.28 Driver Test Circuit

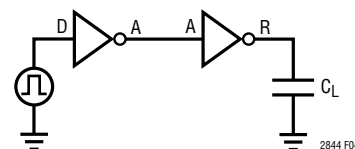

Figure 4. V.10/V.28 Receiver Test Circuit

## MODE SELECTION

LTC2844 MODE NAME	M2	M1	M0	DCE/DTE	D1	D2	D3	R1	R2	R3	D4	R4
Not Used (Default V.11)	0	0	0	0	V.11	V.11	Z	V.11	V.11	V.11	V.10	Z
RS530A	0	0	1	0	V.11	V.10	Z	V.11	V.10	V.11	V.10	Z
RS530	0	1	0	0	V.11	V.11	Z	V.11	V.11	V.11	V.10	Z
X.21	0	1	1	0	V.11	V.11	Z	V.11	V.11	V.11	V.10	Z
V.35	1	0	0	0	V.28	V.28	Z	V.28	V.28	V.28	V.28	Z
RS449/V.36	1	0	1	0	V.11	V.11	Z	V.11	V.11	V.11	V.10	Z
V.28/RS232	1	1	0	0	V.28	V.28	Z	V.28	V.28	V.28	V.28	Z
No Cable	1	1	1	0	Z	Z	Z	Z	Z	Z	Z	Z
Not Used (Default V.11)	0	0	0	1	V.11	V.11	V.11	Z	V.11	V.11	Z	V.10
RS530A	0	0	1	1	V.11	V.10	V.11	Z	V.10	V.11	Z	V.10
RS530	0	1	0	1	V.11	V.11	V.11	Z	V.11	V.11	Z	V.10
X.21	0	1	1	1	V.11	V.11	V.11	Z	V.11	V.11	Z	V.10
V.35	1	0	0	1	V.28	V.28	V.28	Z	V.28	V.28	Z	V.28
RS449/V.36	1	0	1	1	V.11	V.11	V.11	Z	V.11	V.11	Z	V.10
V.28/RS232	1	1	0	1	V.28	V.28	V.28	Z	V.28	V.28	Z	V.28
No Cable	1	1	1	1	Z	Z	Z	Z	Z	Z	Z	Z

# SWITCHING TIME WAVEFORMS

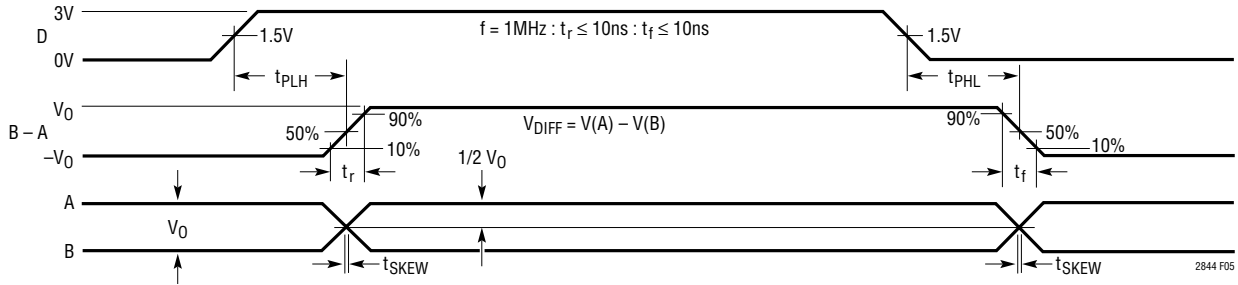

Figure 5. V.11, V.35 Driver Propagation Delays

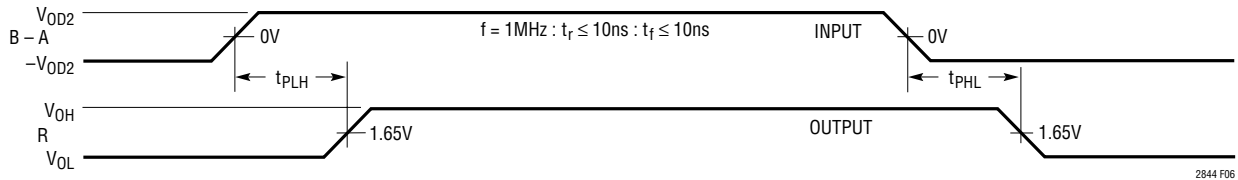

Figure 6. V.11, V.35 Receiver Propagation Delays



Figure 7. V.10, V.28 Driver Propagation Delays

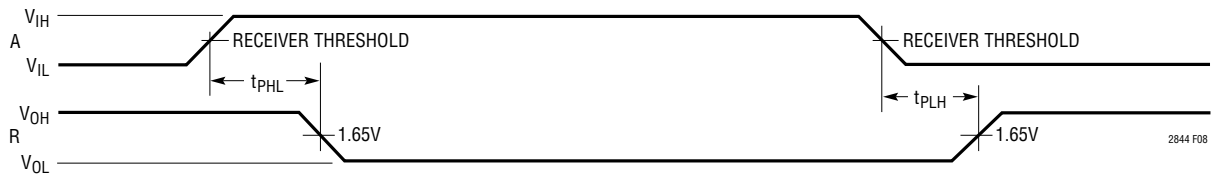

Figure 8. V.10, V.28 Receiver Propagation Delays



## APPLICATIONS INFORMATION

### Overview

The LTC2846/LTC2844 form the core of a complete software-selectable DTE or DCE interface port that supports the RS232, RS449, EIA530, EIA530-A, V.35, V.36 or X.21 protocols.

A complete DCE-to-DTE interface operating in EIA530 mode is shown in Figure 9. The LTC2846 of each port is used to generate the clock and data signals. The LTC2844 is used to generate the control signals along with LL (local loop-back). Cable termination is used only for the clock and data signals. The control signals do not need any external resistors.

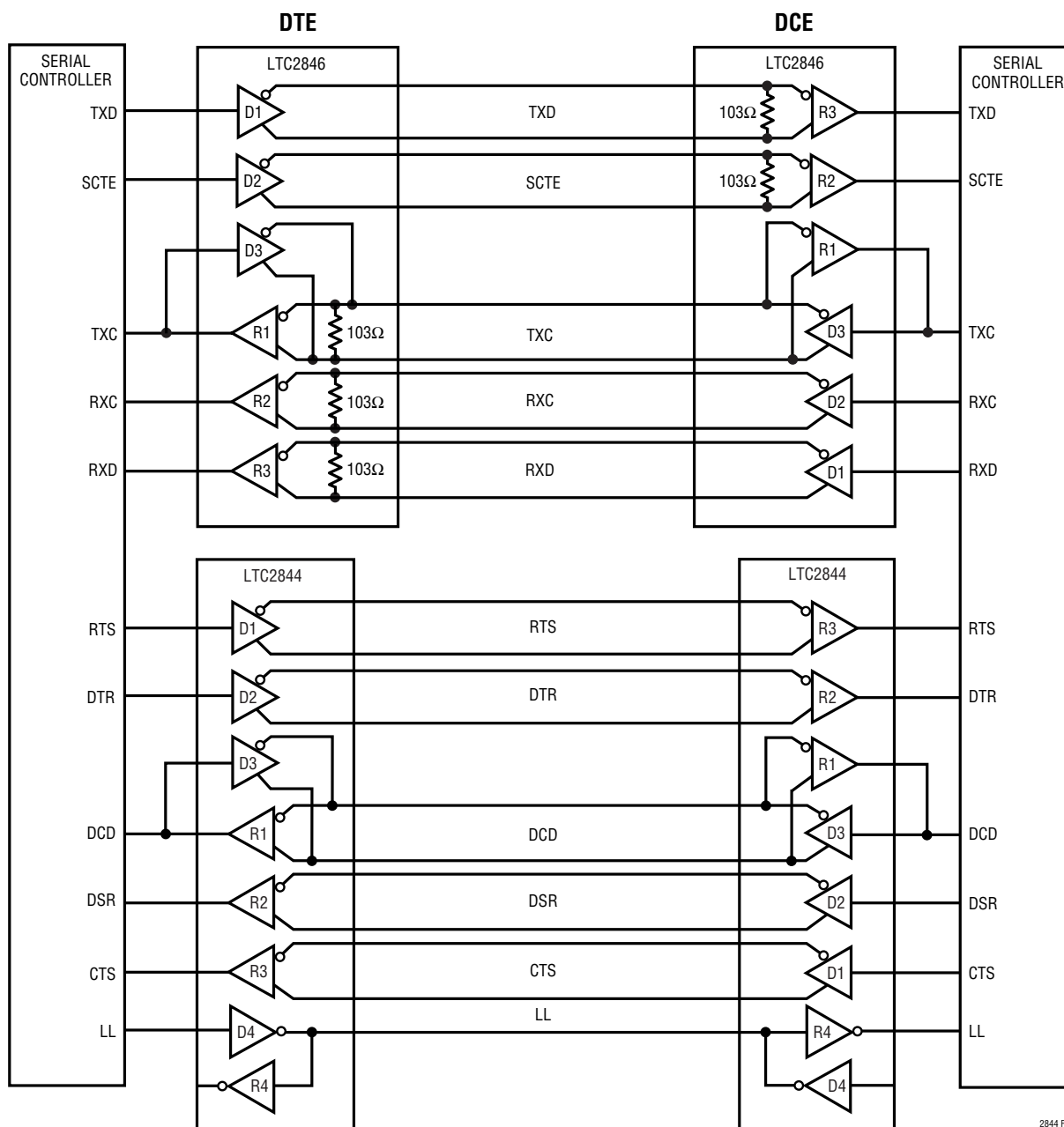

2844 F09

Figure 9. Complete Multiprotocol Interface in EIA530 Mode

## APPLICATIONS INFORMATION

### Mode Selection

The interface protocol is selected using the mode select pins M0, M1 and M2 (see the Mode Selection table).

For example, if the port is configured as a V.35 interface, the mode selection pins should be M2 = 1, M1 = 0, M0 = 0. For the control signals, the drivers and receivers will operate in V.28 (RS232) electrical mode. For the clock and data signals, the drivers and receivers will operate in V.35 electrical mode. The DCE/ $\overline{\text{DTE}}$  pin will configure the port for DCE mode when high, and DTE when low.

The interface protocol may be selected simply by plugging the appropriate interface cable into the connector. The mode pins are routed to the connector and are left unconnected (1) or wired to ground (0) in the cable as shown in Figure 10.

The internal pull-up current sources will ensure a binary 1 when a pin is left unconnected and that the LTC2846/LTC2844 enter the no-cable mode when the cable is removed. In the no-cable mode the LTC2846/LTC2844 supply current drops to less than 1200 $\mu\text{A}$  and all driver outputs are forced into a high impedance state.

The mode selection may also be accomplished by using jumpers to connect the mode pins to ground or  $V_{\text{IN}}$ .

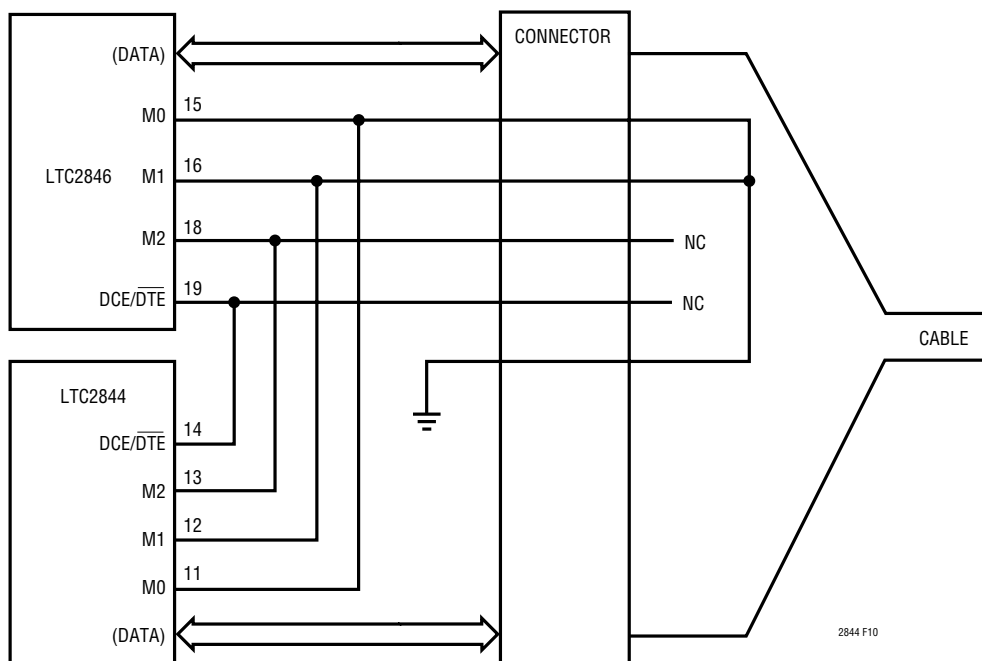

Figure 10: Single Port DCE V.35 Mode Selection in the Cable

2844 F10

## APPLICATIONS INFORMATION

### Cable Termination

Traditional implementations have included switching resistors with expensive relays, or required the user to change termination modules every time the interface standard has changed. Custom cables have been used with the termination in the cable head or separate terminations are built on the board and a custom cable routes the signals to the appropriate termination. Switching the termination with FETs is difficult because the FETs must remain off even though the signal voltage is beyond the supply voltage for the FET drivers or the power is off.

Using the LTC2846/LTC2844 solves the cable termination switching problem. Via software control, appropriate termination for the V.10 (RS423), V.11 (RS422), V.28 (RS232) and V.35 electrical protocols is chosen.

### V.10 (RS423) Interface

A typical V.10 unbalanced interface is shown in Figure 11. A V.10 single-ended generator output A with ground C is connected to a differential receiver with inputs A' connected to A, and input C' connected to the signal return ground C. Usually, no cable termination is required for V.10 interfaces, but the receiver inputs must be compliant with the impedance curve shown in Figure 12.

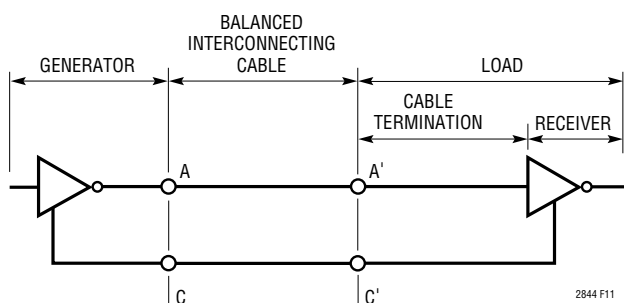

Figure 11. Typical V.10 Interface

The V.10 receiver configuration in the LTC2844 is shown in Figure 13. In V.10 mode switch S3 inside the LTC2844 is turned off. The noninverting input is disconnected inside the LTC2844 receiver and connected to ground. The cable termination is then the 30k input impedance to ground of the LTC2844 V.10 receiver.

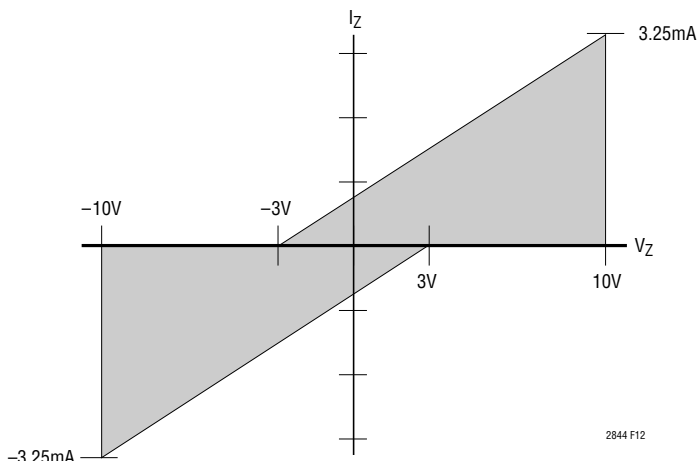

Figure 12. V.10 Receiver Input Impedance

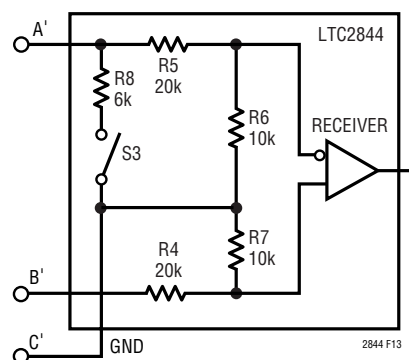

Figure 13. V.10 Receiver Configuration

## APPLICATIONS INFORMATION

### V.11 (RS422) Interface

A typical V.11 balanced interface is shown in Figure 14. A V.11 differential generator with outputs A and B with ground C is connected to a differential receiver with ground C', inputs A' connected to A, B' connected to B. The V.11 interface has a differential termination at the receiver end that has a minimum value of 100Ω. The termination resistor is optional in the V.11 specification, but for the high speed clock and data lines, the termination is required to prevent reflections from corrupting the data. The receiver inputs must also be compliant with the impedance curve shown in Figure 12.

In V.11 mode, all switches are off except S1 of the LTC2846's receivers which connects a 103Ω differential termination impedance to the cable as shown in Figure 15<sup>1</sup>. The LTC2844 only handles control signals, so no termination other than its V.11 receivers' 30k input impedance is necessary.

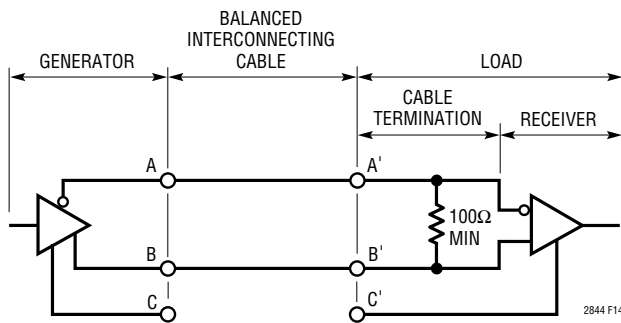

Figure 14. Typical V.11 Interface

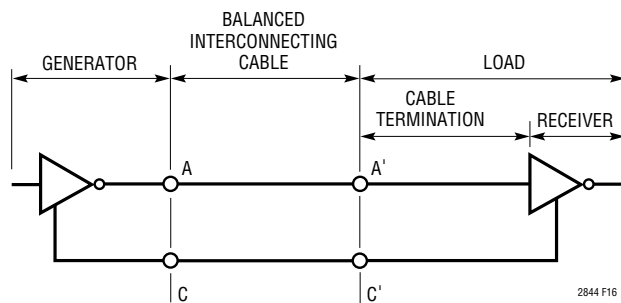

Figure 16. Typical V.28 Interface

### V.28 (RS232) Interface

A typical V.28 unbalanced interface is shown in Figure 16. A V.28 single-ended generator output A with ground C is connected to a single-ended receiver with input A' connected to A, ground C' connected via the signal return ground C.

In V.28 mode all switches are off except S3 inside the LTC2846/LTC2844 which connects a 6k (R8) impedance to ground in parallel with 20k (R5) plus 10k (R6) for a combined impedance of 5k as shown in Figure 17. The noninverting input is disconnected inside the LTC2846/LTC2844 receiver and connected to a TTL level reference voltage for a 1.4V receiver trip point.

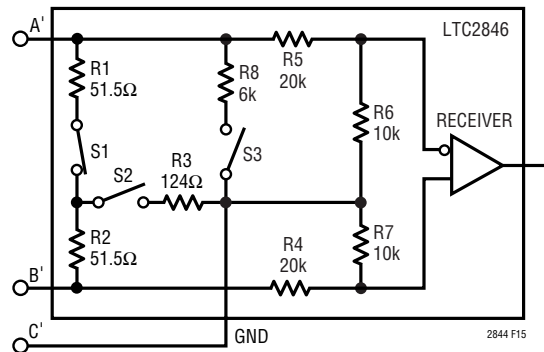

Figure 15. V.11 Receiver Configuration

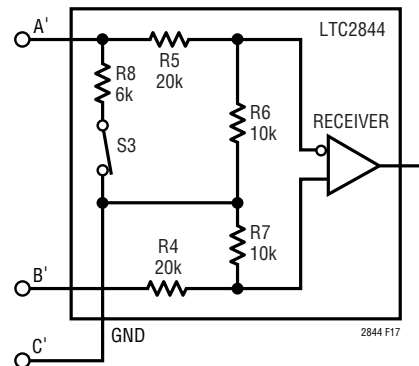

Figure 17. V.28 Receiver Configuration

<sup>1</sup>Actually, there is no switch S1 in receivers R2 and R3. However, for simplicity, all termination networks on the LTC2846 can be treated identically if it is assumed that an S1 switch exists and is always closed on the R2 and R3 receivers.

## APPLICATIONS INFORMATION

### V.35 Interface

A typical V.35 balanced interface is shown in Figure 18. A V.35 differential generator with outputs A and B with ground C is connected to a differential receiver with ground C', inputs A' connected to A, B' connected to B. The V.35 interface requires a T or delta network termination at the receiver end and the generator end. The receiver differential impedance measured at the connector must be  $100\Omega \pm 10\Omega$ , and the impedance between shorted terminals (A' and B') and ground C' must be  $150\Omega \pm 15\Omega$ .

In V.35 mode, both switches S1 and S2 inside the LTC2844 are on, connecting the T network impedance as shown in Figure 19. The 30k input impedance of the receiver is placed in parallel with the T network termination, but does not affect the overall input impedance significantly.

The generator differential impedance must be  $50\Omega$  to  $150\Omega$  and the impedance between shorted terminals (A and B) and ground C must be  $150\Omega \pm 15\Omega$ . For the generator termination, switches S1 and S2 are both on as shown in Figure 20.

### No-Cable Mode

The no-cable mode ( $M0 = M1 = M2 = 1$ ) is intended for the case when the cable is disconnected from the connector. The bias circuitry, drivers and receivers are turned off, the driver outputs are forced into a high impedance state, and the supply current drops to less than  $1200\mu A$ .

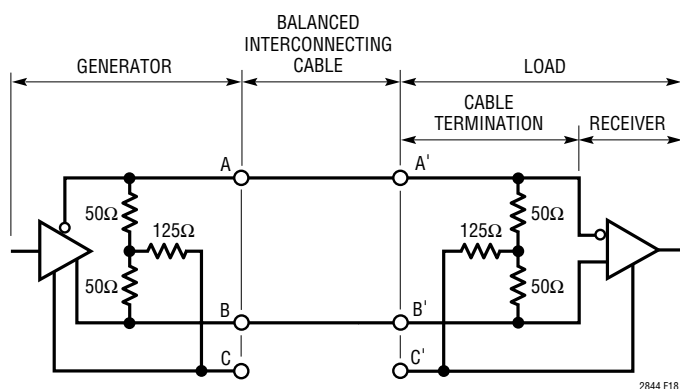

Figure 18. Typical V.35 Interface

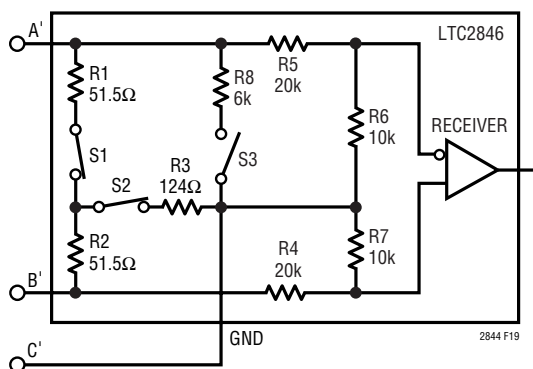

Figure 19. V.35 Receiver Configuration

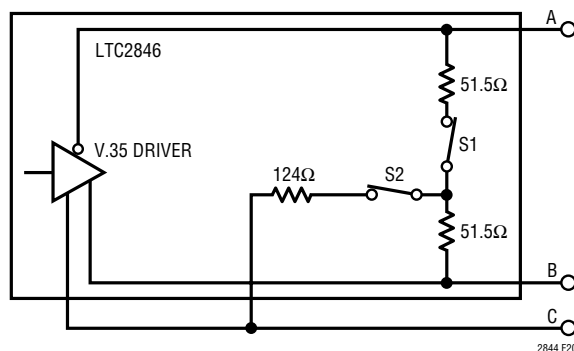

Figure 20. V.35 Driver

## APPLICATIONS INFORMATION

### LTC2846 Supplies

The LTC2846 uses an internal capacitive charge pump to generate  $V_{DD}$  and  $V_{EE}$  as shown in Figure 21. A voltage doubler generates about 8V on  $V_{DD}$  and a voltage inverter generates about  $-7.5V$  for  $V_{EE}$ . Three  $1\mu F$  surface mounted tantalum or ceramic capacitors are required for C1, C2 and C3. The  $V_{EE}$  capacitor C4 should be a minimum of  $3.3\mu F$ . All capacitors are 16V and should be placed as close as possible to the LTC2846 to reduce EMI.

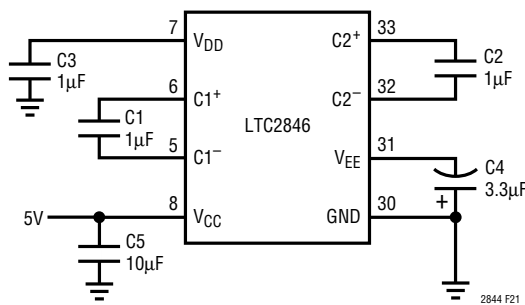

Figure 21. Charge Pump

The LTC2846 has an internal boost switching regulator which generates a 5V output from the 3.3V supply as shown in Figure 22. The 5V  $V_{CC}$  supplies its internal charge pump and transceivers as well as its companion chip.

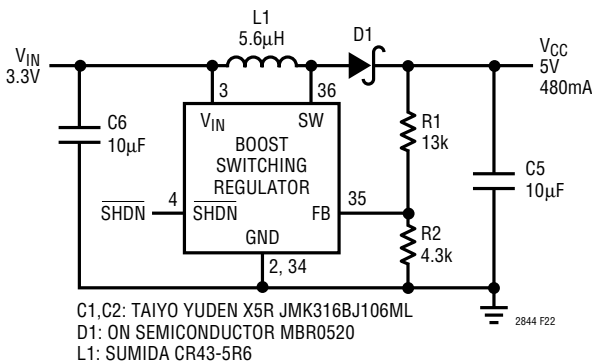

Figure 22. Boost Switching Regulator

### Receiver Fail-Safe

All LTC2846/LTC2844 receivers feature fail-safe operation in all modes. If the receiver inputs are left floating or shorted together by a termination resistor, the receiver output will always be forced to a logic high.

### DTE vs DCE Operation

The DCE/ $\overline{DTE}$  pin acts as an enable for Driver 3/Receiver 1 in the LTC2846, and Driver 3/Receiver 1 and Receiver 4/Driver 4 in the LTC2844.

The LTC2846/LTC2844 can be configured for either DTE or DCE operation in one of two ways: a dedicated DTE or DCE port with a connector of appropriate gender or a port with one connector that can be configured for DTE or DCE operation by rerouting the signals to the LTC2846/LTC2844 using a dedicated DTE cable or dedicated DCE cable.

A dedicated DTE port using a DB-25 male connector is shown in Figure 23. The interface mode is selected by logic outputs from the controller or from jumpers to either  $V_{IN}$  or GND on the mode select pins. A dedicated DCE port using a DB-25 female connector is shown in Figure 24.

A port with one DB-25 connector, but can be configured for either DTE or DCE operation is shown in Figure 25. The configuration requires separate cables for proper signal routing in DTE or DCE operation. For example, in DTE mode, the TXD signal is routed to Pins 2 and 14 via Driver 1 in the LTC2846. In DCE mode, Driver 1 now routes the RXD signal to Pins 2 and 14.

### Multiprotocol Interface with RL, LL, TM and a DB-25 Connector

If the RL, LL and TM signals are implemented, there are not enough drivers and receivers available in the LTC2846/LTC2844. In Figure 26, the required control signals are handled by the LTC2845. The LTC2845 has an additional single-ended driver/receiver pair that can handle two more optional control signals such as TM and LL.

### Cable-Selectable Multiprotocol Interface

A cable-selectable multiprotocol DTE/DCE interface is shown in Figure 27. The select lines M0, M1 and DCE/ $\overline{DTE}$  are brought out to the connector. The mode is selected by the cable by wiring M0 (connector Pin 18) and M1 (connector Pin 21) and DCE/ $\overline{DTE}$  (connector Pin 25) to ground (connector Pin 7) or letting them float. If M0, M1 or DCE/ $\overline{DTE}$  is floating, internal pull-up current sources will pull the signals to  $V_{IN}$ . The select bit M2 is floating and therefore, internally pulled high. When the cable is pulled out, the interface will go into the no-cable mode.

# TYPICAL APPLICATIONS

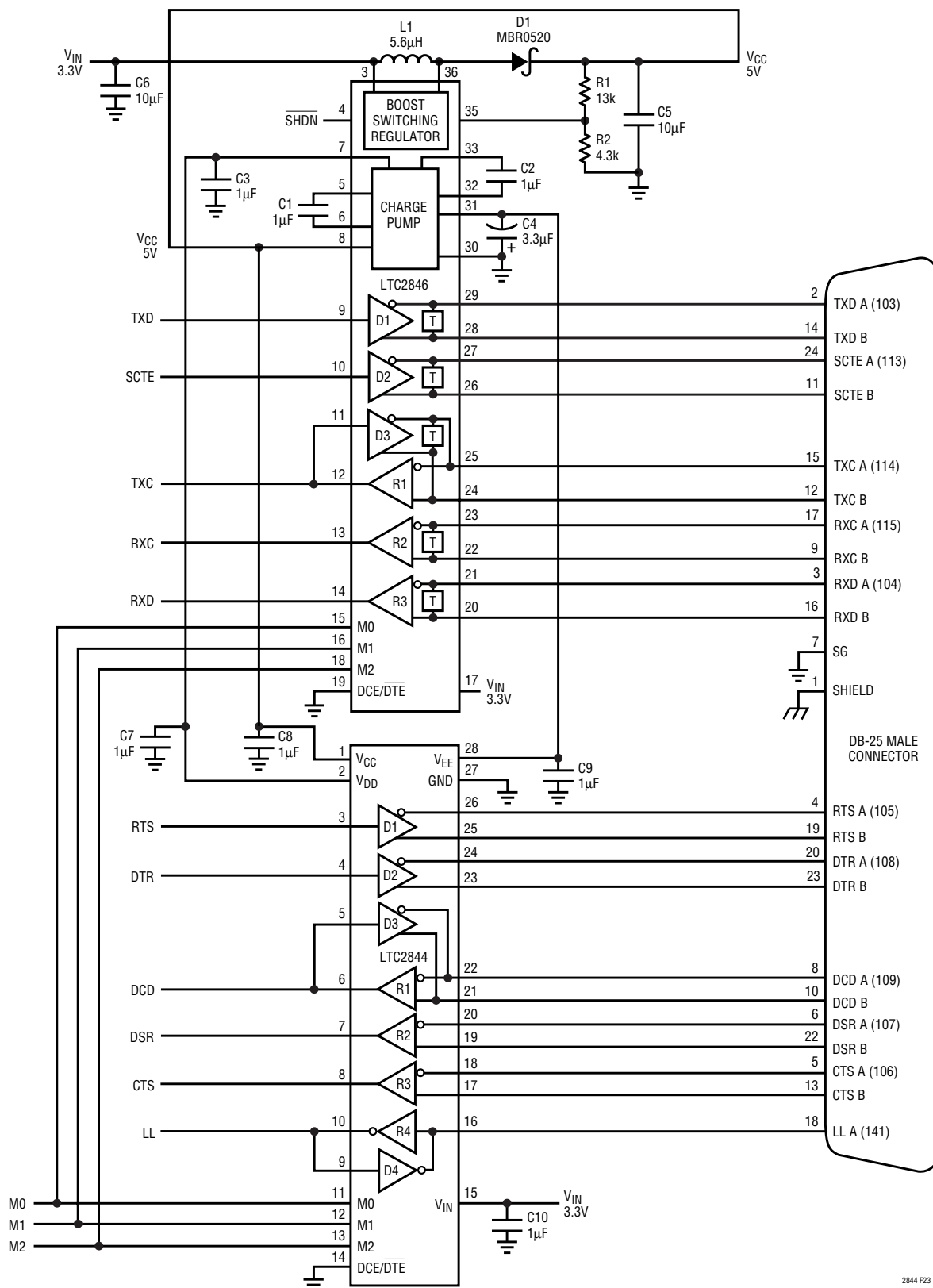

Figure 23. Controller-Selectable Multiprotocol DTE Port with DB-25 Connector

2844 F23

TYPICAL APPLICATIONS

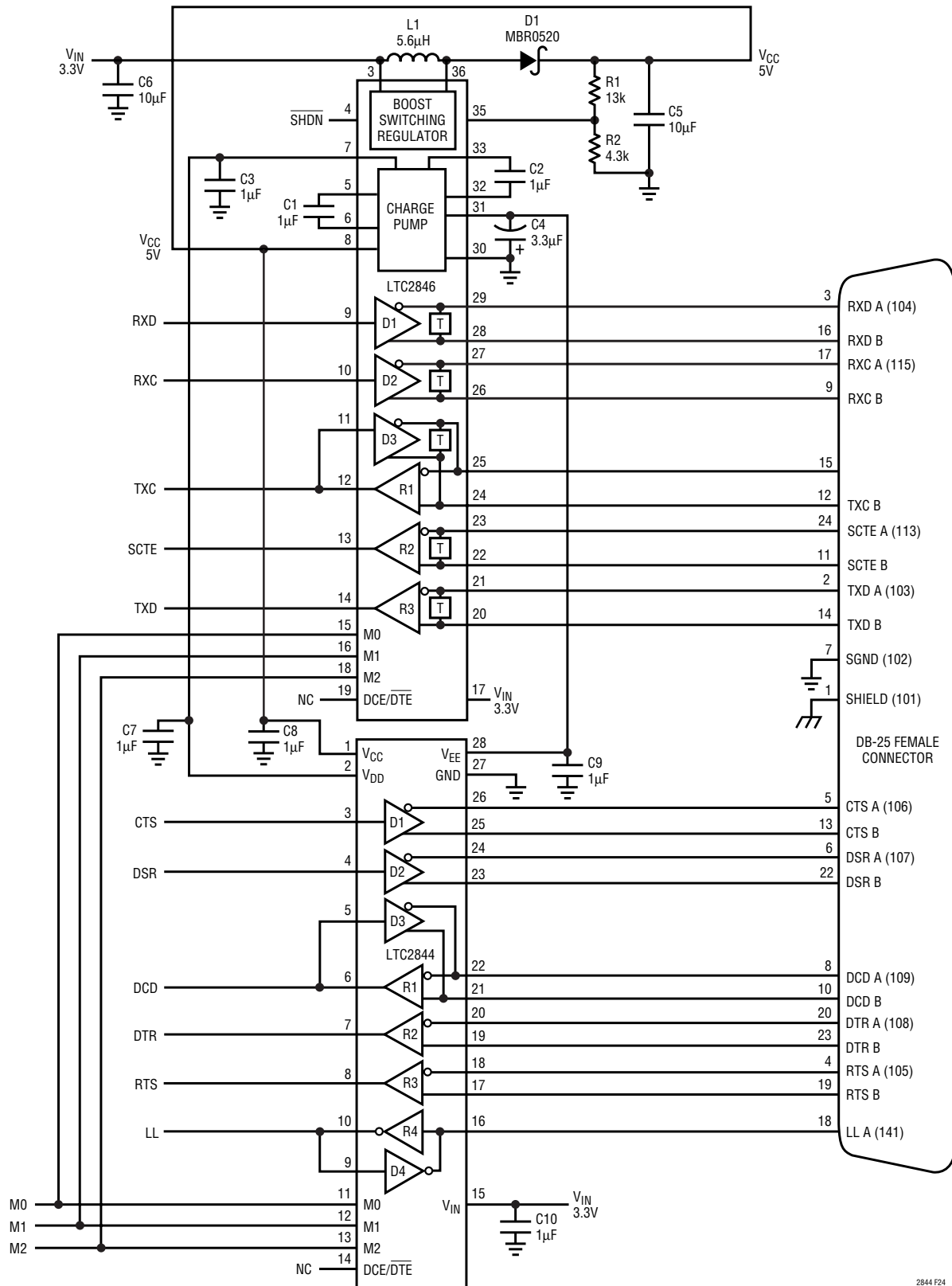

Figure 24. Controller-Selectable DCE Port with DB-25 Connector

2844 F24



# TYPICAL APPLICATIONS

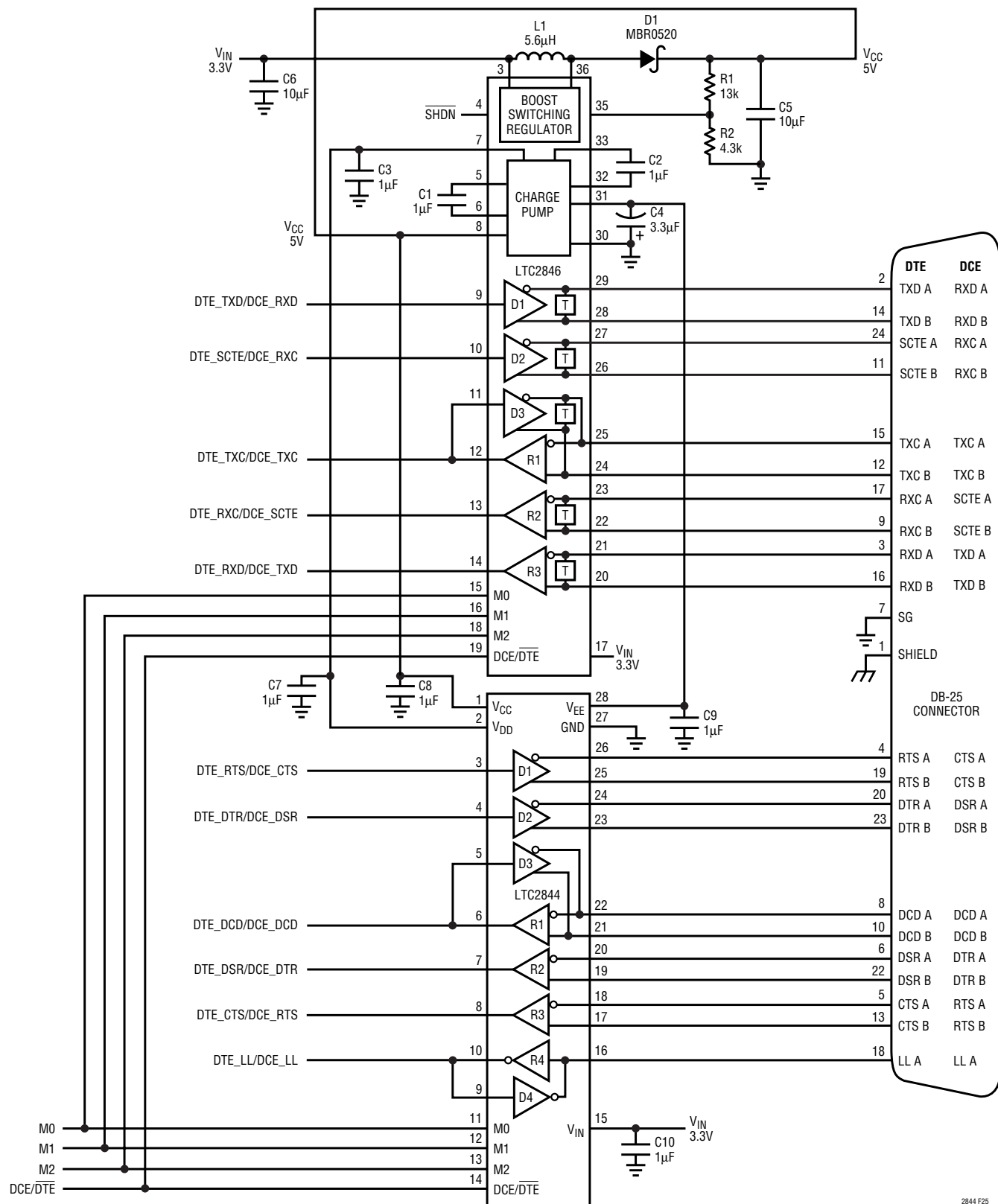

Figure 25. Controller-Selectable Multiprotocol DTE/DCE Port with DB-25 Connector

2844 F25

TYPICAL APPLICATIONS

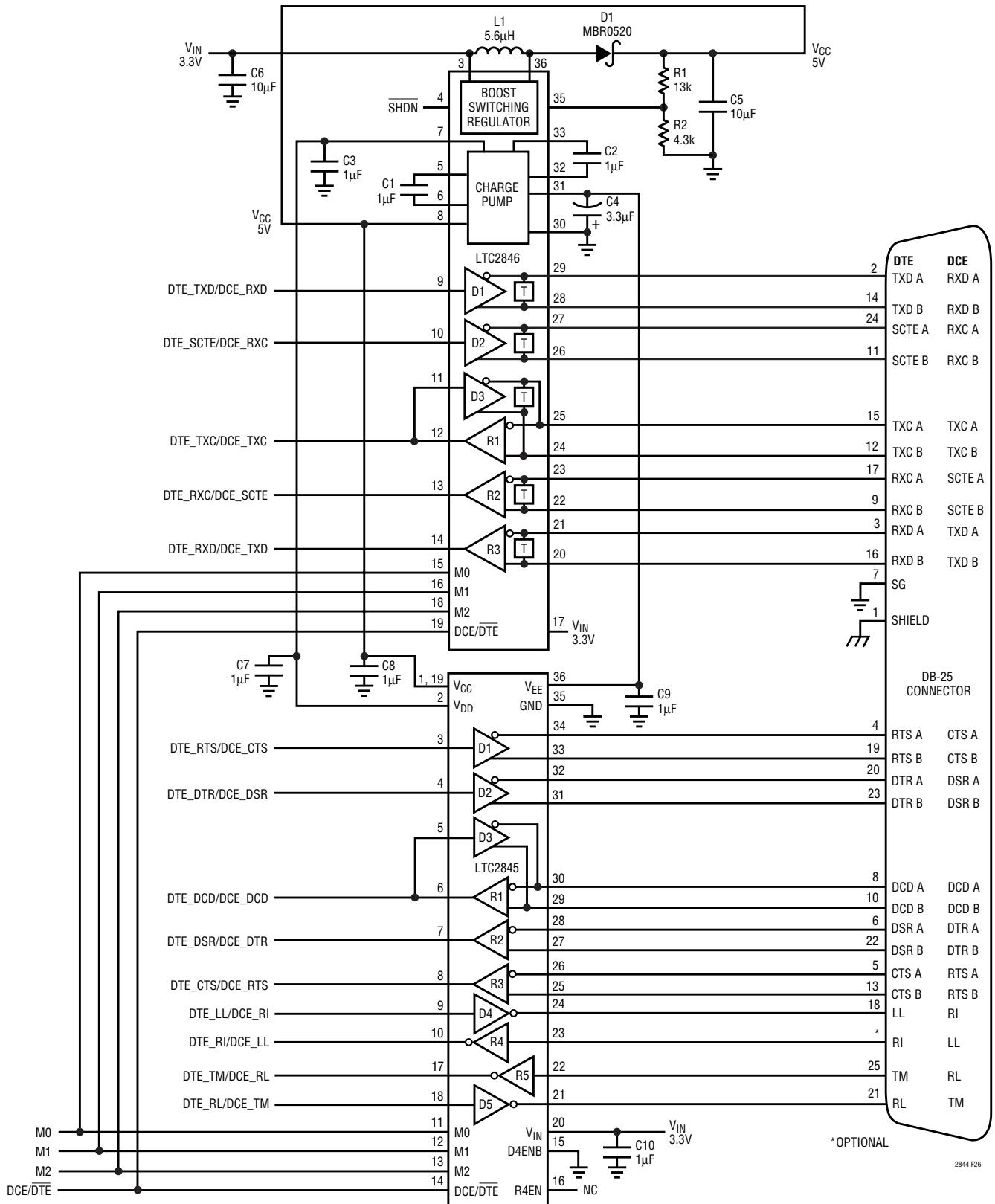

Figure 26. Controller-Selectable Multiprotocol DTE/DCE Port with RL, LL, TM and DB-25 Connector

2844 F26

# TYPICAL APPLICATIONS

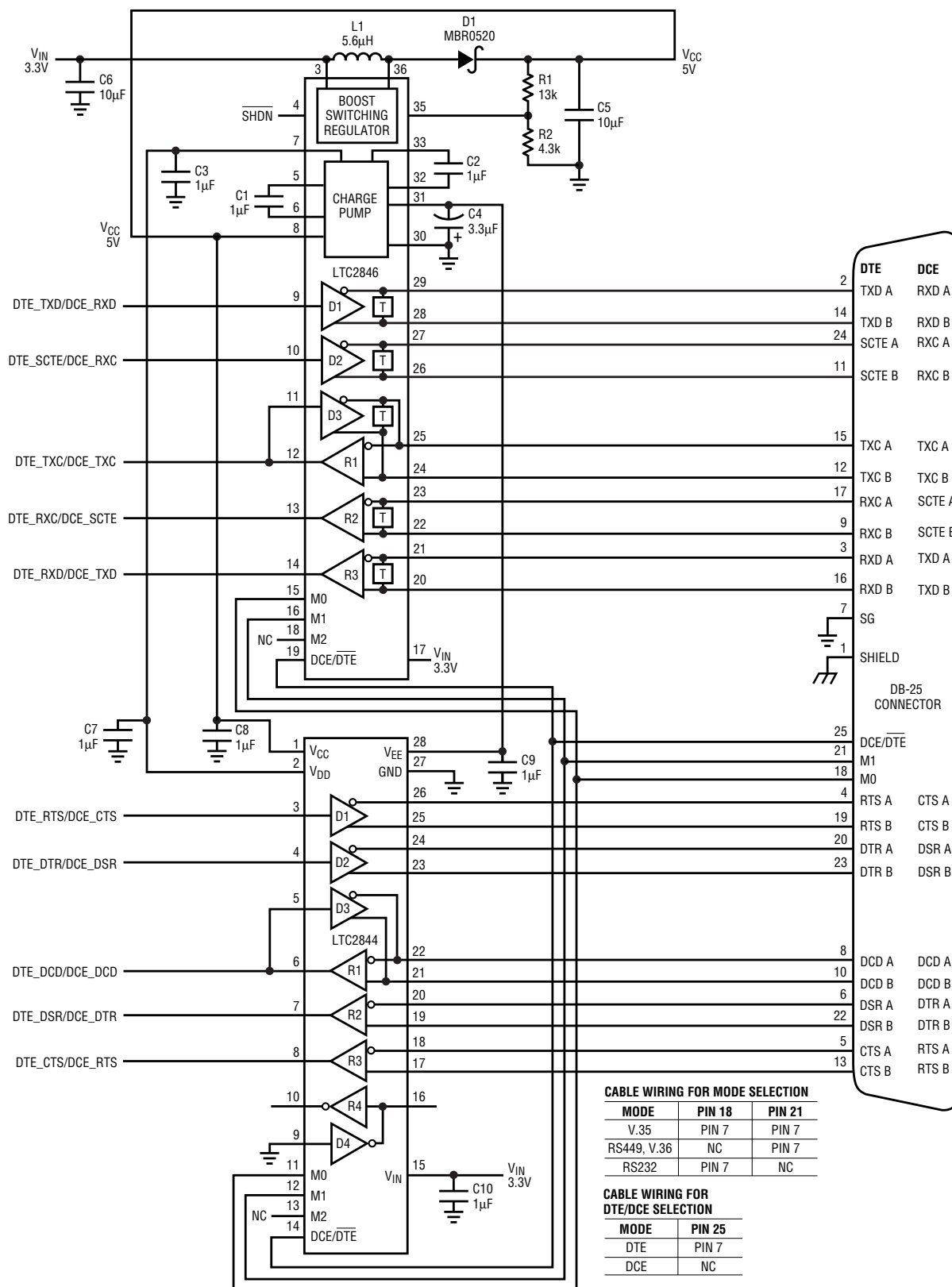
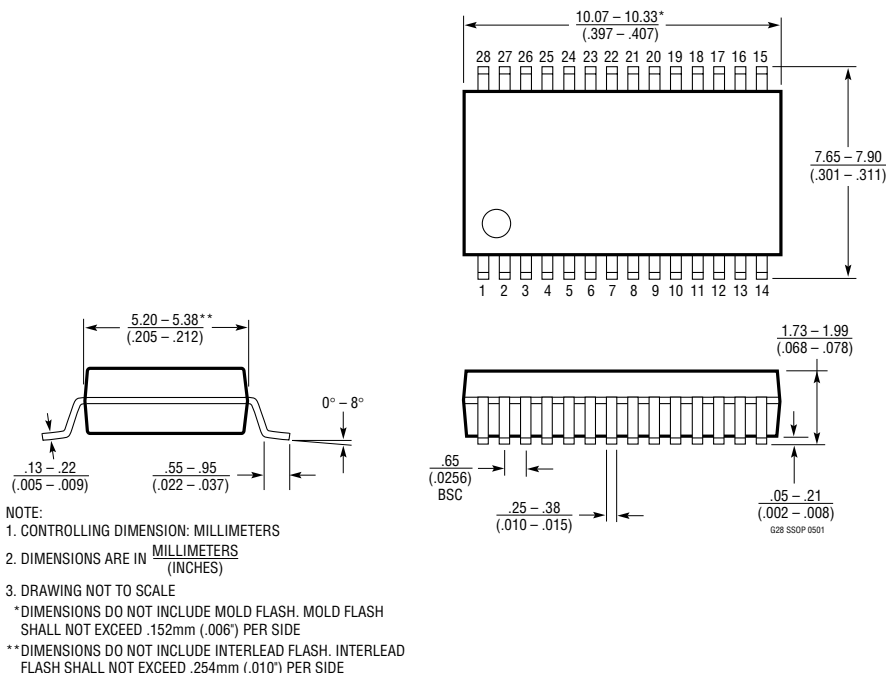

Figure 27. Cable-Selectable Multiprotocol DTE/DCE Port with DB-25 Connector

2844 F27

## PACKAGE DESCRIPTION

### G Package 28-Lead Plastic SSOP (5.3mm) (Reference LTC DWG # 05-08-1640)



## RELATED PARTS

PART NUMBER	DESCRIPTION	COMMENTS
LTC1321	Dual RS232/RS485 Transceiver	Two RS232 Driver/Receiver Pairs or Two RS485 Driver/Receiver Pairs
LTC1334	Single 5V RS232/RS485 Multiprotocol Transceiver	Two RS232 Driver/Receiver or Four RS232 Driver/Receiver Pairs
LTC1343	Software-Selectable Multiprotocol Transceiver	4-Driver/4-Receiver for Data and Clock Signals
LTC1344A	Software-Selectable Cable Terminator	Perfect for Terminating the LTC1543 (Not Needed with LTC1546)
LTC1345	Single Supply V.35 Transceiver	3-Driver/3-Receiver for Data and Clock Signals
LTC1346A	Dual Supply V.35 Transceiver	3-Driver/3-Receiver for Data and Clock Signals
LTC1543	Software-Selectable Multiprotocol Transceiver	Terminated with LTC1344A for Data and Clock Signals, Companion to LTC1544 or LTC1545 for Control Signals
LTC1544	Software-Selectable Multiprotocol Transceiver	Companion to LTC1546 or LTC1543 for Control Signals Including LL
LTC1545	Software-Selectable Multiprotocol Transceiver	5-Driver/5-Receiver Companion to LTC1546 or LTC1543 for Control Signals Including LL, TM and RL
LTC1546	Software-Selectable Multiprotocol Transceiver	3-Driver/3-Receiver with Termination for Data and Clock Signals
LTC2845	3.3V Software-Selectable Multiprotocol Transceiver	3.3V Supply, 5-Driver/5-Receiver Companion to LTC2846 for Control Including LL, TM and RL
LTC2846	3.3V Software-Selectable Multiprotocol Transceiver	3.3V Supply, 3-Driver/3-Receiver with Termination for Data and Clock Signals, Generates the Required 5V and ±8V Supplies for LTC2846 and Companion Parts

2844i