

# Single-phase DC Brushless Motor Driver IC

## ■ GENERAL DESCRIPTION

The NJU7342 is a single-phase DC brushless motor driver IC for small fan-motor applications. It features MOS-FET driver circuit for better saturation characteristics. Slew rate of amplifiers and feedback resistors are optimized to achieve low-noise motor operation.

It is suitable for small fan-motor applications.

## ■ PACKAGE OUTLINE

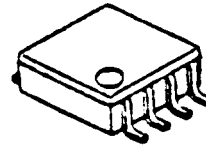

NJU7342R/RB1

## ■ FEATURES

- Operating Voltage  $V_{DD}=2.4 \sim 5.5V$
- Low Operating Current
- Low Saturation Output Voltage  
 $V_{sat}=\pm 0.35V @ I_o=\pm 250mA$
- C-MOS Technology
- Package Outline VSP8/TVSP8

## ■ BLOCK DIAGRAM

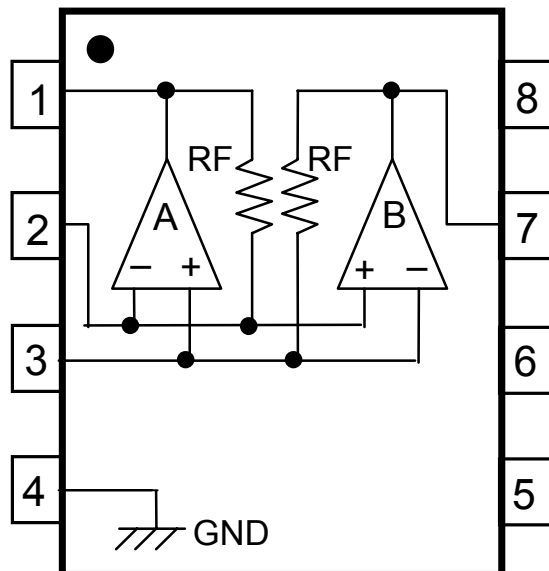

## ■ PIN FUNCTION

- 1: AOUT
- 2: AMP-IN
- 3: AMP+IN
- 4: GND
- 5: NC
- 6: NC
- 7: BOUT
- 8:  $V_{DD}$

# NJU7342

## ■ ABUSOLUTE MAXIMUM RATINGS

(Ta=25°C)

PARAMETER	RATINGS	SYMBOL (unit)	NOTE
Supply Voltage	+7	V <sub>DD</sub> (V)	
Input Voltage	-0.3 ~ V <sub>DD</sub> +0.3	V <sub>ID</sub> (V)	
Operating Temperature Range	-40 ~ +85	Topr (°C)	
Storage Temperature Range	-50 ~ +150	Tstg (°C)	
Power Dissipation	400	P <sub>D</sub> (mW)	Device itself

## ■ RECOMMENDED OPERATING CONDITIONS

V<sub>DD</sub>=2.4V~5.5V

## ■ ELECTRICAL CHARACTERISTICS

(Ta=25°C, V<sub>DD</sub>=5V)

PARAMETER	SYMBOL	CONDITION	MIN.	TYP.	MAX.	UNIT
Input Offset Voltage	V <sub>IO</sub>	-	-5	-	5	mV
Input Common Mode Voltage Range	V <sub>ICM</sub>	-	0.4~4.0	-	-	V
Maximum Output Voltage Range	V <sub>OM+</sub>	I <sub>o</sub> =+250mA	4.55	4.65	-	V
	V <sub>OM-</sub>	I <sub>o</sub> = -250mA	-	0.35	0.45	V
Operating Current	I <sub>DD</sub>	-	-	3.0	4.0	mA
Feedback Resistance	R <sub>F</sub>	-	22.0	27.5	33.0	kΩ

(Note) The oscillation comes to happen easily in the state that there is no load of current and gain is low.  
In this case, please adjust the stray capacity of the output terminal to 100pF or less.

## APPLICATION CIRCUIT

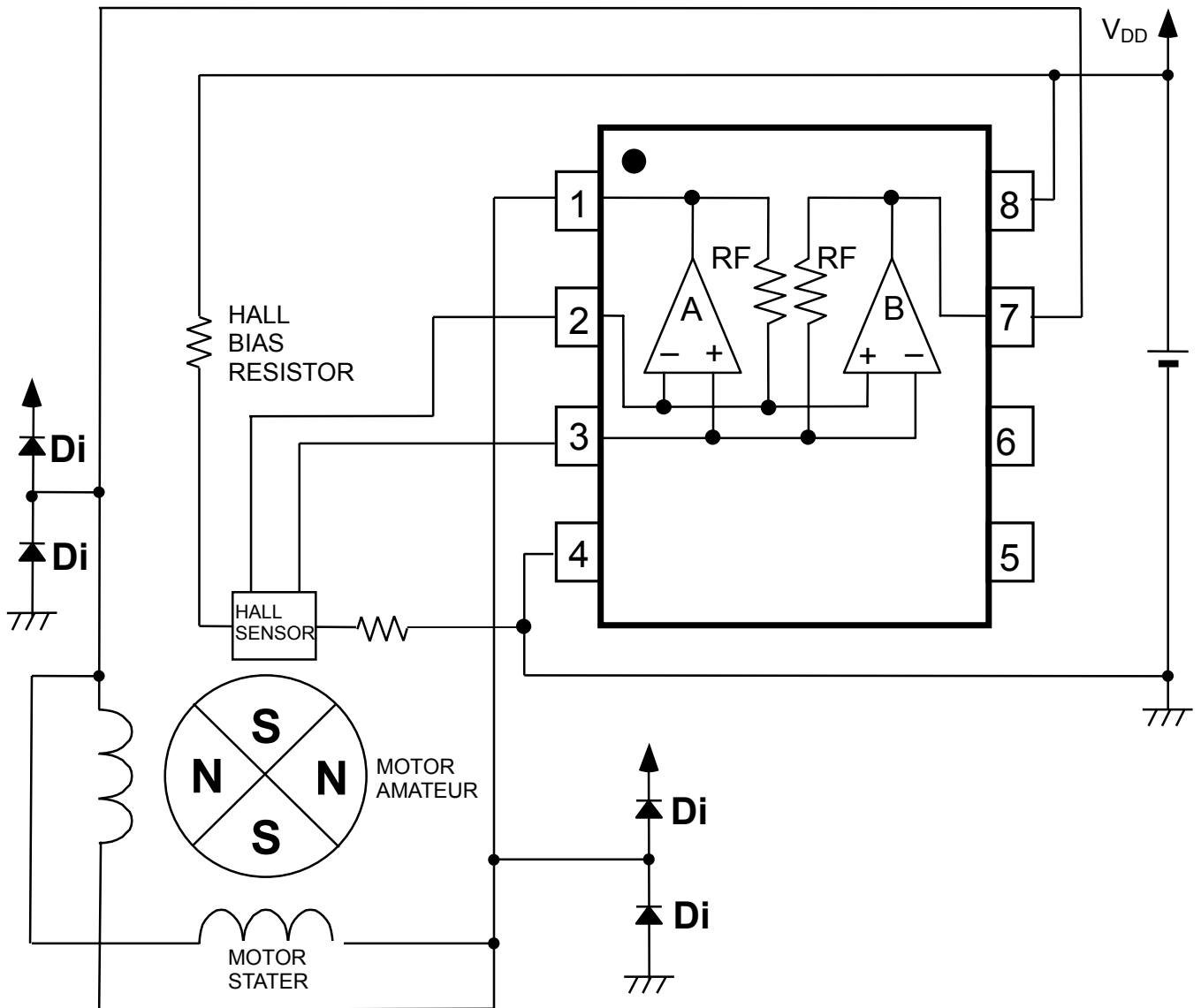

Diodes shown in the picture indicate external re-circulating diodes.  
Place re-circulating diodes at output terminal depending on the inductive load.

The specifications on this data book are only given for information, without any guarantee as regards either mistakes or omissions. The application circuit in this data book are described only to show representative usages of the product and not intended for the guarantee or permission of any right including the industrial rights.