

OCTAL BUFFER/LINE DRIVER; 3-STATE

FEATURES

- Non-inverting outputs
- Output capability: bus driver
- I_{CC} category: MSI

GENERAL DESCRIPTION

The 74HC/HCT541 are high-speed Si-gate CMOS devices and are pin compatible with low power Schottky TTL (LSTTL). They are specified in compliance with JEDEC standard no. 7A.

The 74HC/HCT541 are octal non-inverting buffer/line drivers with 3-state outputs. The 3-state outputs are controlled by the output enable inputs \overline{OE}_1 and \overline{OE}_2 .

A HIGH on \overline{OE}_n causes the outputs to assume a high impedance OFF-state.

The "541" is identical to the "540" but has non-inverting outputs.

SYMBOL	PARAMETER	CONDITIONS	TYPICAL		UNIT
			HC	HCT	
t_{PHL}/t_{PLH}	propagation delay A_n to Y_n	$C_L = 15$ pF $V_{CC} = 5$ V	10	12	ns
C_1	input capacitance		3.5	3.5	pF
CPD	power dissipation capacitance per buffer	notes 1 and 2	37	39	pF

GND = 0 V; $T_{amb} = 25$ °C; $t_r = t_f = 6$ ns

Notes

1. CPD is used to determine the dynamic power dissipation (P_D in μ W):

$$P_D = CPD \times V_{CC}^2 \times f_i + \Sigma (C_L \times V_{CC}^2 \times f_o) \text{ where:}$$

- f_i = input frequency in MHz
- f_o = output frequency in MHz
- $\Sigma (C_L \times V_{CC}^2 \times f_o)$ = sum of outputs
- C_L = output load capacitance in pF
- V_{CC} = supply voltage in V

2. For HC the condition is $V_I = \text{GND to } V_{CC}$
For HCT the condition is $V_I = \text{GND to } V_{CC} - 1.5$ V

PACKAGE OUTLINES

20-lead DIL; plastic (SOT146).
20-lead mini-pack; plastic (SO20; SOT163A).

PIN DESCRIPTION

PIN NO.	SYMBOL	NAME AND FUNCTION
1, 19	$\overline{OE}_1, \overline{OE}_2$	output enable input (active LOW)
2, 3, 4, 5, 6, 7, 8, 9	A_0 to A_7	data inputs
10	GND	ground (0 V)
18, 17, 16, 15, 14, 13, 12, 11	Y_0 to Y_7	bus outputs
20	V_{CC}	positive supply voltage

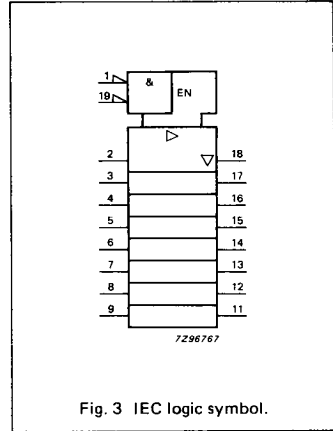
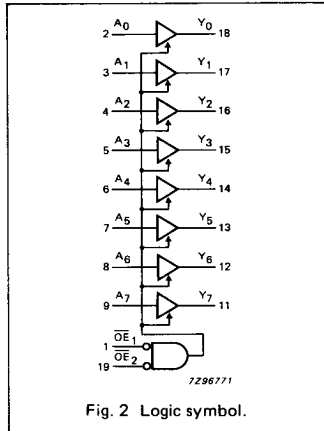
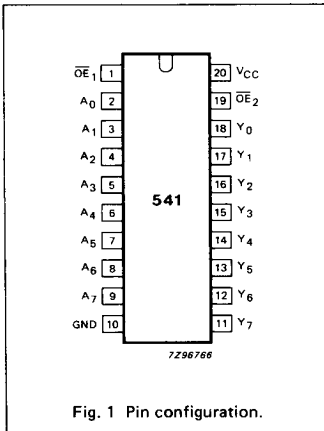

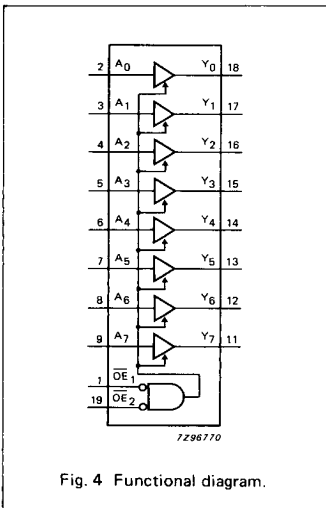

Fig. 4 Functional diagram.

FUNCTION TABLE

INPUTS			OUTPUT
\overline{OE}_1	\overline{OE}_2	A_n	Y_n
L	L	L	L
L	L	H	H
X	H	X	Z
H	X	X	Z

H = HIGH voltage level
L = LOW voltage level
X = don't care
Z = high impedance OFF-state

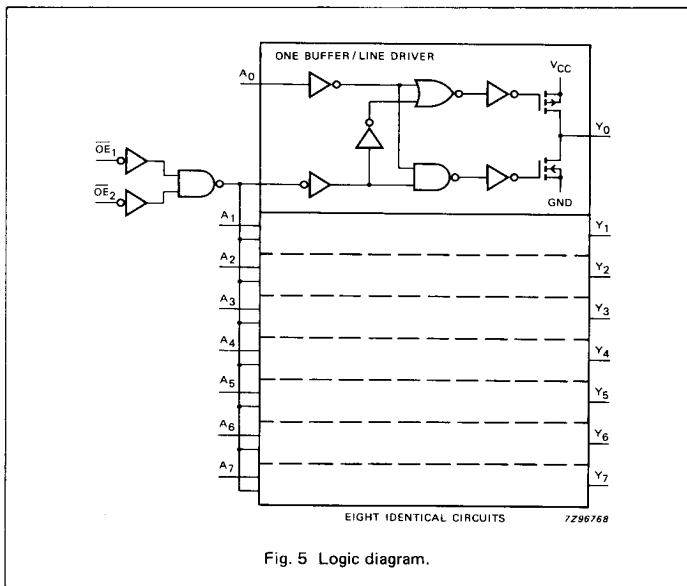

Fig. 5 Logic diagram.

DC CHARACTERISTICS FOR 74HC

For the DC characteristics see chapter "HCMOS family characteristics", section "Family specifications".

Output capability: bus driver

I_{CC} category: MSI**AC CHARACTERISTICS FOR 74HC**GND = 0 V; t_r = t_f = 6 ns; C_L = 50 pF

SYMBOL	PARAMETER	T _{amb} (°C)						UNIT	TEST CONDITIONS	
		74HC							V _{CC} V	WAVEFORMS
		+25			-40 to +85		-40 to +125			
		min.	typ.	max.	min.	max.	min.		max.	
t _{PHL} / t _{PLH}	propagation delay A _n to Y _n	33 12 10	115 23 20		145 29 25		175 35 30	ns	2.0 4.5 6.0	Fig. 6
t _{PZH} / t _{PZL}	3-state output enable time OE _n to Y _n	55 20 16	160 32 27		200 40 34		240 48 41	ns	2.0 4.5 6.0	Fig. 7
t _{PHZ} / t _{PLZ}	3-state output disable time OE _n to Y _n	61 22 18	160 32 27		200 40 34		240 48 41	ns	2.0 4.5 6.0	Fig. 7
t _{THL} / t _{TLH}	output transition time	14 5 4	60 12 10		75 15 13		90 18 15	ns	2.0 4.5 6.0	Fig. 6

DC CHARACTERISTICS FOR 74HCT

For the DC characteristics see chapter "HCMOS family characteristics", section "Family specifications".

Output capability: bus driver
I_{CC} category: MSI

Note to HCT types

The value of additional quiescent supply current (ΔI_{CC}) for a unit load of 1 is given in the family specifications. To determine ΔI_{CC} per input, multiply this value by the unit load coefficient shown in the table below.

INPUT	UNIT LOAD COEFFICIENT
\overline{OE}_1	1.50
\overline{OE}_2	1.00
A _n	0.70

AC CHARACTERISTICS FOR 74HCT

GND = 0 V; t_r = t_f = 6 ns; C_L = 50 pF

SYMBOL	PARAMETER	T _{amb} (°C)						UNIT	TEST CONDITIONS		
		74HCT							V _{CC} V	WAVEFORMS	
		+25			-40 to +85		-40 to +125				
		min.	typ.	max.	min.	max.	min.				max.
t _{PHL} / t _{PLH}	propagation delay A _n to Y _n		15	28		35		42	ns	4.5	Fig. 6
t _{PZH} / t _{PZL}	3-state output enable time \overline{OE}_n to Y _n		21	35		44		53	ns	4.5	Fig. 7
t _{PHZ} / t _{PLZ}	3-state output disable time \overline{OE}_n to Y _n		21	35		44		53	ns	4.5	Fig. 7
t _{THL} / t _{TLH}	output transition time		5	12		15		18	ns	4.5	Fig. 6

AC WAVEFORMS

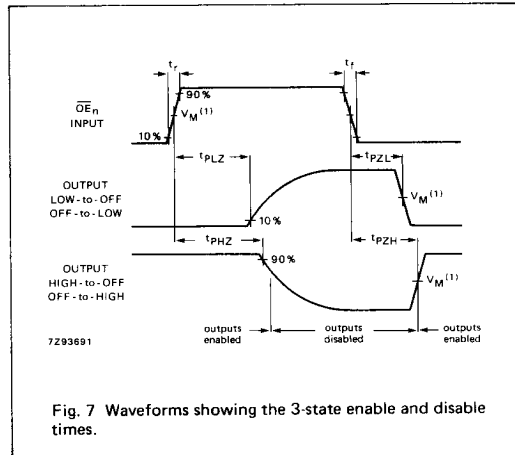
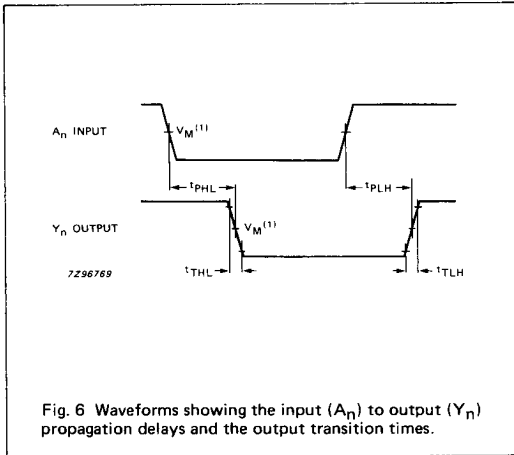

Note to AC waveforms

- (1) HC : $V_M = 50\%$; $V_I = \text{GND to } V_{CC}$.
- HCT: $V_M = 1.3 \text{ V}$; $V_I = \text{GND to } 3 \text{ V}$.