



RF Power Detectors in UCSP

MAX2205-MAX2208

General Description

The MAX2205-MAX2208 wideband (800MHz to 2GHz) power detectors are ideal for GSM/EDGE (MAX2206), TDMA (MAX2207), and CDMA (MAX2205/MAX2208) applications. The MAX2206/MAX2207/MAX2208 take an RF signal from a directional coupler at the input, and output a highly repeatable voltage. The output voltage increases monotonically with increasing input power. The output is compensated for temperature and process shifts, reducing the worst-case variation to less than $\pm 1\text{dB}$ at full power and $\pm 2.5\text{dB}$ at the lowest power.

The MAX2206 features 40dB dynamic range, making it ideally suited to GSM/EDGE applications. The MAX2207 offers reduced current consumption for TDMA applications. The MAX2205/MAX2208 each have an integrated filter to allow for average power detection of CDMA signals over a 25dB dynamic range. The MAX2206/MAX2207/MAX2208 offer internal 50Ω termination for interfacing with a directional coupler. The MAX2205 has a high-impedance input to provide a low-loss resistive tap in CDMA applications. All devices allow the user to control the averaging time constant externally. The MAX2205-MAX2208 come in a space-saving 2×2 , 0.5mm-pitch UCSP™ and require only three external components.

Applications

- Dual-Band GSM/EDGE Handsets
- Dual-Band CDMA/TDMA Handsets
- WCDMA Handsets
- PA Modules

Features

- ◆ **Space-Saving 2×2 UCSP Occupies Only 1mm^2**
- ◆ **Internal Temperature Compensation Gives $\pm 0.3\text{dB}$ Detection Accuracy**
- ◆ **No External Filter or Op Amp Required**
- ◆ **Power-Detection Range**
40dB (MAX2206)
25dB (MAX2205/MAX2207/2208)

Ordering Information

PART	TEMP RANGE	BUMP-PACKAGE
MAX2205EBS	-40°C to +85°C	2×2 UCSP*
MAX2206EBS	-40°C to +85°C	2×2 UCSP*
MAX2207EBS	-40°C to +85°C	2×2 UCSP*
MAX2208EBS	-40°C to +85°C	2×2 UCSP*

*Requires solder temperature profile described in the Absolute Maximum Ratings section.

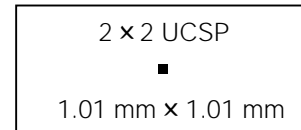

UCSP is a trademark of Maxim Integrated Products, Inc.

Pin Configuration/Functional Diagram/Typical Operating Circuit

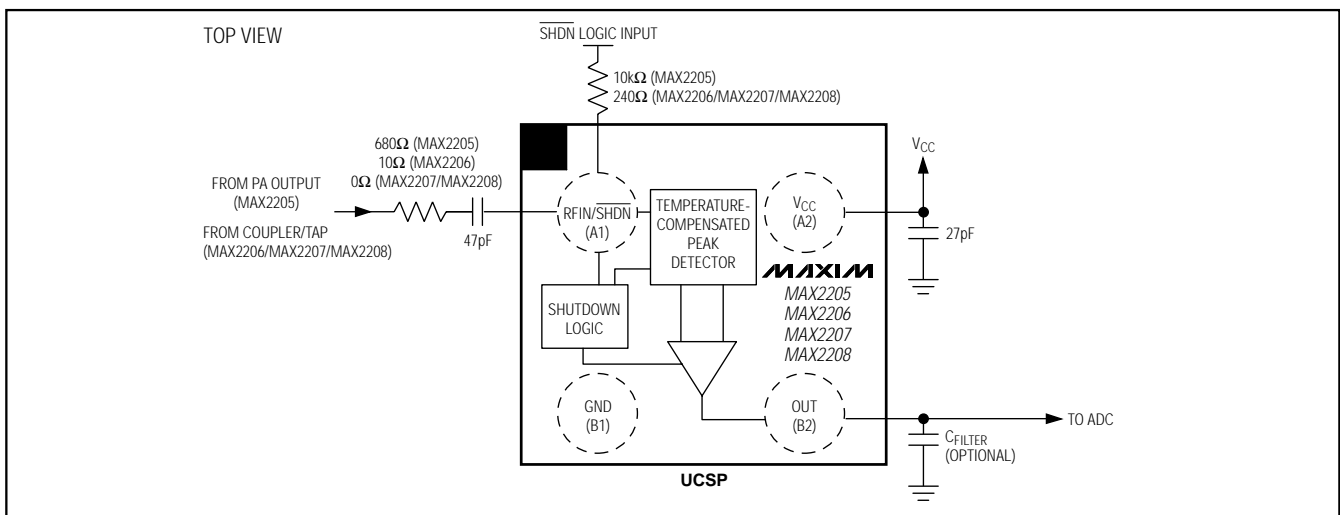

RF Power Detectors in UCSP

ABSOLUTE MAXIMUM RATINGS

V _{CC} to GND	-0.3V to +6.5V
RFIN/SHDN to GND	-0.3V to (V _{CC} + 0.3V)
RF Input Power (800MHz) (MAX2206/MAX2207/MAX2208)	+20dBm
RF Input Power (2GHz) (MAX2206/MAX2207/MAX2208)	+17dBm
RF Input Voltage (800MHz) (MAX2205)	1.5Vp
RF Input Voltage (2GHz) (MAX2205)	0.8Vp

Continuous Power Dissipation (T _A = +70°C) 2 × 2 UCSP (derate 3.8mW/°C above +70°C)	303mW
Operating Temperature Range	-40°C to +85°C
Junction Temperature	+150°C
Storage Temperature Range	-65°C to +160°C
Bump Temperature (soldering) (Note 1)	
Infrared (15s)	+220°C
Vapor Phase (60s)	+215°C

Stresses beyond those listed under "Absolute Maximum Ratings" may cause permanent damage to the device. These are stress ratings only, and functional operation of the device at these or any other conditions beyond those indicated in the operational sections of the specifications is not implied. Exposure to absolute maximum rating conditions for extended periods may affect device reliability.

DC ELECTRICAL CHARACTERISTICS (MAX2205-MAX2208)

(V_{CC} = +2.7V to +5.0V, $\overline{\text{SHDN}}$ = +2.0V, no RF signal applied, T_A = -40°C to +85°C. Typical values are at V_{CC} = +2.85V and T_A = +25°C, unless otherwise noted.) (Note 2)

PARAMETER	SYMBOL	CONDITIONS	MIN	TYP	MAX	UNITS
Supply Voltage	V _{CC}		2.7		5.0	V
Idle Supply Current	I _{IDLE}	MAX2206		3.5	5.5	mA
		MAX2205/MAX2207/MAX2208		2	3.5	
Shutdown Supply Current	I _{SHDN}	$\overline{\text{SHDN}} = 0\text{V}$		0.5	10	μA
OUT Voltage During Shutdown	V _{OUT}	$\overline{\text{SHDN}} = 0\text{V}$			0.01	V
Logic-High Threshold	V _H		2.0			V
Logic-Low Threshold	V _L				0.6	V
$\overline{\text{SHDN}}$ Input Current	I _{IH}	$\overline{\text{SHDN}} = +2.0\text{V}$	-1		+10	μA
	I _{IL}	$\overline{\text{SHDN}} = +0.6\text{V}$	-1		+1	
Output Current Source Capability		MAX2206/MAX2207, V _{OUT} = +2.5V	400			μA
Output Current Sink Capability		MAX2206/MAX2207, V _{OUT} = 0V	300			μA

AC ELECTRICAL CHARACTERISTICS (MAX2205)

(MAX2205 EV kit, V_{CC} = +2.7V to +5.0V, $\overline{\text{SHDN}}$ = +2.0V, f_{RF} = 800MHz to 2GHz, 50Ω system, T_A = -40°C to +85°C. Typical values are at V_{CC} = +2.85V and T_A = +25°C, unless otherwise noted.) (Note 2)

PARAMETER	SYMBOL	CONDITIONS	MIN	TYP	MAX	UNITS	
RF Input Frequency	f _{RF}		800		2000	MHz	
Turn-On Time	t _{ON}			2		μs	
Response Time	t _R	(Note 3)		15		μs	
Variation Due to Temperature		V _{CC} = +2.85V, T _A = -40°C to +85°C	High input power (Note 4)		±0.3	±1	dB
			Low input power (Note 5)		±1.3	±2.5	

RF Power Detectors in UCSP

MAX2205-MAX2208

AC ELECTRICAL CHARACTERISTICS (MAX2206/MAX2207/MAX2208)

(MAX2206/MAX2207/MAX2208 EV kit, $V_{CC} = +2.7V$ to $+5.0V$, $\overline{SHDN} = 2.0V$, $f_{RF} = 800MHz$ to $2GHz$, 50Ω system, $T_A = -40^\circ C$ to $+85^\circ C$. Typical values are at $V_{CC} = +2.85V$ and $T_A = +25^\circ C$, unless otherwise noted.) (Note 2)

PARAMETER	SYMBOL	CONDITIONS		MIN	TYP	MAX	UNITS
RF Input Frequency	f_{RF}			800		2000	MHz
RF Input VSWR	VSWR				2:1		
Turn-On Time	t_{ON}				2		μs
Response Time (Note 3)	t_R	MAX2206/MAX2207			300		μs
		MAX2208			15		
Variation Due to Temperature		$V_{CC} = +2.85V$, $T_A = -40^\circ C$ to $+85^\circ C$	High input power (Note 6)	± 0.3	± 1		dB
			Low input power (Note 7)	± 1.3	± 2.5		

- Note 1:** This device is constructed using a unique set of packaging techniques that imposes a limit on the thermal profile the device can be exposed to during board-level solder attach and rework. This limit permits only the use of the solder profiles recommended in the industry-standard specification, JEDEC 020A, paragraph 7.6, Table 3 for IR/VPR and convection reflow. Preheating is required. Hand or wave soldering is not allowed.
- Note 2:** Specifications over $T_A = -40^\circ C$ to $+85^\circ C$ are guaranteed by design. Production tests are performed at $T_A = +25^\circ C$.
- Note 3:** Response time is taken from the time the RF signal is applied to 90% of the final value of V_{OUT} .
- Note 4:** At 800MHz, output voltage is held at a value that nominally results from the final value of $+31dBm$ input power. Deviation from $+31dBm$ is specified. At 2GHz, output voltage is held at a value that nominally results from $+28dBm$ input power. Deviation from $+28dBm$ is specified.
- Note 5:** At 2GHz, output voltage is held 22dB lower than specified in Note 4. At 800MHz, output voltage is held 25dB lower than specified in Note 4.
- Note 6:** At 800MHz, output voltage is held at a value that nominally results from $+15dBm$ input power. Deviation from $+15dBm$ is specified. At 2GHz, output voltage is held at a value that nominally results from $+13dBm$ input power. Deviation from $+13dBm$ is specified.
- Note 7:** For MAX2206, output voltage is held 40dB lower than specified in Note 7; for MAX2207/MAX2208, output voltage is held 25dB lower than specified in Note 7.

Typical Operating Characteristics

(MAX2206/MAX2207/MAX2208 EV kit, $T_A = +25^\circ C$, unless otherwise noted.)

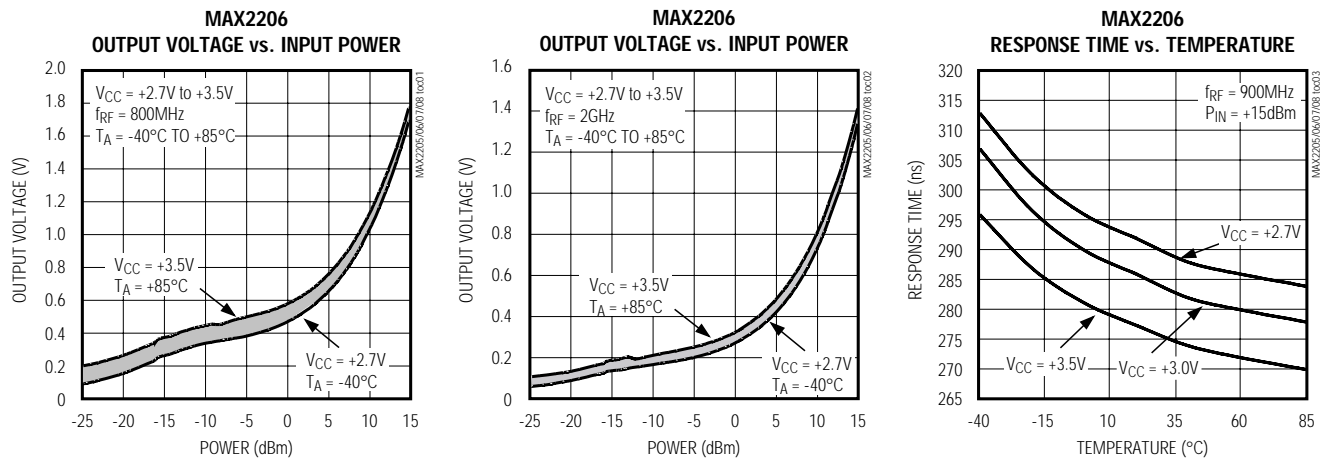

RF Power Detectors in UCSP

Typical Operating Characteristics (continued)

(MAX2206/MAX2207/MAX2208 EV kit, $T_A = +25^\circ\text{C}$, unless otherwise noted.)

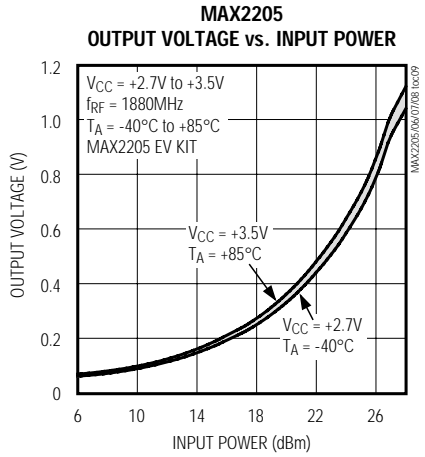
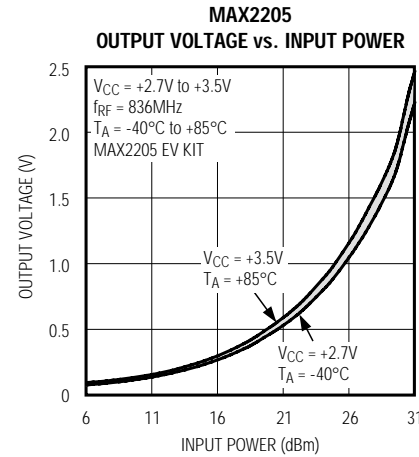
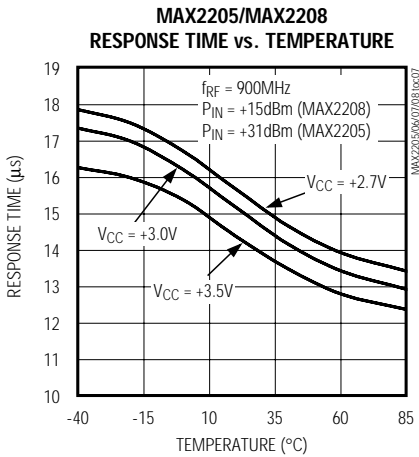
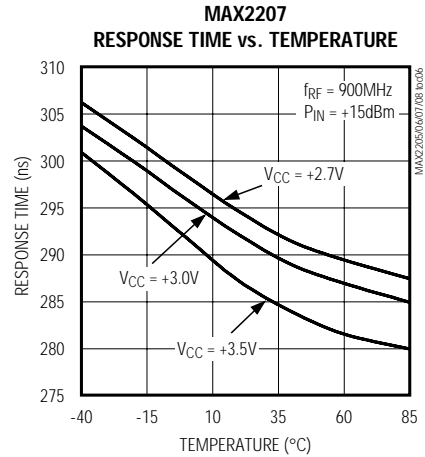
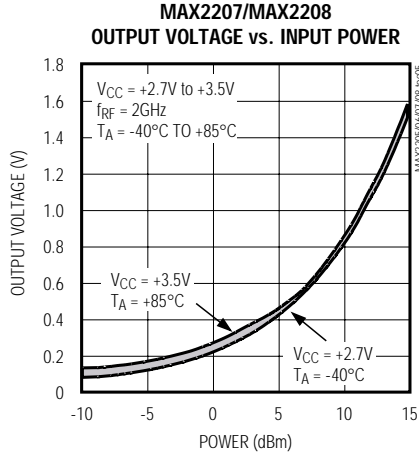
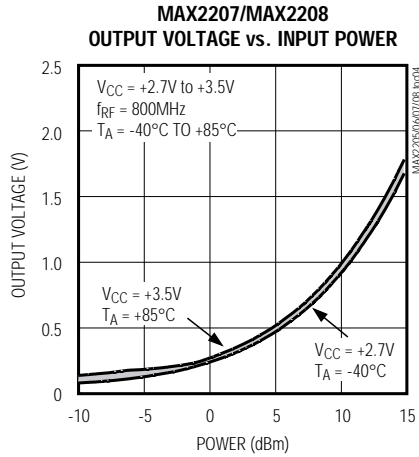

Pin Description

PIN	NAME	FUNCTION
A1	RFIN/ $\overline{\text{SHDN}}$	RF Input and Shutdown Logic Input. AC-couple the RF input to this pin and apply the shutdown logic input through a resistor. Drive low to turn the part off, drive high, or connect to V_{CC} to turn the part on.
A2	V_{CC}	Power-Supply Pin. Bypass to GND with a capacitor as close to the bump as possible.
B1	GND	Ground Connection. Multiple ground vias placed as close to the IC as possible should be used to connect the ground pin to the ground plane. Connect to PC board ground plane with as low inductance as possible.
B2	OUT	Detector Output

RF Power Detectors in UCSP

MAX2205-MAX2208

Applications Information

The MAX2205–MAX2208 have internal termination resistors for use with directional couplers. The application circuit is shown in Figure 1. The output of the detector goes to an op amp in an analog GSM power-control scheme, or to an ADC in other systems such as TDMA or discrete-time GSM power control.

The MAX2205 has high-input impedance for use with high-value resistive tapping from a CDMA power amplifier. This coupling method is the lowest cost and lowest loss when used with an isolator. The application circuit is shown in Figure 2. Connect C_{FILTER} from the MAX2205 output to GND to reduce residual amplitude ripple. For IS98A reverse channel signal with peak-to-avg ratio of 3.9dB, a 1.5nF capacitor gives 43mV_{p-p} ripple at 28dBm PA output and 390μs response time. For CDMA2000 (pilot + DCCH) with peak-to-avg ratio of 5.4dB, the ripple is about 65mV_{p-p} at 26dBm PA output.

The MAX2205 input impedance is listed in Table 1.

Layout

As with any RF circuit, the layout of the MAX2205–MAX2208 circuits affects performance. Use a short 50Ω line at the input with multiple ground vias along the length of the line. The input capacitor and resistor should be placed as close to the IC as possible. The V_{CC} input should be bypassed as close as possible to the IC with multiple vias connecting the capacitor to ground. Refer to the MAX2205–MAX2208 EV kit data sheet for a sample layout and details.

UCSP Reliability

The UCSP is a unique package that greatly reduces board space compared to other packages. UCSP reliability is integrally linked to the user's assembly methods, circuit board material, and usage environment. The user should closely review these areas when considering using a UCSP. This form factor might not perform equally to a packaged product through traditional mechanical reliability tests. Performance through operating life test and moisture resistance remains uncompromised, as it is determined primarily by the wafer-fabrication process.

Mechanical stress performance is a greater consideration for a UCSP. UCSP solder-joint contact integrity must be considered because the package is attached through direct solder contact to the user's PC board. Testing done to characterize the UCSP reliability performance shows that it is capable of performing reliably through environmental stresses. Results of environmental stress tests and additional usage data and recommendations are detailed in the UCSP application note, which can be found on Maxim's website, www.maxim-ic.com.

Chip Information

TRANSISTOR COUNT: 344

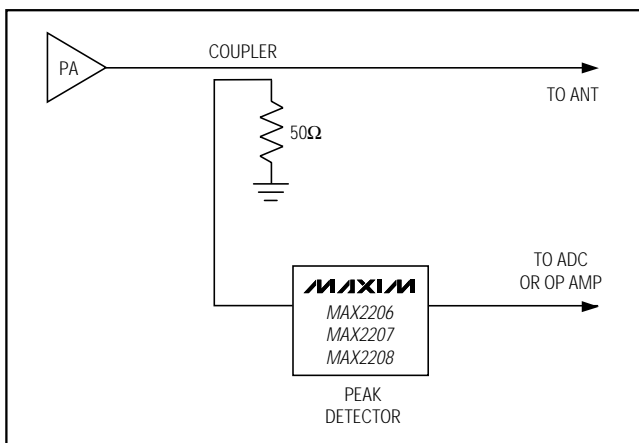

Figure 1. MAX2206/MAX2207/MAX2208 Typical Application Circuit

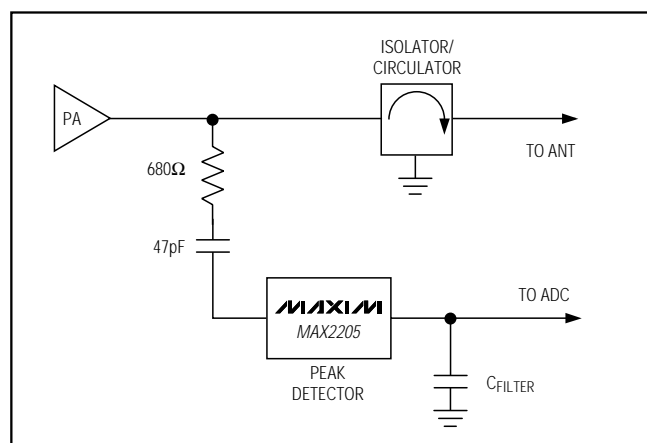

Figure 2. MAX2205 Typical Application Circuit

RF Power Detectors in UCSP

MAX2205-MAX2208

Table 1. MAX2205 Input Impedance (R || jX, PC Board De-Embedded)

FREQUENCY (GHz)	P _{IN} = -30dBm		P _{IN} = +5dBm	
	REAL	IMAG	REAL	IMAG
0.8	189.9	-51.7	199.4	-54.0
0.9	177.3	-47.4	185.5	-49.4
1.0	165.8	-43.6	175.2	-45.7
1.1	155.2	-40.3	167.0	-42.5
1.2	146.4	-37.6	158.8	-39.8
1.3	138.8	-35.0	150.9	-37.3
1.4	131.5	-32.9	144.0	-35.1
1.5	123.3	-30.7	139.4	-33.3
1.6	115.0	-29.1	131.6	-31.8
1.7	107.2	-27.5	132.0	-30.9
1.8	110.7	-26.7	126.6	-29.3
1.9	105.3	-25.2	120.3	-27.9
2.0	94.7	-23.6	111.4	-26.7

Table 2. MAX2205-MAX2208 Device Marking Codes

DEVICE	CODE
MAX2205EBS	AFR
MAX2206EBS	AFO
MAX2207EBS	AFP
MAX2208EBS	AFQ

RF Power Detectors in UCSP

Package Information

(The package drawing(s) in this data sheet may not reflect the most current specifications. For the latest package outline information, go to www.maxim-ic.com/packages.)

MAX2205-MAX2208

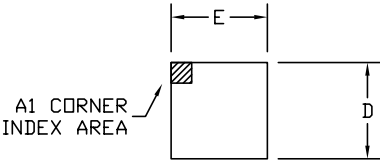

TOP VIEW

SYMBOL	DIMENSIONS
A	0.60±0.05
D	1.02±0.05
E	1.02±0.05
e	0.50 BASIC
b	∅ 0.35 BASIC
A1	0.27±0.04
A2	0.33 Ref.
hd	0.26 Ref.
he	0.26 Ref.

SOLDER BALL DEPOPULATION	
PKG. CODE	DEPOPULATED BALL
B4-1	NONE

NOTES:
 1. ALL DIMENSIONS ARE IN MILLIMETERS.
 2. MEETS JEDEC M0195.

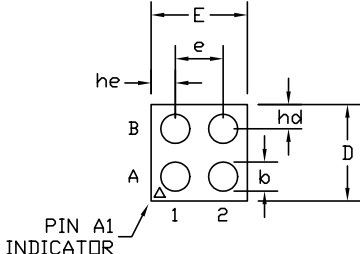

BOTTOM VIEW

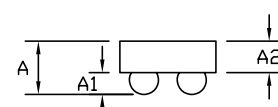

SIDE VIEW



PROPRIETARY INFORMATION

TITLE: PACKAGE OUTLINE, 2x2 UCSP

APPROVAL	DOCUMENT CONTROL NO. 21-0117	REV. B	1/1
----------	---------------------------------	-----------	-----

4L, UCSP 2x2 EPS

Maxim cannot assume responsibility for use of any circuitry other than circuitry entirely embodied in a Maxim product. No circuit patent licenses are implied. Maxim reserves the right to change the circuitry and specifications without notice at any time.