

TOSHIBA TRANSISTOR SILICON NPN EPITAXIAL TYPE (PCT PROCESS)

RN1414, RN1415, RN1416, RN1417, RN1418

SWITCHING, INVERTER CIRCUIT, INTERFACE CIRCUIT
AND DRIVER CIRCUIT APPLICATIONS.

Unit in mm

- With Built-in Bias Resistors
- Simplify Circuit Design
- Reduce a Quantity of Parts and Manufacturing Process
- Complementary to RN2414~RN2418

EQUIVALENT CIRCUIT AND BIAS RESISTOR VALUES

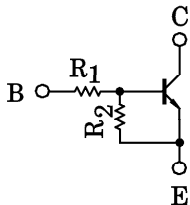

TYPE No.	R ₁ (kΩ)	R ₂ (kΩ)
RN1414	1	10
RN1415	2.2	10
RN1416	4.7	10
RN1417	10	4.7
RN1418	47	10

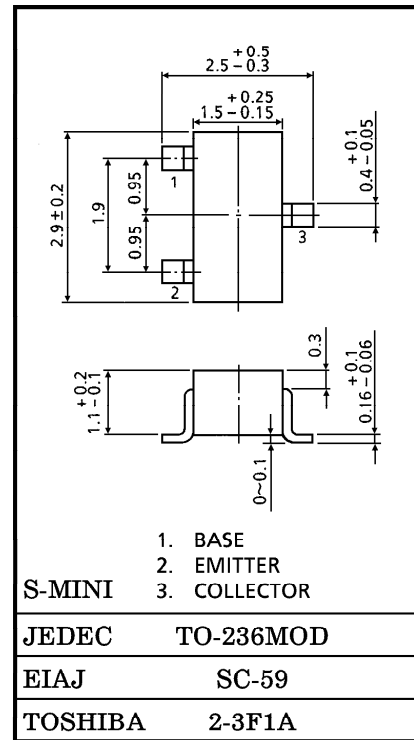

Weight : 0.012g

MAXIMUM RATINGS (Ta = 25°C)

CHARACTERISTIC		SYMBOL	RATING	UNIT
Collector-Base Voltage	RN1414~1418	V _{CB0}	50	V
Collector-Emitter Voltage		V _{CE0}	50	V
Emitter-Base Voltage	RN1414	V _{EB0}	5	V
	RN1415		6	
	RN1416		7	
	RN1417		15	
	RN1418		25	
Collector Current	RN1414~1418	I _C	100	mA
Collector Power Dissipation		P _C	200	mW
Junction Temperature		T _j	150	°C
Storage Temperature Range		T _{stg}	-55~150	°C

961001EAA2

● TOSHIBA is continually working to improve the quality and the reliability of its products. Nevertheless, semiconductor devices in general can malfunction or fail due to their inherent electrical sensitivity and vulnerability to physical stress. It is the responsibility of the buyer, when utilizing TOSHIBA products, to observe standards of safety, and to avoid situations in which a malfunction or failure of a TOSHIBA product could cause loss of human life, bodily injury or damage to property. In developing your designs, please ensure that TOSHIBA products are used within specified operating ranges as set forth in the most recent products specifications. Also, please keep in mind the precautions and conditions set forth in the TOSHIBA Semiconductor Reliability Handbook.

● The information contained herein is presented only as a guide for the applications of our products. No responsibility is assumed by TOSHIBA CORPORATION for any infringements of intellectual property or other rights of the third parties which may result from its use. No license is granted by implication or otherwise under any intellectual property or other rights of TOSHIBA CORPORATION or others.

● The information contained herein is subject to change without notice.

ELECTRICAL CHARACTERISTICS (Ta = 25°C)

CHARACTERISTIC		SYMBOL	TEST CONDITION	MIN.	TYP.	MAX.	UNIT
Collector Cut-off Current	RN1414~1418	I_{CBO}	$V_{CB}=50V, I_E=0$	—	—	100	nA
	RN1414~1418	I_{CEO}	$V_{CE}=50V, I_B=0$	—	—	500	nA
Emitter Cut-off Current	RN1414	I_{EBO}	$V_{EB}=5V, I_C=0$	0.35	—	0.65	mA
	RN1415		$V_{EB}=6V, I_C=0$	0.37	—	0.71	
	RN1416		$V_{EB}=7V, I_C=0$	0.36	—	0.68	
	RN1417		$V_{EB}=15V, I_C=0$	0.78	—	1.46	
	RN1418		$V_{EB}=25V, I_C=0$	0.33	—	0.63	
DC Current Gain	RN1414~16, 18	h_{FE}	$V_{CE}=5V, I_C=10mA$	50	—	—	
	RN1417			30	—	—	
Collector-Emitter Saturation Voltage	RN1414~1418	$V_{CE(sat)}$	$I_C=5mA, I_B=0.25mA$	—	0.1	0.3	V
Input Voltage (ON)	RN1414	$V_{I(ON)}$	$V_{CE}=0.2V, I_C=5mA$	0.6	—	2.0	V
	RN1415			0.7	—	2.5	
	RN1416			0.8	—	2.5	
	RN1417			1.5	—	3.5	
	RN1418			2.5	—	10.0	
Input Voltage (OFF)	RN1414	$V_{I(OFF)}$	$V_{CE}=5V, I_C=0.1mA$	0.3	—	0.9	V
	RN1415			0.3	—	1.0	
	RN1416			0.3	—	1.1	
	RN1417			0.3	—	2.3	
	RN1418			0.5	—	5.7	
Transition Frequency	RN1414~1418	f_T	$V_{CE}=10V, I_C=5mA$	—	250	—	MHz
Collector Output Capacitance	RN1414~1418	C_{ob}	$V_{CB}=10V, I_E=0, f=1MHz$	—	3.0	6.0	pF
Input Resistor	RN1414	R_1	—	0.7	1.0	1.3	kΩ
	RN1415			1.54	2.2	2.86	
	RN1416			3.29	4.7	6.11	
	RN1417			7.0	10.0	13.0	
	RN1418			32.9	47.0	61.1	
Resistor Ratio	RN1414	R_1/R_2	—	—	0.1	—	
	RN1415			—	0.22	—	
	RN1416			—	0.47	—	
	RN1417			—	2.13	—	
	RN1418			—	4.7	—	

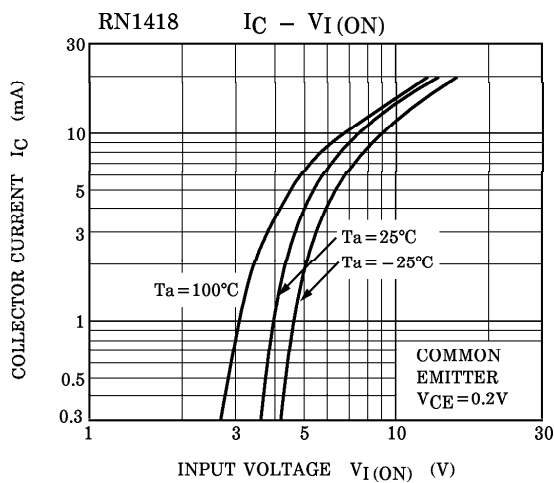
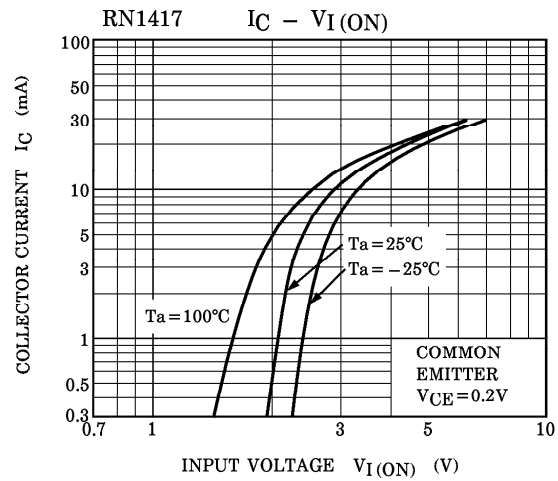
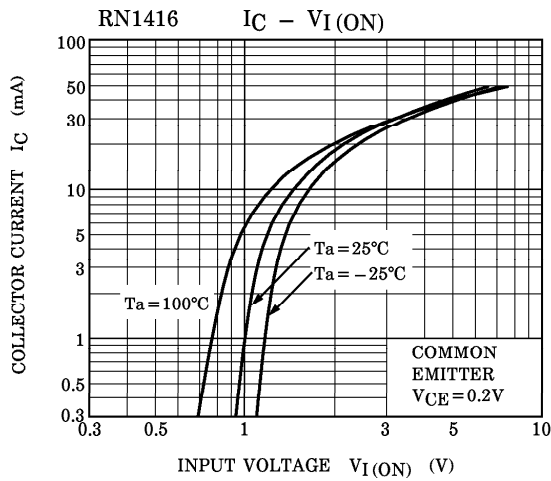
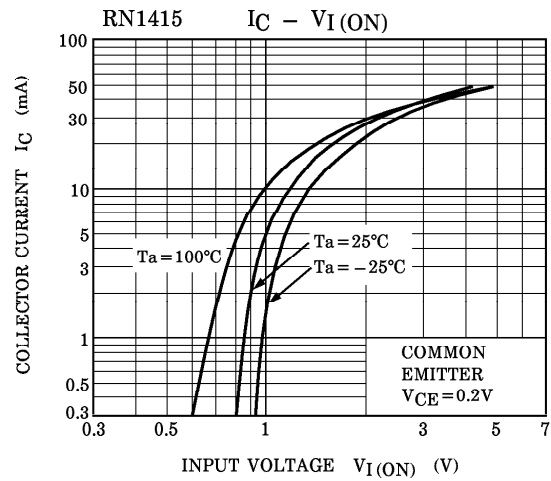
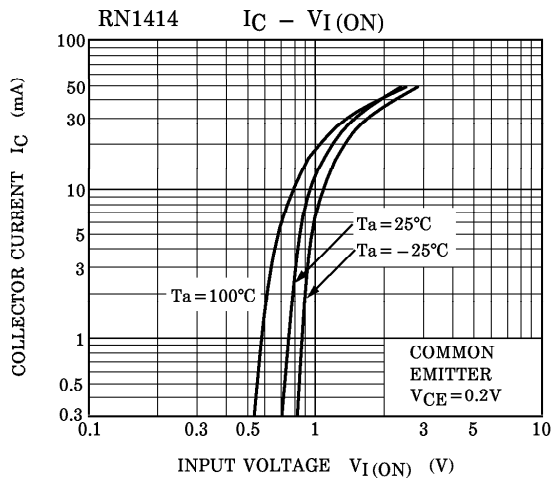

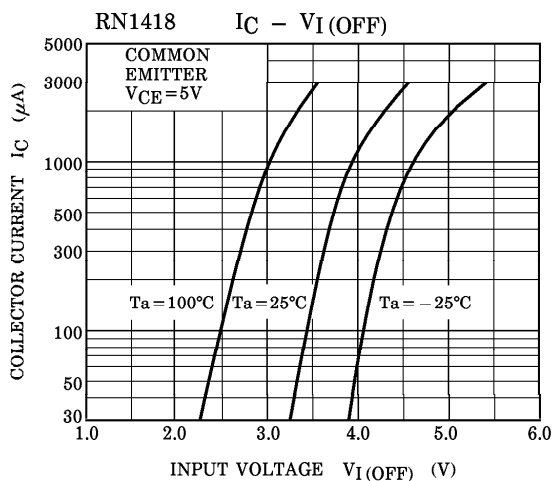
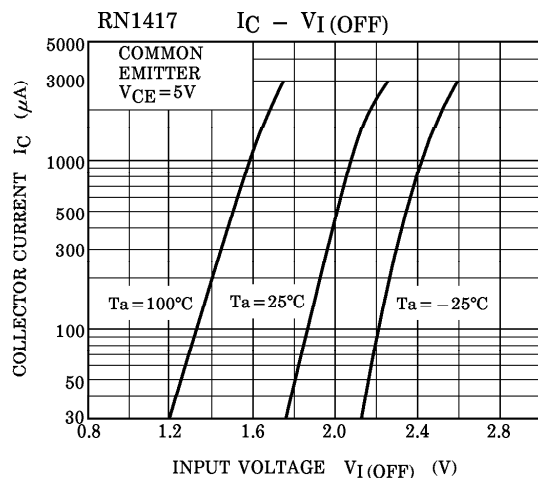
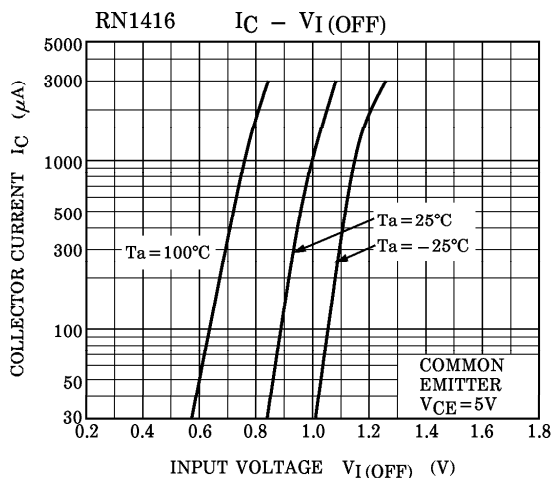
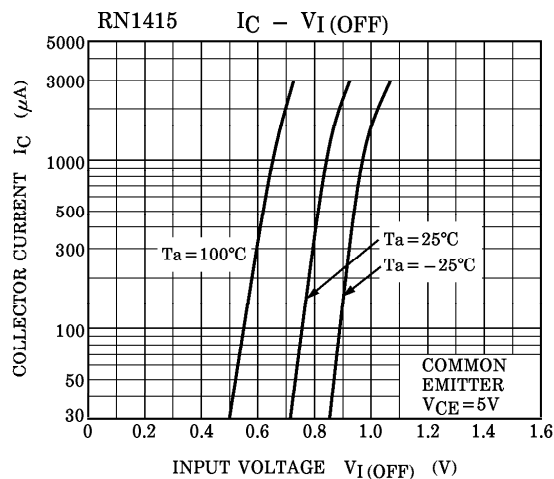
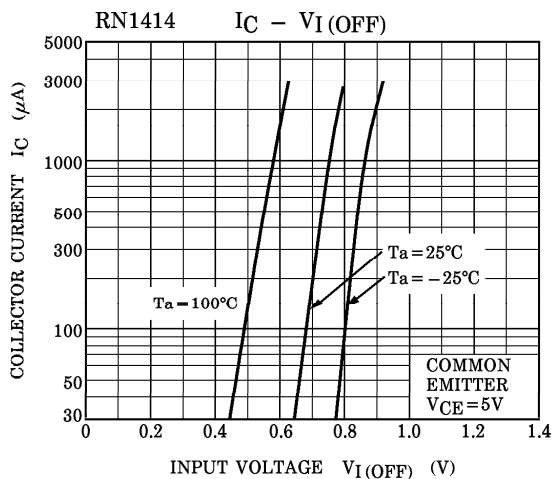

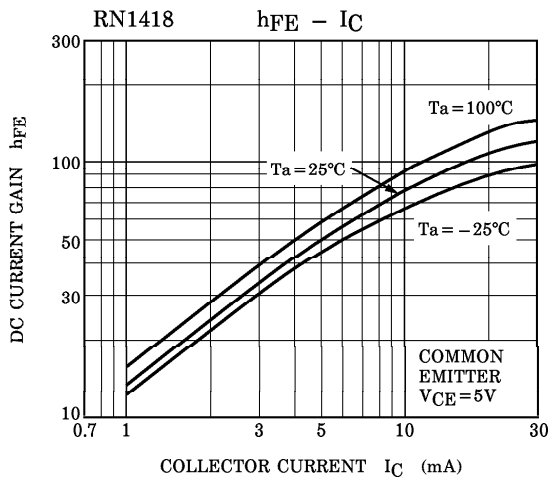
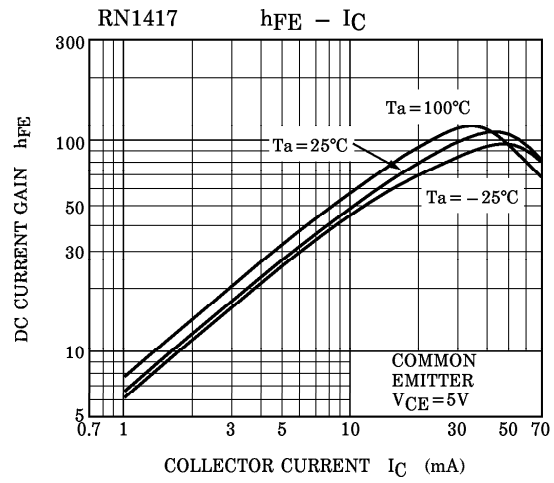
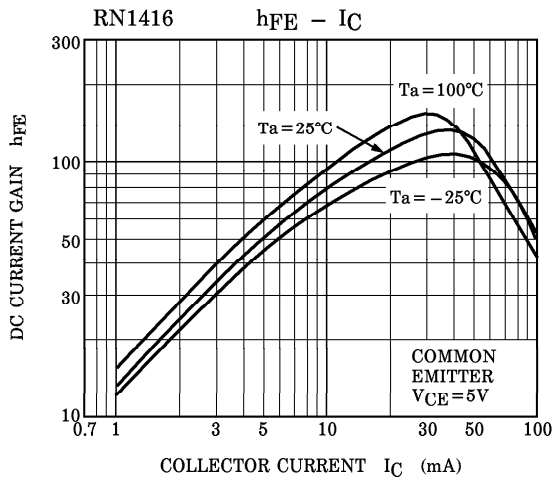
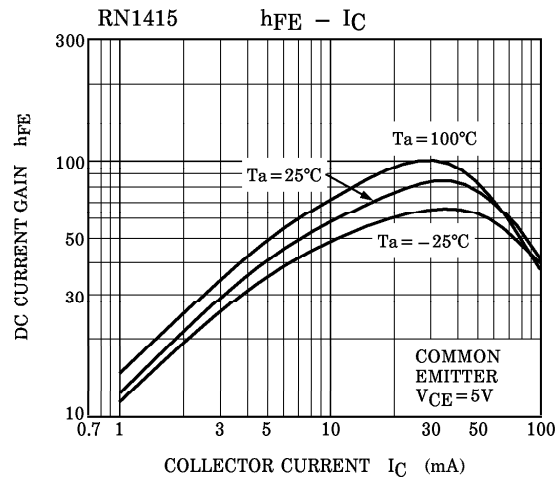
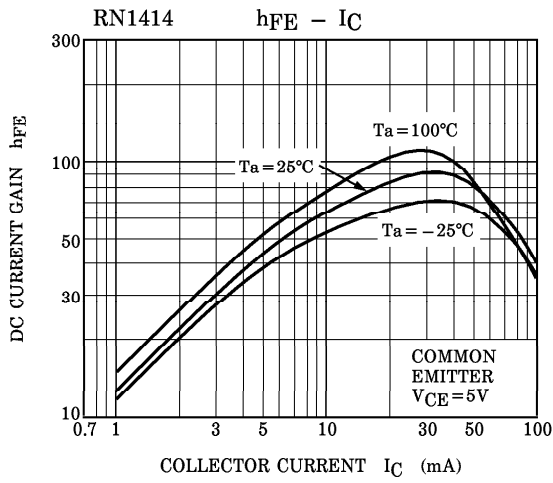

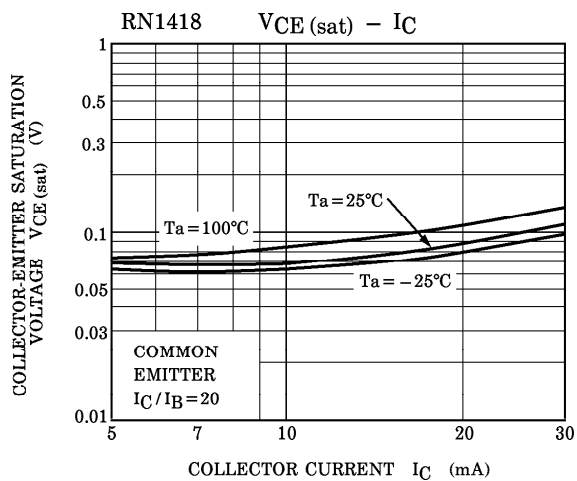
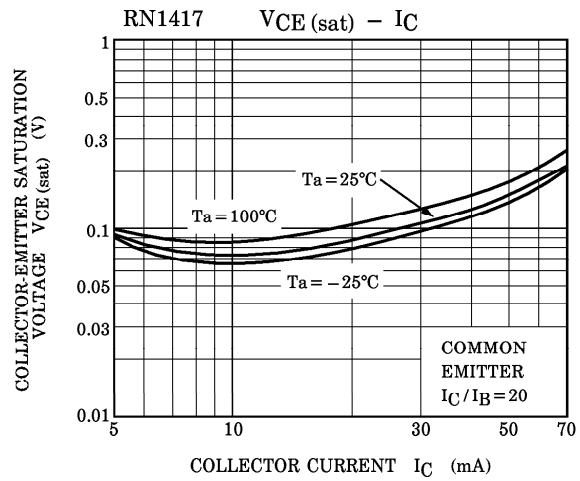
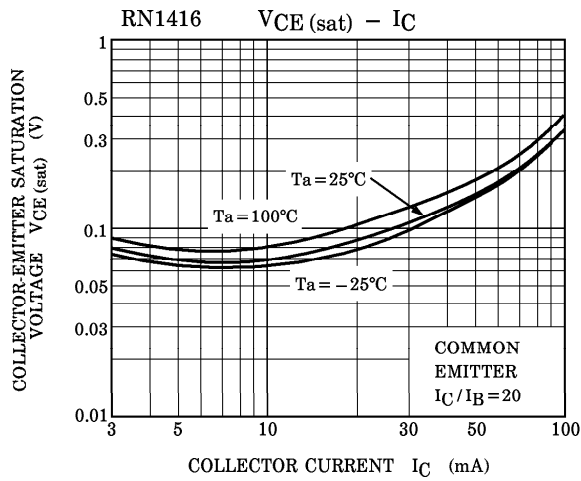
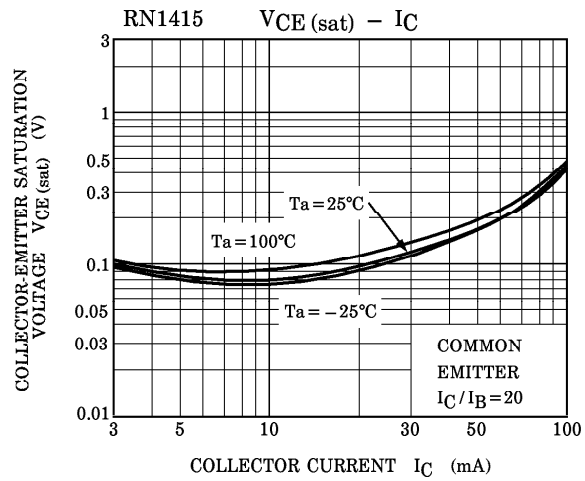
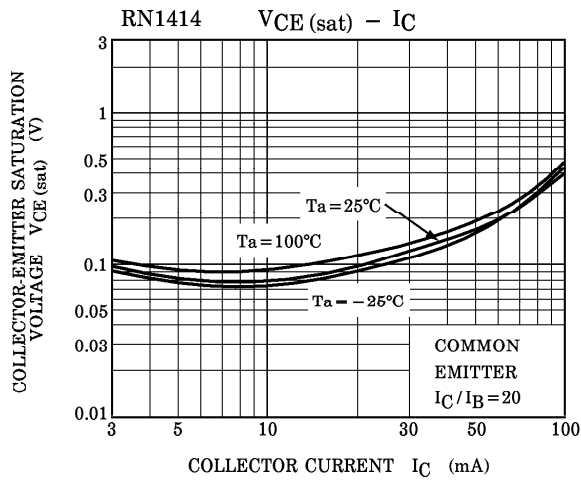

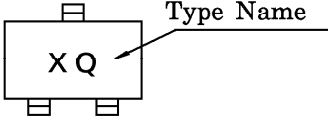
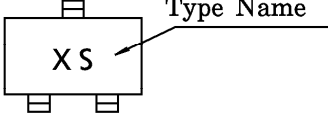
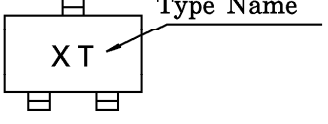
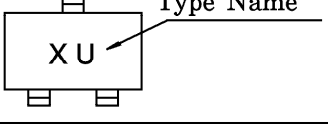
TYPE NAME	MARKING
RN1414	
RN1415	
RN1416	
RN1417	
RN1418	