



Details are subject to change without notice.

ADJUSTABLE TRIPLE-CHANNEL TFT LCD DC-DC CONVERTER

Features

- Built in 1.6A, 0.2Ω Switching NMOS
- Fault and Thermal Protection
- Internal Soft-Start Function
- Internal Power Up Sequencing
- Dual Adjustable Charge Pump Output
Positive Output to 40V
Negative Output to -40V
- Power Good Output
- TSSOP-16 Package

Pin Configuration

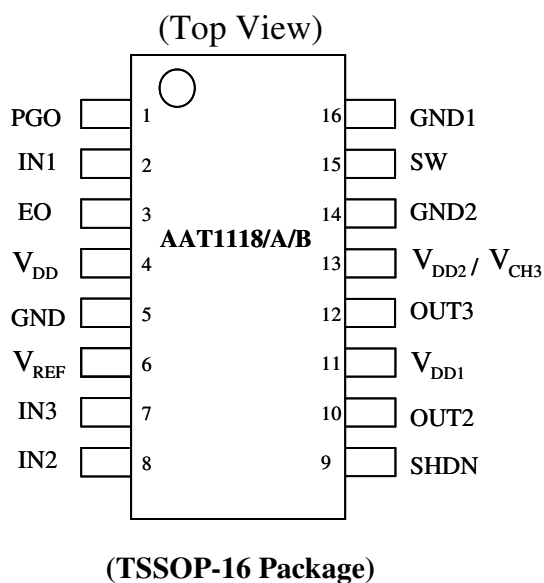

General Description

The AAT1118/A/B is an adjustable triple-channel TFT LCD DC-DC converter that provides one current mode PWM, one positive charge pump and one negative charge pump. Built-in functions include soft-start and power up sequencing. When power is turned on, soft-start avoids inrush current. Power up sequencing feature provides compensation for LCD panel to maintain a smooth voltage during a turn-on cycle.

The DC-DC converter consists of an on-chip voltage reference, error amplifier, current sense, pulse width modulation controller, under-voltage lockout protection, thermal detect, soft-start, and fault protection circuit.

When the two charge pumps are in operation, the output voltage would be doubled and the generated VP3 and VP2 (Note 1) could switch on or off TFT gate.

With the minimal external components, the AAT1118/A/B offers a simple and economical solution for TFT LCD power.

Note 1: Please refer to page 13 and 14 for VP3 and VP2.



Pin Description

PIN NO.	NAME	I/O	DESCRIPTION
1	PGO	O	HV Switch Output
2	IN1	I	Inverting Input Pin of PWM Error Amplifier
3	EO	I	Output Pin of PWM Error Amplifier
4	V _{DD}	-	Power Supply
5	GND	-	Ground
6	V _{REF}	O	Reference Voltage Output
7	IN3	I	Charge Pump Channel 3 Feedback Input
8	IN2	I	Charge Pump Channel 2 Feedback Input
9	SHDN	I	Shutdown Control Pin; High for Enable
10	OUT2	O	Charge Pump Channel 2 Output
11	V _{DD1}	-	High Voltage Power Supply
12	OUT3	O	Charge Pump Channel 3 Output
13	V _{DD2}	-	High Voltage Power Supply
	V _{CH3}	O	Power Output for Channel 3 (AAT1118B Only)
14	GND2	-	Ground
15	SW	O	Switch Pin
16	GND1	-	SW MOS Ground

**Absolute Maximum Ratings**

PARAMETER	SYMBOL	VALUE	UNIT
V_{DD} to GND	V_{DD}	7	V
SW to GND	V_{SW}	18	V
V_{DD1} , V_{DD2} to GND	V_{DDH}	16	V
Input Voltage 1 (IN1, IN2, IN3, SHDN)	V_{I1}	$V_{DD} + 0.3$	V
Output Voltage 1 (EO, V_{REF})	V_{O1}	$V_{DD} + 0.3$	V
Output Voltage 2 (OUT2, OUT3, SW, PGO)	V_{O2}	$V_{DDH} + 0.3$	V
Operating Free-Air Temperature Range	T_C	-40 to +85	°C
Storage Temperature Range	$T_{storage}$	-45 to +125	°C
Power Dissipation	P_d	750	mW



Electrical Characteristics, $V_{DD}= 3.3V$, $V_{DDH}= 10V$

Operating Power

PARAMETER	SYMBOL	TEST CONDITION	MIN	TYP	MAX	UNIT
Input Supply Voltage Range	V_{DD}		2.6		5.5	V
VDD Under Voltage Lockout	V_{UVLO}	Falling	2.1	2.2	2.3	V
		Rising	2.3	2.4	2.5	V
Regulated Output Voltage Range	V_{PI}		6		14	V
Quiescent Current	I_{VDD}	$V_{IN1}=1.3V$, not switching		0.5	0.8	mA
		$V_{IN1}=1.1V$, switching		3	6	mA
Shutdown Current	I_{SHDN}	$V_{SHDN}=GND$		0.1	10.0	μA
Thermal Shutdown				160		$^{\circ}C$

Reference Voltage

PARAMETER	SYMBOL	TEST CONDITION	MIN	TYP	MAX	UNIT
Reference Voltage	V_{REF}	$I_{Vref} = 100\mu A$	1.238	1.250	1.262	V
Line Regulation	V_{RI}	$I_{Vref} = 100\mu A$, $V_{DD}=2.5V\sim 5V$	-	2	5	mV
Load Regulation	V_{RO}	$I_{Vref} = 0\sim 100\mu A$	-	1	5	mV

EA (Error Amplifier)

PARAMETER	SYMBOL	TEST CONDITION	MIN	TYP	MAX	UNIT
Feedback Voltage	V_{IN1}	Level to produce $V_{EO}=1.24V$	1.238	1.250	1.262	V
Input Bias Current	I_{B1}	$V_{IN1}=1.24V$		0	40	nA
Feedback-Voltage Line Regulation	V_{RI}	Level to produce $V_{EO} = 1.24V$ $2.6V < V_{DD} < 5.5V$		0.05	0.15	%/V
Transconductance	g_m	$\Delta I=5\mu A$	70	105	240	$\mu A / V$
Voltage Gain	A_v			1,500		V / V
Fault Detect Trigger Voltage	V_{FI}		1.07	1.10	1.14	V

**Electrical Characteristics, $V_{DD}= 3.3V$, $V_{DDH}= 10V$** **Oscillator**

PARAMETER	SYMBOL	TEST CONDITION	MIN	TYP	MAX	UNIT
Oscillation Frequency	f_{OSC}		1,100	1,320	1,600	kHz
Maximum Duty Cycle	D_{MAX}		79	85	92	%

N-Channel Switch

PARAMETER	SYMBOL	TEST CONDITION	MIN	TYP	MAX	UNIT
Current Limit	I_{LIM}		1.1	1.6	2.1	A
On-Resistance	R_{ON}	$I_{SW}=1.2A$		0.28	0.50	Ω
Leakage Current	I_{SWOFF}	$V_{SW}=12V$		0.01	20.00	μA

Control Inputs Characteristics

PARAMETER	SYMBOL	TEST CONDITION	MIN	TYP	MAX	UNIT
Input Low Voltage	V_{IL}				0.3 V_{DD}	V
Input High Voltage	V_{IH}		0.7 V_{DD}			V
Hysteresis	V_{HYS}			0.1 V_{DD}		V
SHDN Pull Up Current	I_{PH}			0.001	1.000	μA

Electrical Characteristics, $V_{DD}= 3.3V$, $V_{DDH}= 10V$

Soft Start & Fault Detect Time

PARAMETER	SYMBOL	TEST CONDITION	MIN	TYP	MAX	UNIT
Channel 1 Soft Start Time	t_{SS1}			14		ms
Channel 2 Soft Start Time	t_{SS2}			3.5		ms
Channel 3 Soft Start Time	t_{SS3}			3.5		ms
Channel 1 to Channel 2 Delay	t_{D12}	AAT1118A		7		ms
Channel 2 to Channel 3 Delay	t_{D23}	AAT1118B		10.5		ms
During Fault Protect Trigger Time	t_{FP}			83		ms
IN1 Fault Protection Voltage	V_{F1}		1.05	1.10	1.15	V
IN2 Fault Protection Voltage	V_{F2}		0.08	0.13	0.18	V
IN3 Fault Protection Voltage	V_{F3}		1.05	1.10	1.15	V



Electrical Characteristics, $V_{DD}= 3.3V$, $V_{DDH}= 10V$

Charge Pump Regulator Characteristics

PARAMETER	SYMBOL	TEST CONDITION	MIN	TYP	MAX	UNIT
V_{DD1} Input Supply Range	V_{DD1}		6		15	V
V_{DD2} Input Supply Range	V_{DD2}		6		15	V
IN2 Threshold Voltage	IN2		-50	0	50	mV
IN3 Threshold Voltage	IN3		1.20	1.25	1.30	V
IN2 Input Bias Current	I_{B2}	$V_{IN2} = -0.05V$	-50		50	nA
IN3 Input Bias Current	I_{B3}	$V_{IN3} = -1.5V$	-50		50	nA
Charge Pump Frequency	f_{OSCP}		540	640	740	kHz
OUT2 Switch R-on	R_{ONP2}			3	20	Ω
	R_{ONN2}			3	20	Ω
OUT3 Switch R-on	R_{ONP3}			3	20	Ω
	R_{ONN3}			3	20	Ω
Continuous Output Current	I_{OUT}				30	mA



BLOCK DIAGRAM
AAT1118/A

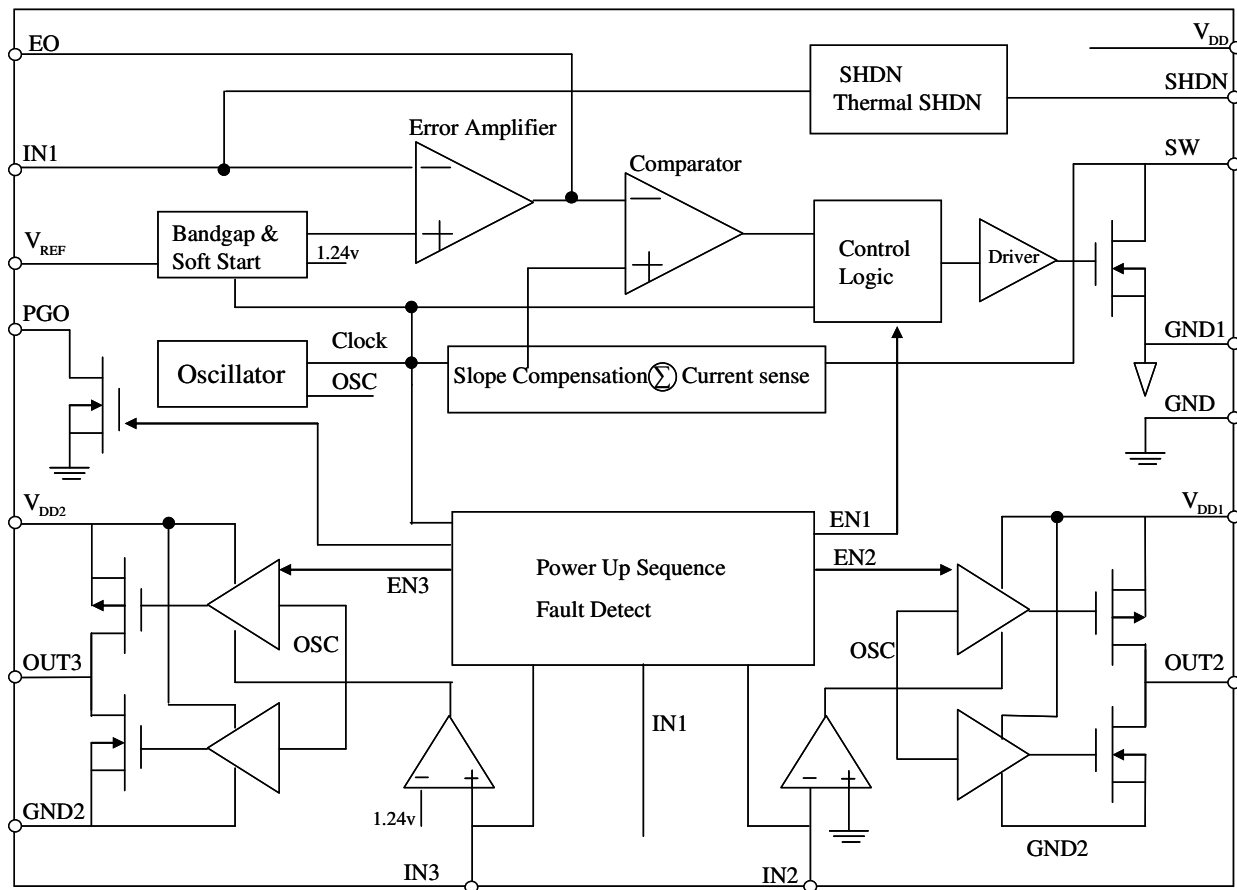



BLOCK DIAGRAM
AAT1118B

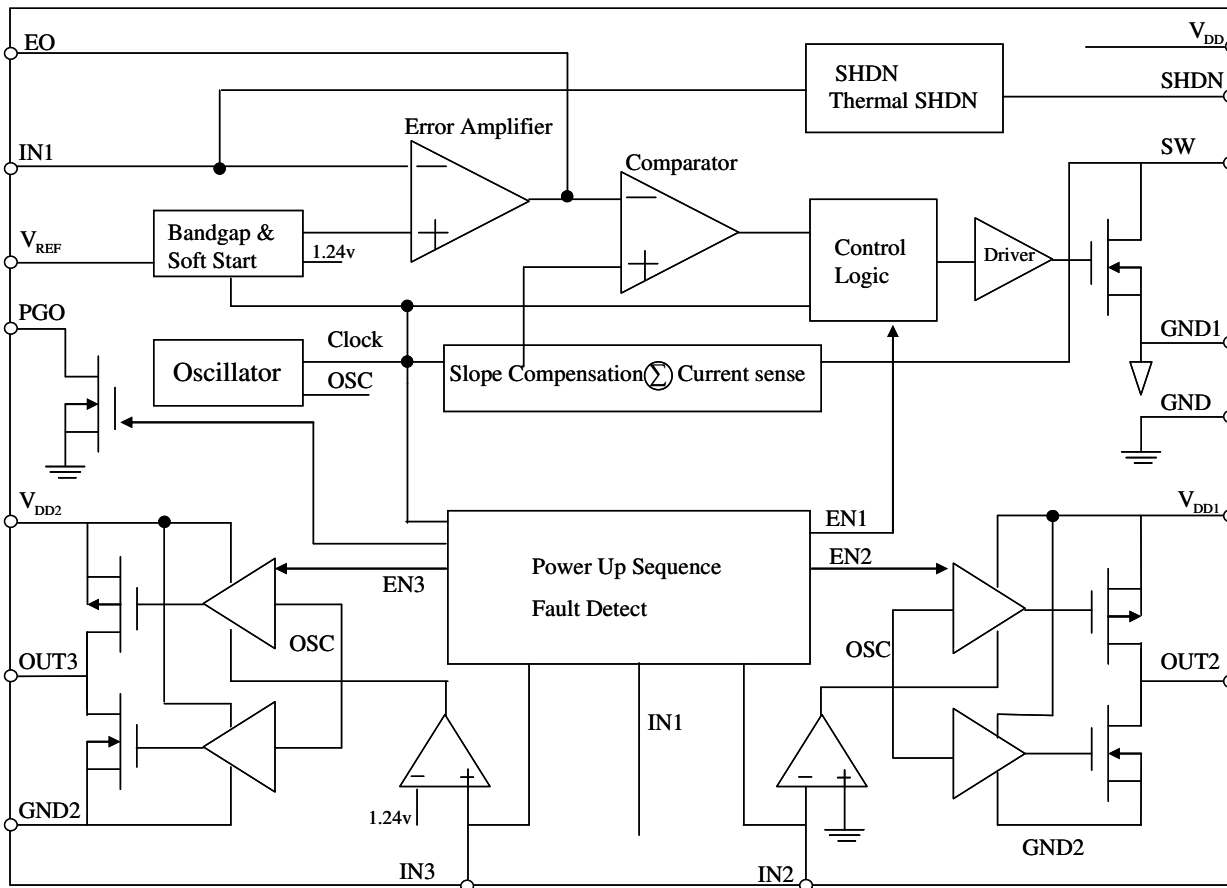



Typical Operating Characteristics

(VIN = 3.3V, T_C = +25°C, unless otherwise noted.)

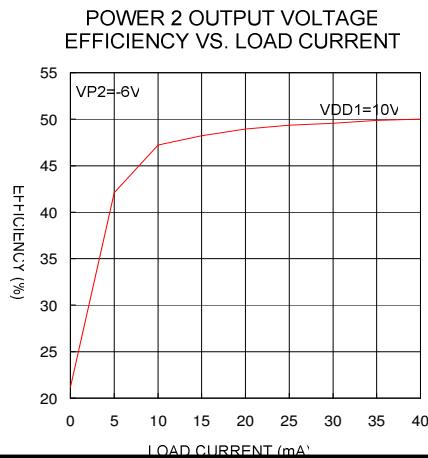
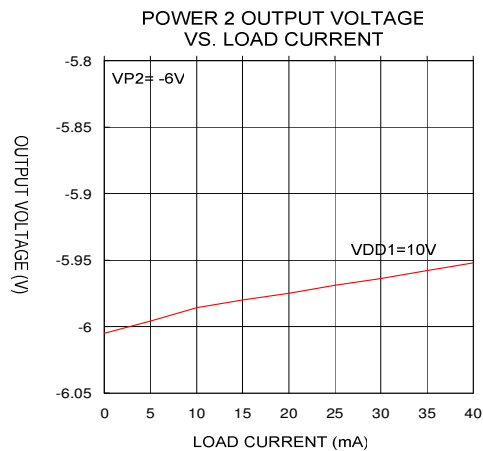
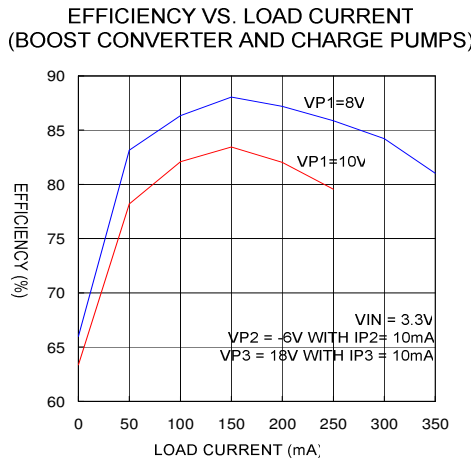
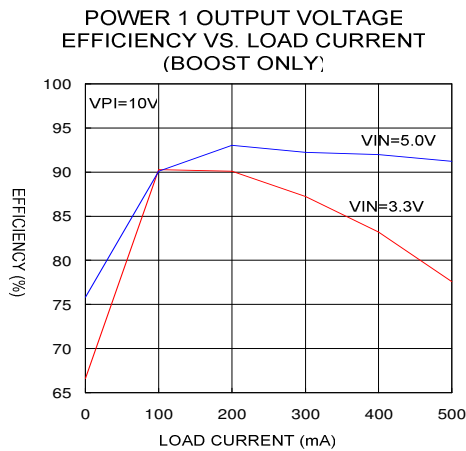
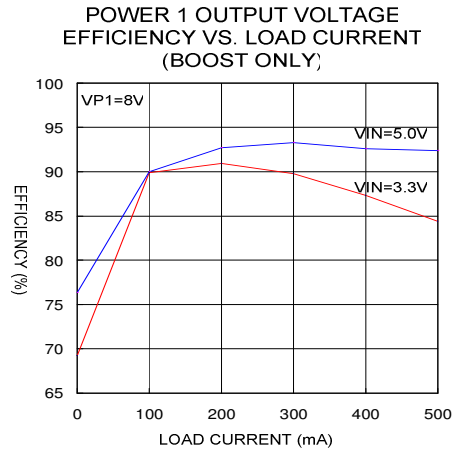
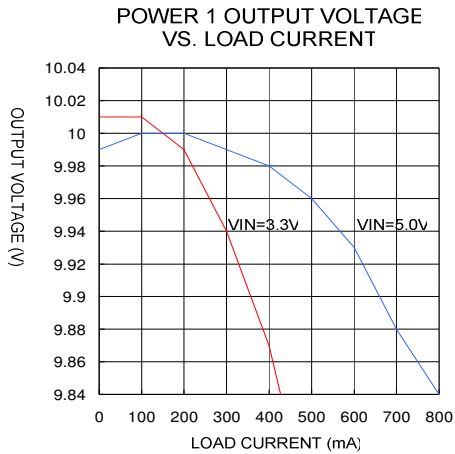



Typical Operating Characteristics (Continued)
(VIN = 3.3V, T_C = +25°C, unless otherwise noted.)

POWER 3 OUTPUT VOLTAGE
VS. LOAD CURRENT

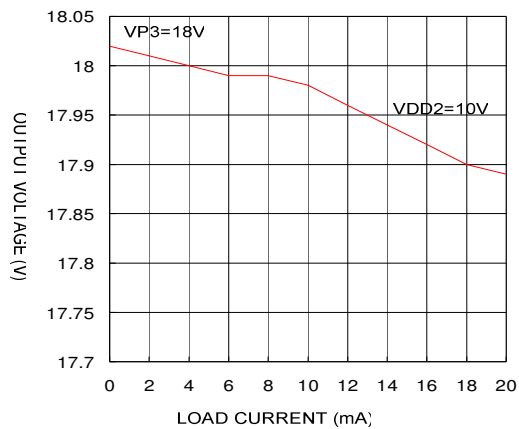

POWER 3 OUTPUT VOLTAGE
EFFICIENCY VS. LOAD CURRENT

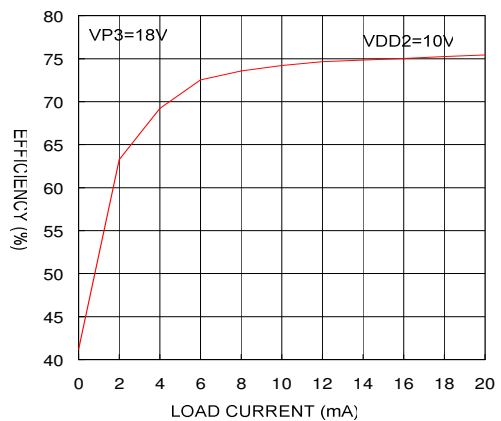

SWITCHING FREQUENCY
VS. INPUT VOLTAGE

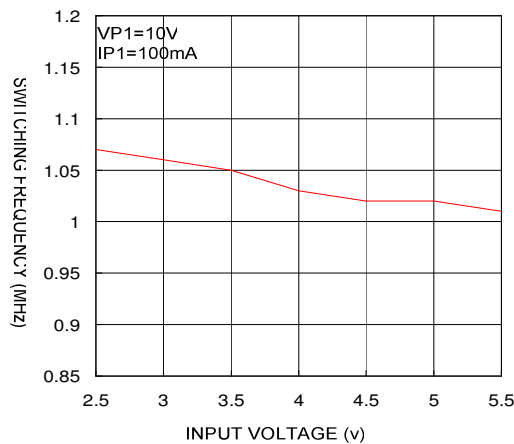

POWER 1 OUTPUT VOLTAGE
START UP WAVEFORM

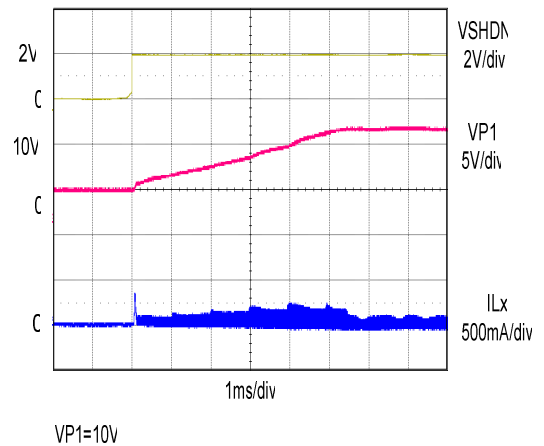



Typical Operating Characteristics (Continued)
(VIN = 3.3V, Tc = +25°C, unless otherwise noted.)

POWER 1 OUTPUT VOLTAGE
WAVEFORM WITH LOAD

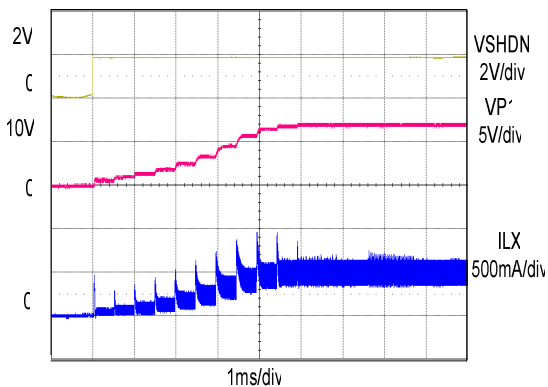

VP1=10V, IP1=200mA

POWER ON SEQUENCING
AAT1118

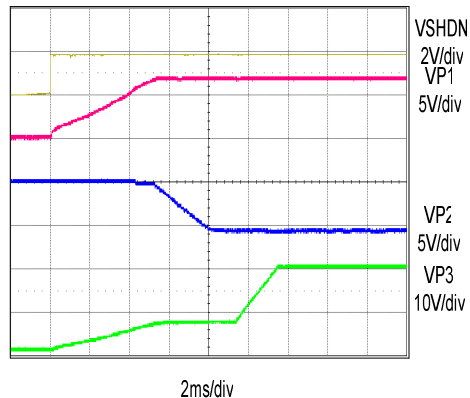

VP1=10V, VP2=-6V, VP3=18V

OUTPUT RIPPLE WAVEFORM

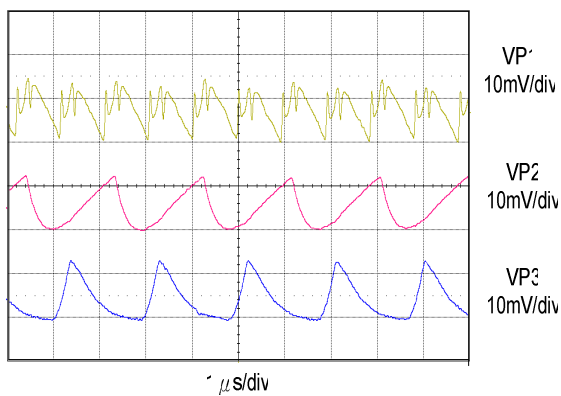

VP1=10V, IP1=200mA
VP2=-6V, IP2=10mA
VP3=18V, IP3=10mA

LOAD TRANSIENT RESPONSE

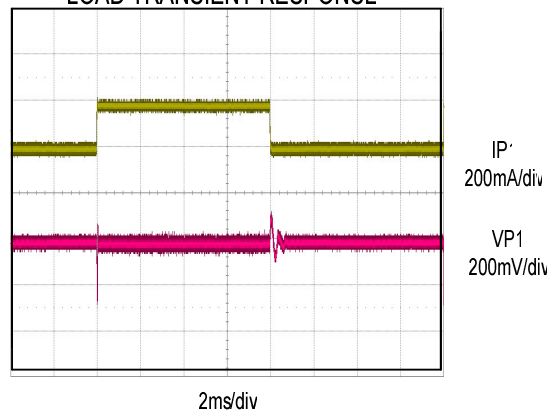

VIN=3.3V, VP1=10V
IP1 (20mA TO 200mA)



Application Circuit
AAT1118/A

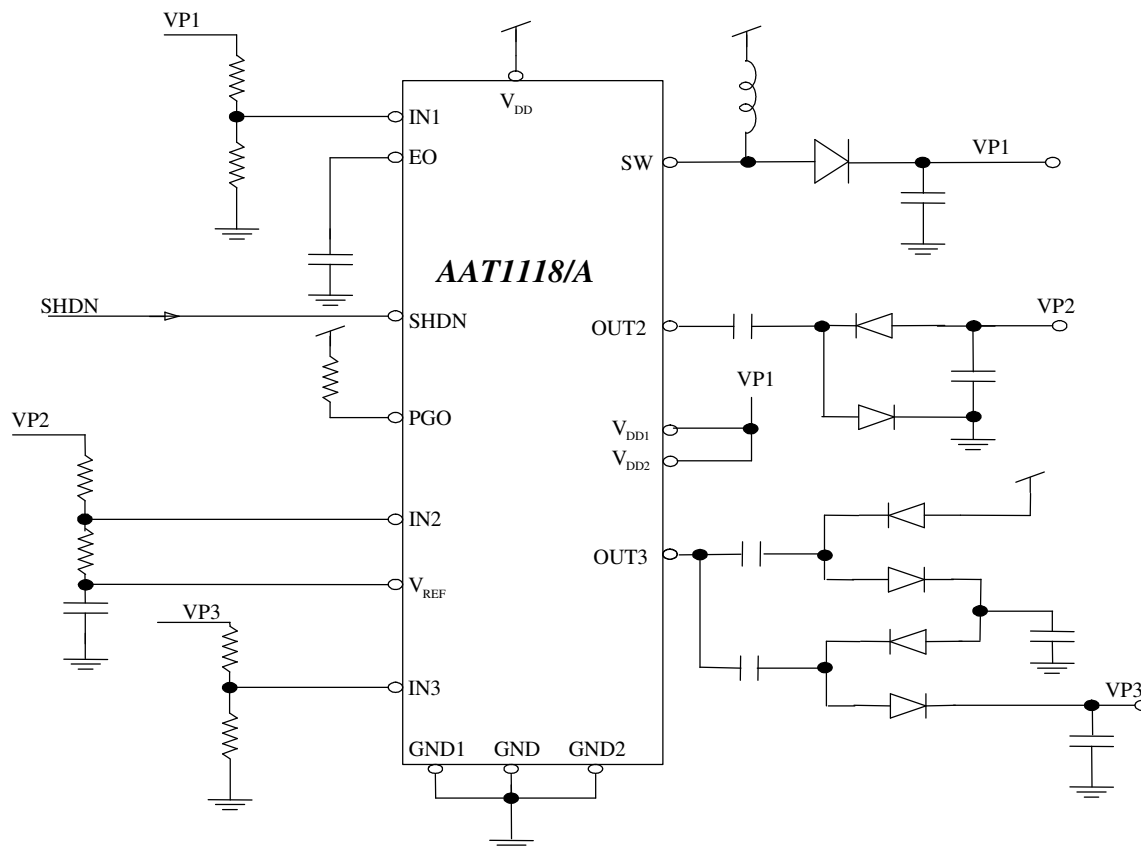



Application Circuit
AAT1118B

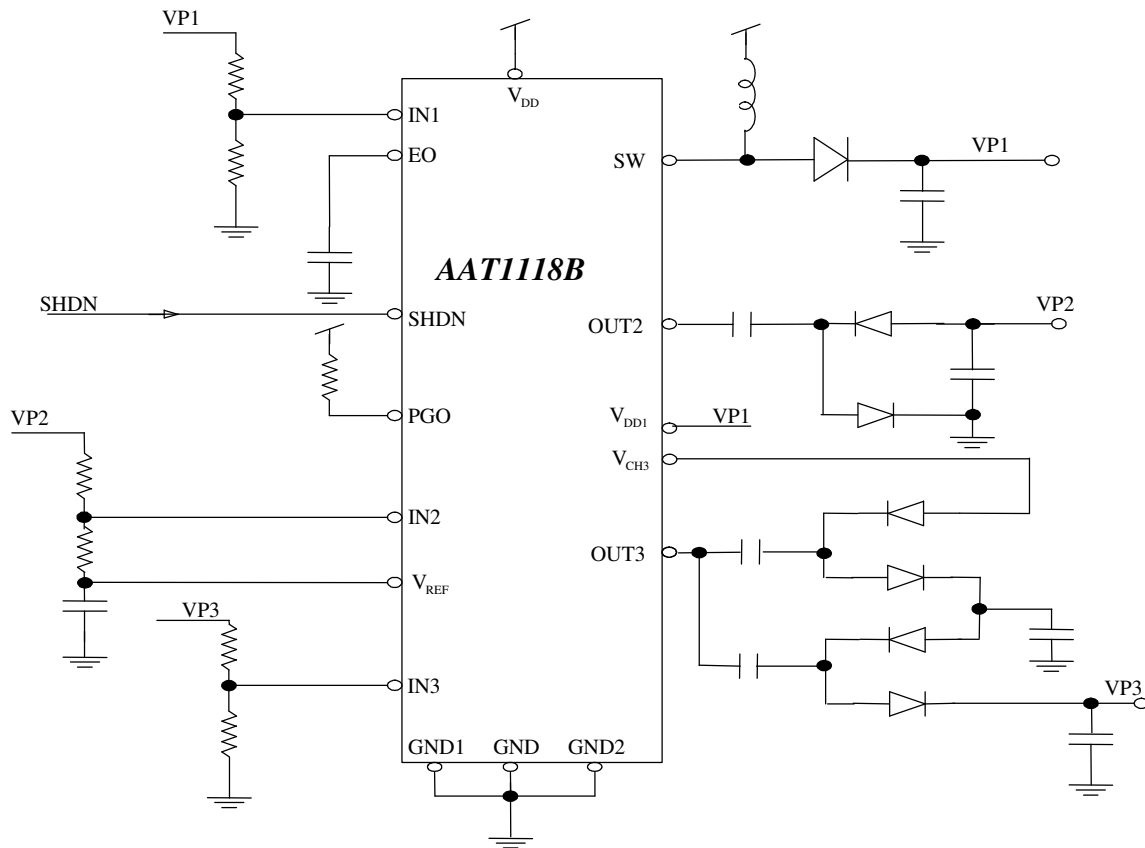



Timing Chart
AAT1118

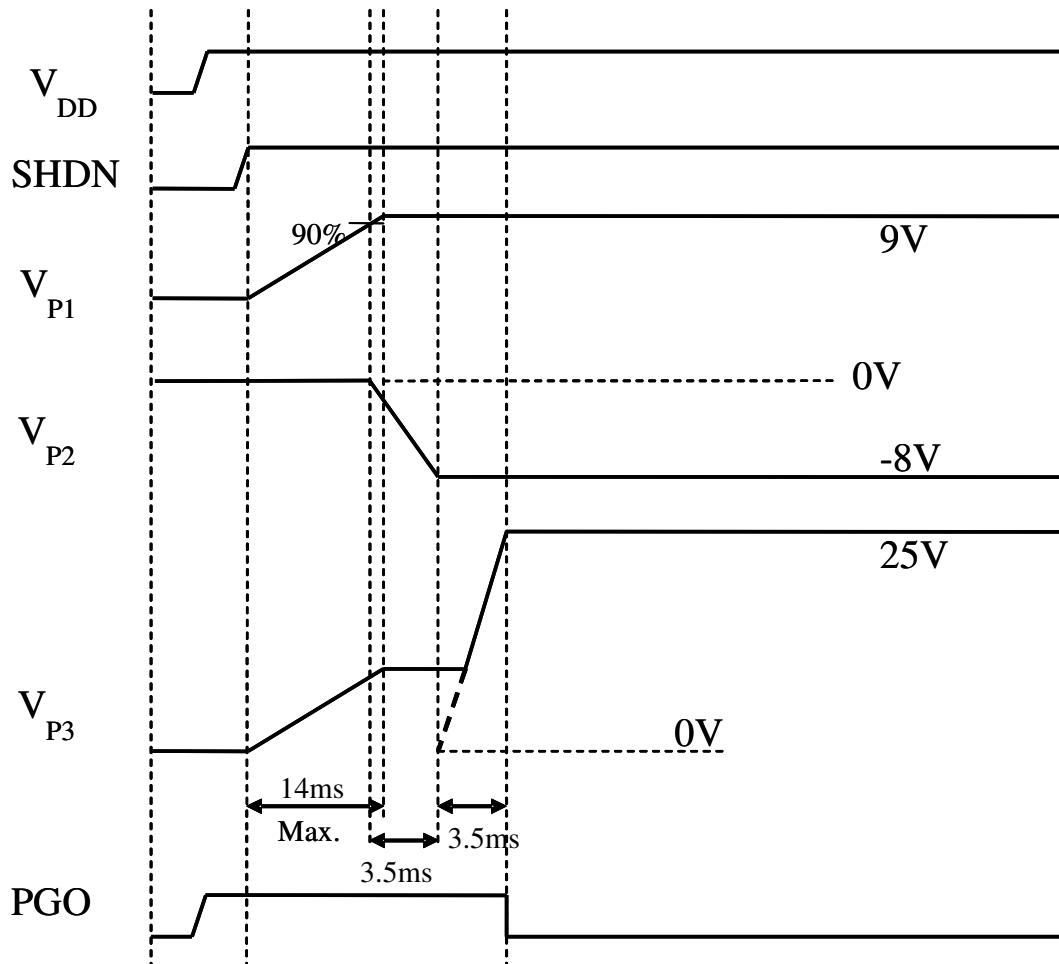



Timing Chart
AAT1118A

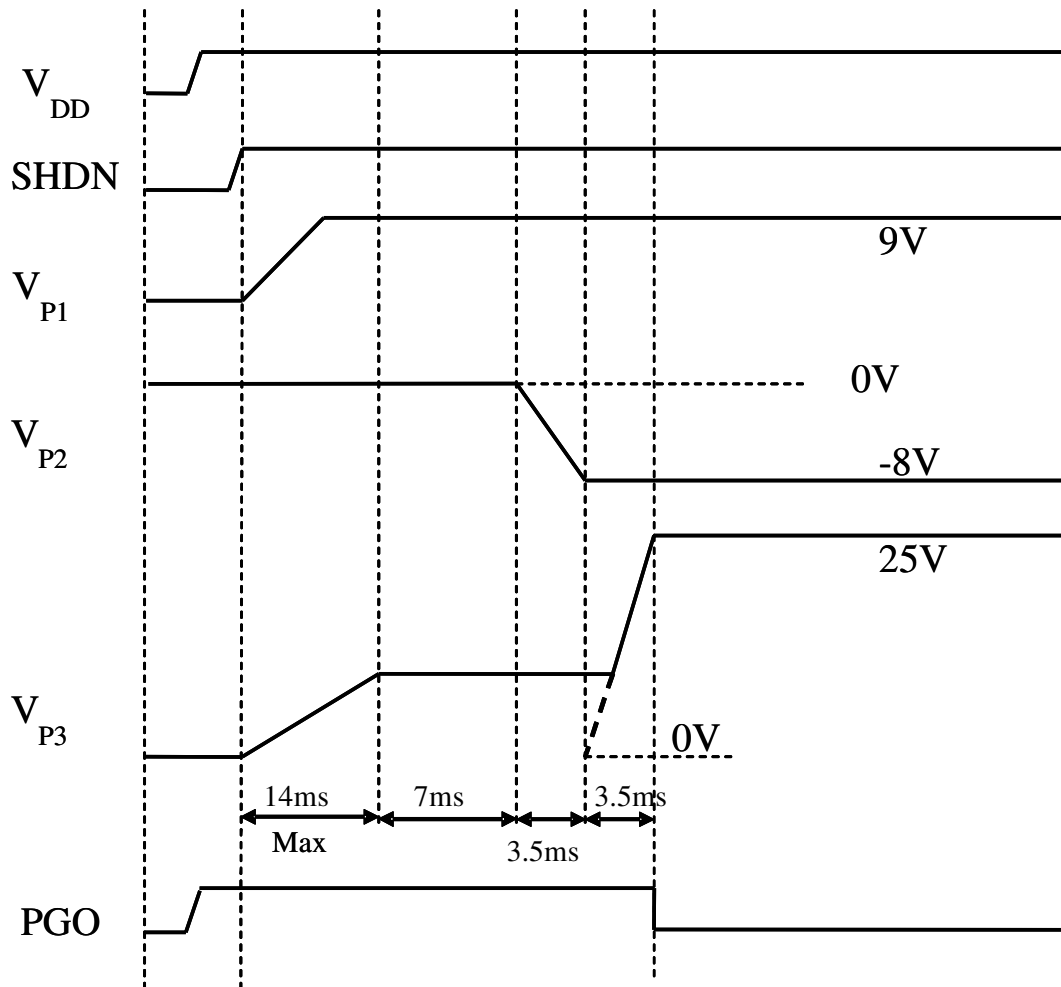



Timing Chart
AAT1118B

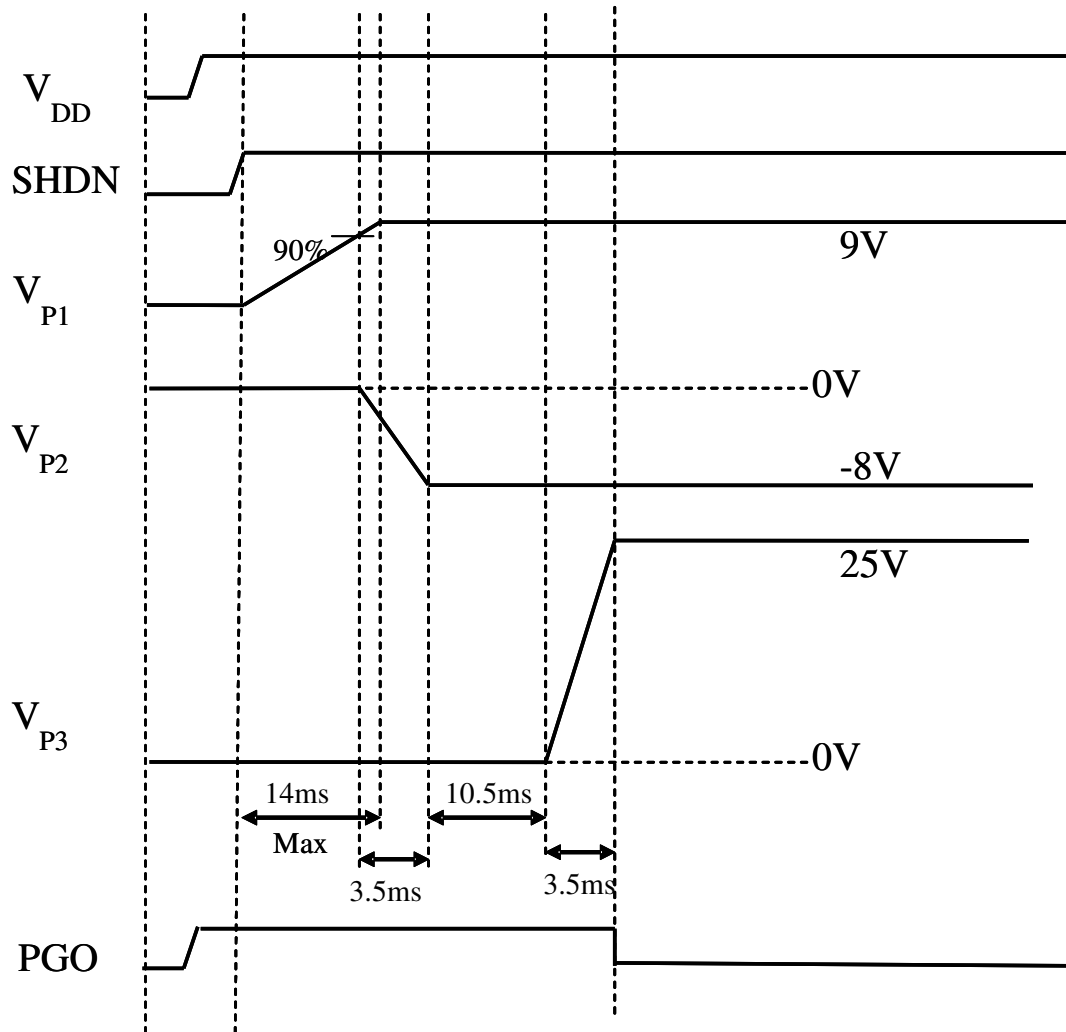



Package Dimension

16-Pin TSSOP

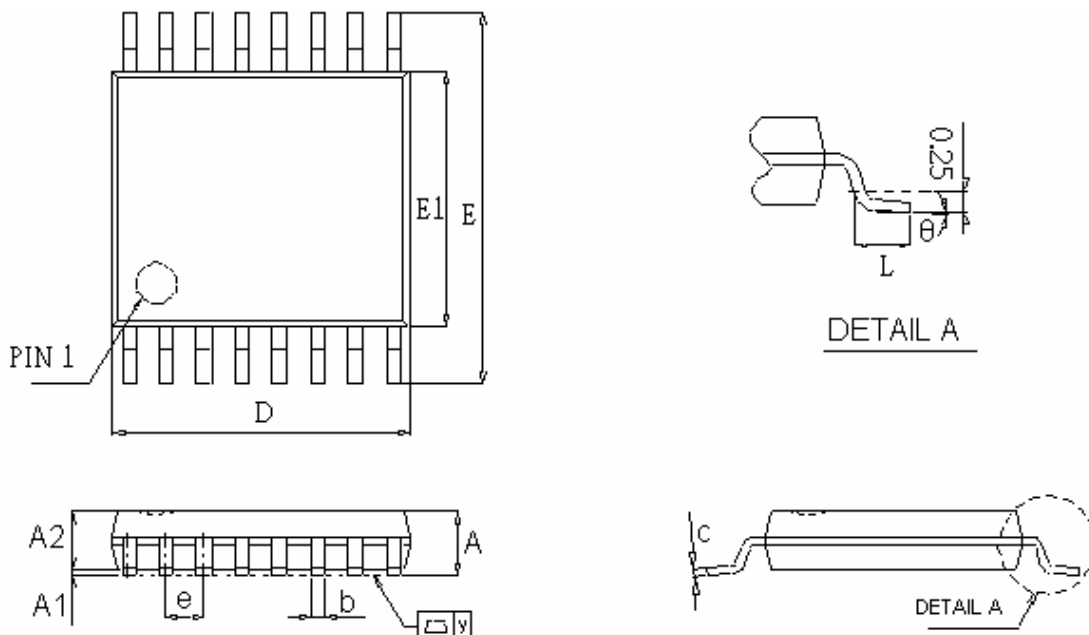

Symbol	Dimensions In Millimeters			Dimensions In Inches		
	Min	TYP	Max	Min	TYP	Max
A	1.05	1.10	1.20	0.041	0.043	0.047
A1	0.05	0.10	0.15	0.002	0.004	0.006
A2	-----	1.00	1.05	-----	0.039	0.041
b	0.20	0.25	0.28	0.008	0.010	0.011
C	-----	0.127	-----	-----	0.005	-----
D	4.900	5.075	5.100	0.1930	0.1998	0.2000
E	6.2	6.4	6.6	0.244	0.252	0.260
E1	4.3	4.4	4.5	0.170	0.173	0.177
e	-----	0.65	-----	-----	0.026	-----
L	0.5	0.6	0.7	0.020	0.024	0.028
y	-----	-----	0.076	-----	-----	0.003
θ	0°	4°	8°	0°	4°	8°