

## 10 Gigabit/s Transceiver with XAUI Interface

The TenGiPHY™-L is a single chip transceiver IC for 10 Gbit/s Ethernet and Fibre Channel connectivity. It offers a serial, full duplex 10 Gbit/s, XFI compliant interface to optical components or to a serial fiber-optic module (XFP). The integrated CDR and CMU operate at a data rate of 10.3125 or 10.51875 Gbit/s. The TenGiPHY-L provides the XGXS, PCS and PMA sublayers of the 10 Gbit/s Ethernet and Fibre Channel standards.

At the system side, a quad serial XAUI interface connects the TenGiPHY-L to the upper layers.

The networking system can control the chip via a narrow-width MDIO interface by writing and reading its control and status registers.



### Applications

- Fiber optic modules according to the XENPAK multi-source agreement
- 10 Gbit/s Ethernet line cards
- 10 Gbit/s Fibre Channel line and NIC cards
- Terabit Routers

### Features

- Complete 10 Gbit/s Ethernet and Fibre Channel PHY device supporting LAN applications
- Complies with IEEE 802.3ae
- Complies with ANSI 1413-D
- Compliant to XENPAK multi-source agreement
- Embedded  $\mu$ Controller allows for control and tuning of the PMDs via analog interfaces

- Clock & data recovery and clock multiplying unit without external loop filter components
- Supports various clocking modes based on external reference clocks, loop- and external timing
- Integrated bit error rate tester (BERT) usable for multiple at-speed diagnostic scenarios
- Includes the XGXS, PCS, and PMA sublayers of the OSI protocol stack
- Synchronization and de-skewing of XAUI lanes
- Performs 8B/10B (de-)coding required for the XGXS sublayer
- Various loop back modes for system debugging
- Provides access to E<sup>2</sup>PROM via I<sup>2</sup>C interface according to XENPAK requirements; automatic E<sup>2</sup>PROM download on power-up
- Power-efficient design: <1.3W @ 1.3V

### Interfaces

- Full duplex, XFI compliant serial CML line interface for data rates between 10.3 and 10.5 Gbit/s
- Quad serial Gbit/s XAUI interface with data rates between 3.1 and 3.2 Gbit/s
- MDIO interface
- I<sup>2</sup>C interface
- XENPAK diagnostic interface providing eight 12-bit ADCs and four 10-bit DACs
- IEEE 1149.1 JTAG boundary scan interface

# UPF 01012

## TenGiPHY™-L



Never stop thinking.

## Block Diagram

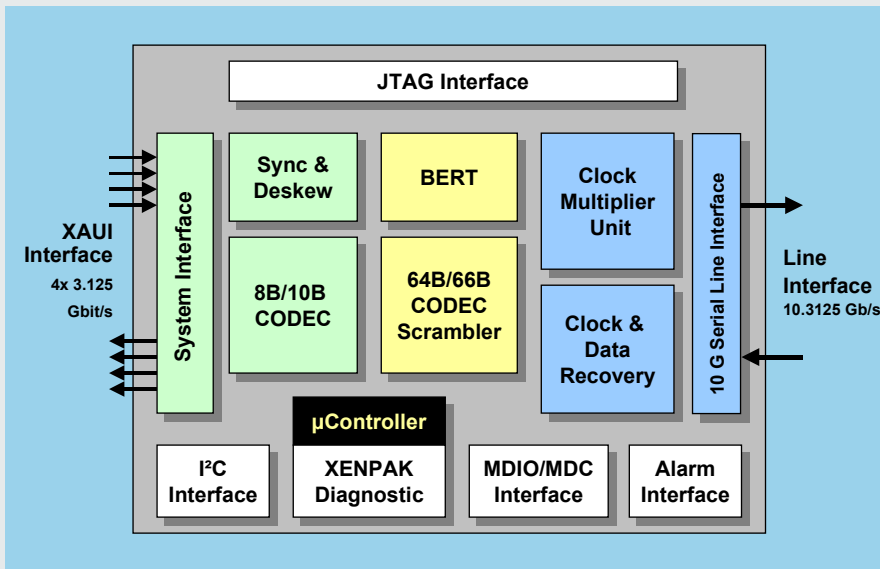

### Documentation and Support Package

- Data Sheet
- **Hardware Evaluation System** includes mother- and transponder board
- **WINEASY** Software for MS Windows with graphical user interface
- **Application Assistant:** Configuration Software for MS Windows for device initialization

Type	Sales Code	Package
TenGiPHY-L	UPF 01012	P-FCHBGA-177-1

## Application Example

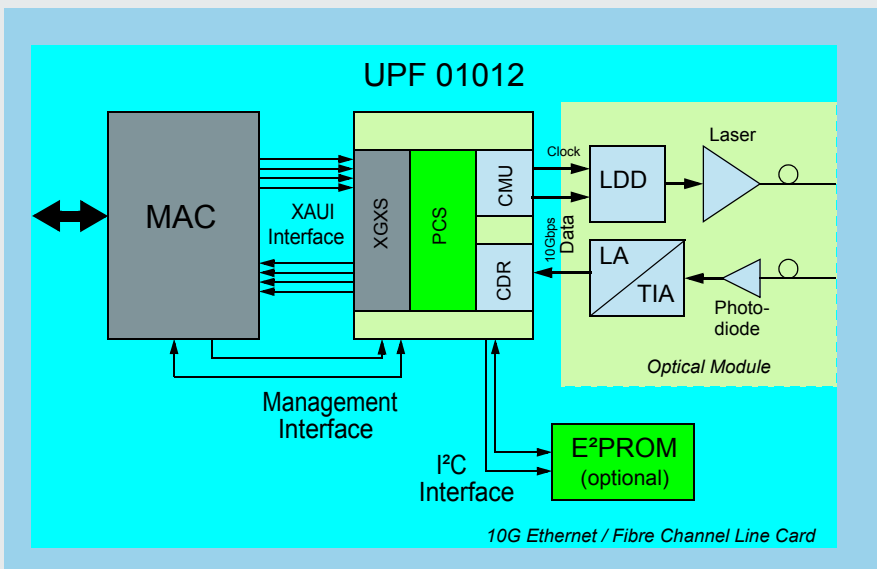

How to reach us:

<http://www.infineon.com>

Published by  
Infineon Technologies AG,  
Bereich Kommunikation,  
St.-Martin-Strasse 53,  
D-81541 München

© Infineon Technologies AG 2002. All Rights Reserved.

### Attention please!

The information herein is given to describe certain components and shall not be considered as warranted characteristics.

Terms of delivery and rights to technical change reserved.

We hereby disclaim any and all warranties, including but not limited to warranties of non-infringement, regarding circuits, descriptions and charts stated herein.

Infineon Technologies is an approved CECC manufacturer.

### Information

For further information on technology, delivery terms and conditions and prices please contact your nearest Infineon Technologies Office in Germany or our Infineon Technologies Representatives worldwide.

### Warnings

Due to technical requirements components may contain dangerous substances. For information on the types in question please contact your nearest Infineon Technologies Office.

Infineon Technologies Components may only be used in life-support devices or systems with the express written approval of Infineon Technologies, if a failure of such components can reasonably be expected to cause the failure of that life-support device or system, or to affect the safety or effectiveness of that device or system. Life support devices or systems are intended to be implanted in the human body, or to support and/or maintain and sustain and/or protect human life. If they fail, it is reasonable to assume that the health of the user or other persons may be endangered.