



# STW81100

## MULTI-BAND RF FREQUENCY SYNTHESIZER WITH INTEGRATED VCOs

DATASHEET

### 1 Features

- Integer-N Frequency Synthesizer
- Dual differential integrated VCOs with automatic center frequency calibration:
  - Direct Output:
    - 3280 – 3900 MHz
    - 3800 – 4400 MHz
  - Internal divider by 2:
    - 1640 – 1950 MHz
    - 1900 – 2200 MHz
  - Internal divider by 4:
    - 820 – 975 MHz
    - 950 – 1100 MHz
- Fast lock time: 150µs
- Dual modulus prescaler (64/65) and 2 programmable counters to achieve a feedback division ratio from 4096 to 32767.
- Programmable reference frequency divider (9 bits)
- Phase frequency comparator and charge pump
- Programmable charge pump current
- Digital Lock Detector
- I<sup>2</sup>C bus interface with 3 bit programmable address (1100A<sub>2</sub>A<sub>1</sub>A<sub>0</sub>)
- 3.3V Power Supply
- Power down mode
- Small size exposed pad VFQFPN28 package 5x5x1.0mm
- Process: BICMOS 0.35µm SiGe

### 2 Description

The STMicroelectronics STW81100 is an integrated RF synthesizer and voltage controlled oscillators (VCOs).

Figure 1. Package

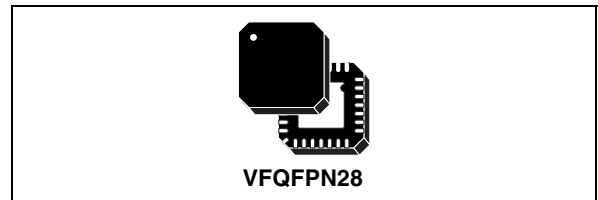

Table 1. Order Codes

Part Number	Package
STW81100AT	VFQFPN28
STW81100ATR	VFQFPN28 in Tape & Reel

tors (VCOs).

Showing high performance, high integration, low power, and multi-band performances, STW81100 is a low cost one chip alternative to discrete PLL and VCOs solutions.

STW81100 includes an Integer-N frequency synthesizer and two fully integrated VCOs featuring low phase noise performance and a noise floor of -153dBc/Hz. The combination of wide frequency range VCOs (thanks to center-frequency calibration over 32 sub-bands) and multiple output options (direct output, divided by 2 or divided by 4) allows to cover the 820MHz-1100MHz, the 1640MHz-2200MHz and the 3280MHz-4400MHz bands.

The STW81100 is designed with STMicroelectronics advanced 0.35µm SiGe process.

### 3 Applications

- Cellular 3G Infrastructure Equipment
- Other Wireless Communication Systems

Figure 2. Block Diagram

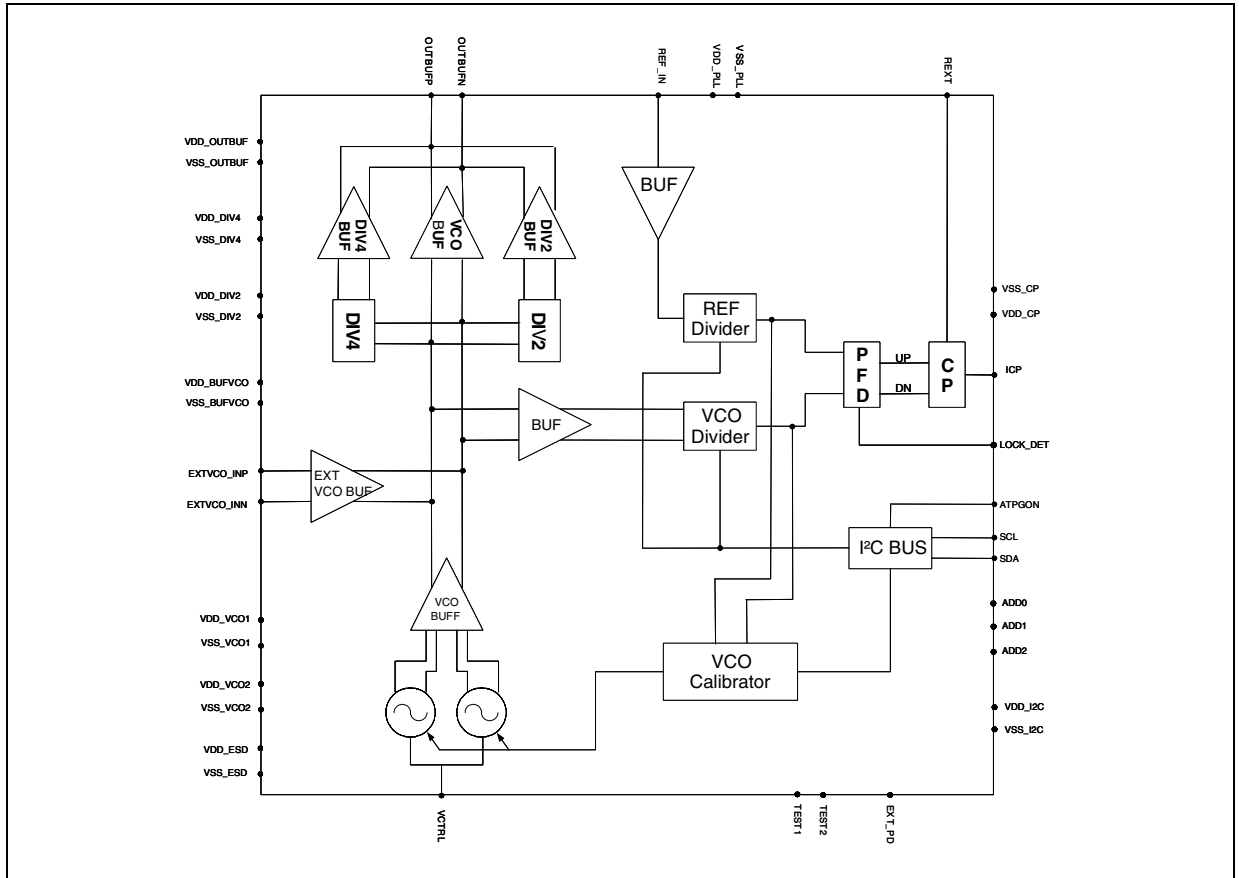

Figure 3. Pin Connections

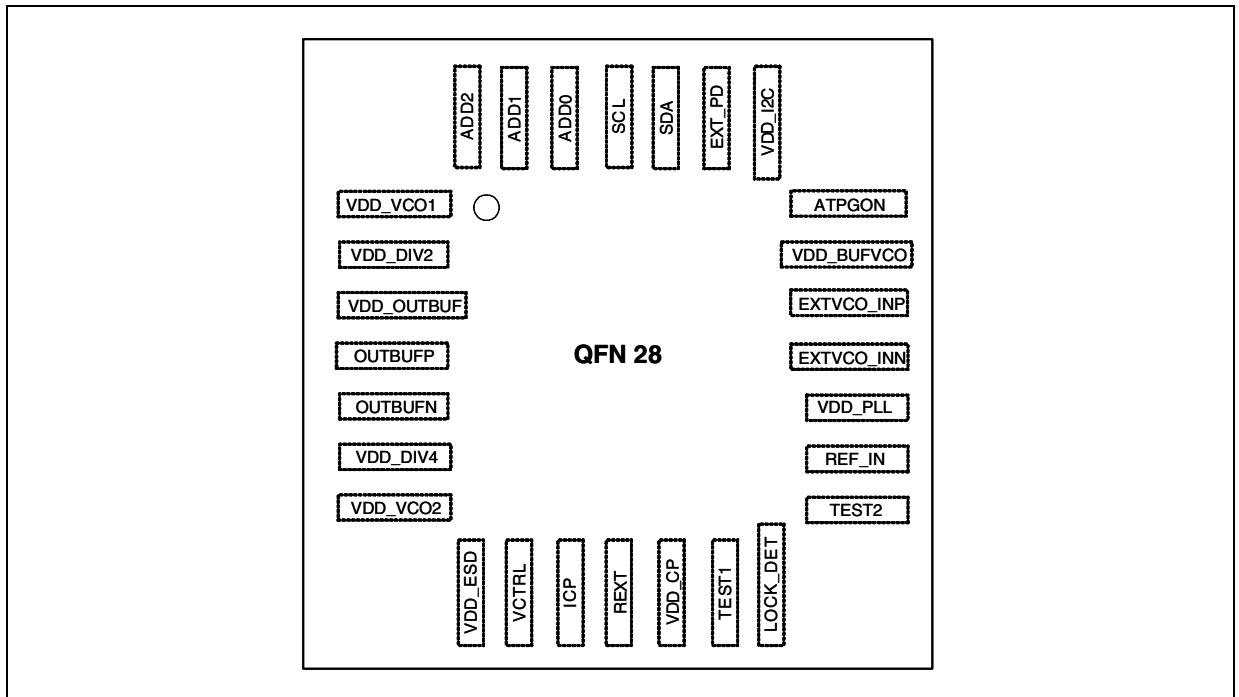

Table 2. Pin Description

Pin No	Name	Description	Observations
1	VDD_VCO1	VCO power supply	
2	VDD_DIV2	Divider by 2 power supply	
3	VDD_OUTBUF	Output buffer power supply	
4	OUTBUFP	LO buffer positive output	Open collector
5	OUTBUFN	LO buffer negative output	Open collector
6	VDD_DIV4	Divider by 4 power supply	
7	VDD_VCO2	VCO power supply	
8	VDD_ESD	ESD positive rail power supply	
9	VCTRL	VCO control voltage	
10	ICP	PLL charge pump output	
11	REXT	External resistance connection for PLL charge pump	
12	VDD_CP	Power supply for charge pump	
13	TEST1	Test input 1	Used only for testing purpose
14	LOCK_DET	Lock detector	CMOS Output
15	TEST2	Test input 2	Used only for testing purpose
16	REF_IN	Reference frequency input	
17	VDD_PLL	PLL digital power supply	
18	EXTVCO_INN	External VCO negative input	
19	EXTVCO_INP	External VCO positive input	
20	VDD_BUFVCO	VCO buffer power supply	
21	ATPGON	SCAN mode activated	
22	VDD_I <sup>2</sup> C	I <sup>2</sup> C bus power supply	
23	EXT_PD	Power down hardware	CMOS Input
24	SDA	I <sup>2</sup> CBUS data line	CMOS Bidir Schmitt triggered
25	SCL	I <sup>2</sup> CBUS clock line	CMOS Input
26	ADD0	I <sup>2</sup> CBUS address select pin	CMOS Input
27	ADD1	I <sup>2</sup> CBUS address select pin	CMOS Input
28	ADD2	I <sup>2</sup> CBUS address select pin	CMOS Input

**Table 3. Absolute Maximum Ratings**

Symbol	Parameter	Values	Unit
$V_{CC}$	Analog Supply voltage	0 to 4.6	V
$DV_{CC}$	Digital Supply voltage	0 to 4.6	V
$T_{stg}$	Storage temperature	+150	°C
ESD	Electrical Static Discharge - HBM - CDM-JEDEC Standard	2 0.5	KV

**Table 4. Operating Conditions**

Symbol	Parameter	Test conditions	Min	Typ	Max	Unit
$V_{CC}$	Analog Supply voltage		3.0	3.3	3.6	V
$DV_{CC}$	Digital Supply voltage		3.0	3.3	3.6	V
$I_{CC}$	Current Consumption				100	mA
$T_{amb}$	Operating ambient temperature		-40		85	°C
$T_j$	Maximum junction temperature				125	°C
$R_{th\ j-a}$	Junction to ambient package thermal resistance	Multilayer JEDEC board		35		°C/W

**Table 5. Digital Logic Level**

Symbol	Parameter	Test conditions	Min	Typ	Max	Unit
$V_{il}$	Low level input voltage				$0.2 \cdot V_{DD}$	V
$V_{ih}$	High level input voltage		$0.8 \cdot V_{DD}$			V
$V_{hyst}$	Schmitt trigger hysteresis		0.8			V
$V_{ol}$	Low level output voltage				0.4	V
$V_{oh}$	High level output voltage		$0.85 \cdot V_{DD}$			V

## 4 Electrical Characteristics

All Electrical Specifications are intended at 3.3V supply voltage.

**Table 6. Electrical Characteristics**

Symbol	Parameter	Test Condition	Min	Typ	Max	Units
<b>REFERENCE</b>						
$f_{ref}$	Reference input frequency		10	19.2	100	MHz
	Reference input sensitivity		0.35	1	1.5	V <sub>peak</sub>
$f_{comp}$	Comparison frequency		200	400	10000	KHz
$f_{step}$	Frequency step	LO direct output	200	400	10000	KHz
		LO with Divider by 2	100	200	5000	KHz
		LO with Divider by 4	50	100	2500	KHz

Table 6. Electrical Characteristics (continued)

CHARGE PUMP						
Symbol	Parameter	Test Condition	Min	Typ	Max	Units
I <sub>CP</sub>	ICP sink/source <sup>1</sup>	3bit programmable			4	mA
V <sub>OCP</sub>	Output voltage compliance range		0.4		V <sub>dd</sub> -0.3	V
	Spurious <sup>2,3</sup>	Direct Output		-65	-54	dBc
		Divider by 2		-70	-60	dBc
		Divider by 4		-70	-66	dBc
VCOs						
K <sub>VCOA</sub>	VCOA sensitivity <sup>3</sup>	Sub-Band 00000	85	105	135	MHz/V
		Sub-Band 01111	55	70	95	MHz/V
		Sub-Band 11111	35	50	65	MHz/V
K <sub>VCOB</sub>	VCOB sensitivity <sup>3</sup>	Sub-Band 00000	60	75	100	MHz/V
		Sub-Band 01111	35	45	60	MHz/V
		Sub-Band 11111	20	25	35	MHz/V
	VCO <sub>A</sub> Pushing <sup>3</sup>			7	10	MHz/V
	VCO <sub>B</sub> Pushing <sup>3</sup>			9	14	MHz/V
	VCO control voltage		0.4		3	V
	LO Harmonic Spurious				-20	dBc
	VCO current consumption			25		mA
	VCO buffer consumption			15		mA
I <sub>DIV2</sub>	DIVIDER by 2 consumption			18		mA
I <sub>DIV4</sub>	DIVIDER by 4 consumption			14		mA
LO OUTPUT BUFFER						
P <sub>OUT</sub>	Output level			0		dBm
RL	Return Loss	Matched to 50ohm		15		dB
I <sub>LOBUF</sub>	Current Consumption	DIV4 Buff		26		mA
		DIV2 Buff		23		mA
		Direct Output		37		mA
EXTERNAL VCO (Test purpose only)						
f <sub>INVCO</sub>	Frequency range		3.28		4.4	GHz
P <sub>IN</sub>	Input level		0		+6	dBm
V <sub>INDC</sub>	DC Input level			2		V
I <sub>EXTBUF</sub>	Current Consumption	VCO Internal Buffer		15		mA

Table 6. Electrical Characteristics (continued)

PLL MISCELLANEOUS						
$I_{PLL}$	Current Consumption	Input Buffer, Prescaler, Digital Dividers, misc		10		mA
$t_{LOCK}$	Lock up time	40 KHz PLL bandwidth; within 1 ppm of frequency error		150		$\mu$ s

Notes: 1. : see relationship between ICP and REXT in the Circuit Description section (Charge Pump)

2. : Comparison frequency leakage (400KHz) and harmonics

3. : Guaranteed by design and characterization.

Table 7. Phase Noise Performance<sup>1)</sup>

Parameter	Test Condition	Min	Typ	Max	Units
<b>In Band Phase Noise – Closed Loop<sup>2)</sup></b>					
Normalized In Band Phase Noise Floor	ICP=2mA, PLL BW = 50KHz; including reference clock contribution		-212		dBc/Hz
In Band Phase Noise Floor Direct Output			-212+20log(N)+10log(f <sub>comp</sub> )		dBc/Hz
In Band Phase Noise Floor Divider by 2			-218+20log(N)+10log(f <sub>comp</sub> )		dBc/Hz
In Band Phase Noise Floor Divider by 4			-224+20log(N)+10log(f <sub>comp</sub> )		dBc/Hz
<b>PLL Integrated Phase Noise with Divider by 2</b>					
Integrated Phase Noise (single sided) 400Hz to 4MHz	ICP = 4mA, f <sub>comp</sub> = 400KHz (N = 10000), PLL BW = 15KHz		-39	-37	dBc
Integrated Phase Noise (single sided) 100Hz to 25MHz			-38	-36	dBc
<b>VCO A Direct (3280MHz-3900MHz) – Open Loop</b>					
Phase Noise @ 1 KHz			-56	-53	dBc/Hz
Phase Noise @ 10 KHz			-83	-82	dBc/Hz
Phase Noise @ 100 KHz			-105	-102	dBc/Hz
Phase Noise @ 1 MHz			-128	-125	dBc/Hz
Phase Noise @ 10 MHz			-148	-145	dBc/Hz
Phase Noise @ 40 MHz			-156	-153	dBc/Hz
<b>VCO B Direct (3800MHz-4400MHz) – Open Loop</b>					
Phase Noise @ 1 KHz			-55	-52	dBc/Hz
Phase Noise @ 10 KHz			-82	-79	dBc/Hz
Phase Noise @ 100 KHz			-104	-101	dBc/Hz
Phase Noise @ 1 MHz			-127	-124	dBc/Hz
Phase Noise @ 10MHz			-147	-143	dBc/Hz
Phase Noise @ 40 MHz			-155	-152	dBc/Hz
<b>VCO A with divider by 2 (1640MHz-1950MHz) – Open Loop</b>					
Phase Noise @ 1 KHz			-62	-59	dBc/Hz
Phase Noise @ 10 KHz			-89	-86	dBc/Hz
Phase Noise @ 100 KHz			-111	-108	dBc/Hz
Phase Noise @ 1 MHz			-134	-131	dBc/Hz
Phase Noise @ 10 MHz			-150	-148	dBc/Hz
Phase Noise @ 20 MHz			-152	-150	dBc/Hz
Phase Noise Floor @ 40 MHz			-153	-151	dBc/Hz

Table 7. (continued)

Parameter	Test Condition	Min	Typ	Max	Units
<b>VCO B with divider by 2 (1900MHz-2200MHz) – Open Loop</b>					
Phase Noise @ 1 KHz			-61	-58	dBc/Hz
Phase Noise @ 10 KHz			-88	-85	dBc/Hz
Phase Noise @ 100 KHz			-110	-107	dBc/Hz
Phase Noise @ 1 MHz			-133	-130	dBc/Hz
Phase Noise @ 10MHz			-150	-148	dBc/Hz
Phase Noise @ 20MHz			-152	-150	dBc/Hz
Phase Noise Floor @ 40 MHz			-153	-151	dBc/Hz
<b>VCO A with divider by 4 (820MHz-975MHz) – Open Loop</b>					
Phase Noise @ 1 KHz			-68	-65	dBc/Hz
Phase Noise @ 10 KHz			-95	-92	dBc/Hz
Phase Noise @ 100 KHz			-117	-114	dBc/Hz
Phase Noise @ 1 MHz			-139	-136	dBc/Hz
Phase Noise @ 10MHz			-151	-149	dBc/Hz
Phase Noise Floor @ 40 MHz			-153	-151	dBc/Hz
<b>VCO B with divider by 4 (950MHz-1100MHz) – Open Loop</b>					
Phase Noise @ 1 KHz			-67	-64	dBc/Hz
Phase Noise @ 10 KHz			-94	-91	dBc/Hz
Phase Noise @ 100 KHz			-116	-113	dBc/Hz
Phase Noise @ 1 MHz			-138	-135	dBc/Hz
Phase Noise @ 10MHz			-151	-149	dBc/Hz
Phase Noise Floor @ 40 MHz			-153	-151	dBc/Hz

Note 1): Phase Noise SSB.

VCO amplitude set to maximum value [11].

The phase noise is measured with the Agilent E5052A Signal Source Analyzer.

All the closed-loop performances are specified using a Reference Clock signal at 19.2 MHz with phase noise of -141dBc/Hz @ 1KHz offset and -146dBc/Hz @ 10KHz offset. All figures are guaranteed by design and characterization.

Note 2): Normalized PN = Measured PN - 20log(N) - 10log(fcomp) where N is the VCO divider ratio (N=B\*P+A) and fcomp is the comparison frequency at the PFD input

## 5 Typical Performance Characteristics

The phase noise is measured with the Agilent E5052A Signal Source Analyzer. All the closed-loop measurements are done with  $f_{comp}=800$  KHz and using a Reference Clock signal at 19.2 MHz with phase noise of  $-141\text{dBc/Hz}$  @ 1KHz offset and  $-146\text{dBc/Hz}$  @ 10KHz offset.

**Figure 4. VCO A (Direct output) open loop phase noise**

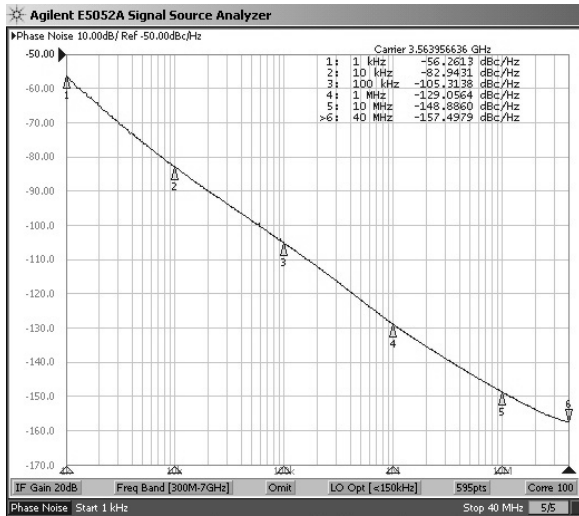

**Figure 6. VCO B (Direct output) open loop phase noise**

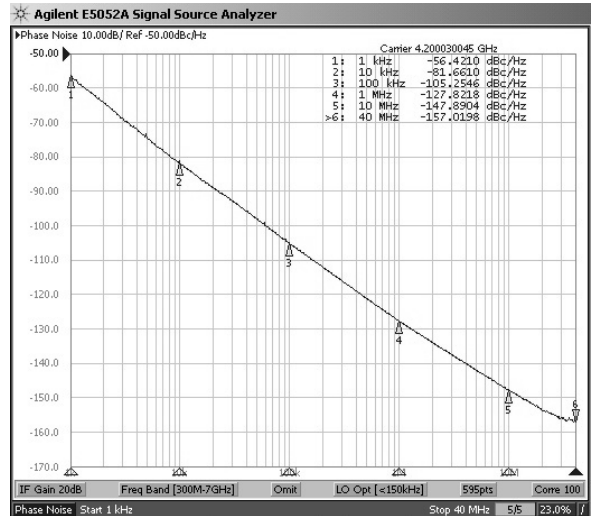

**Figure 5. VCO A (Direct output) closed loop phase noise**

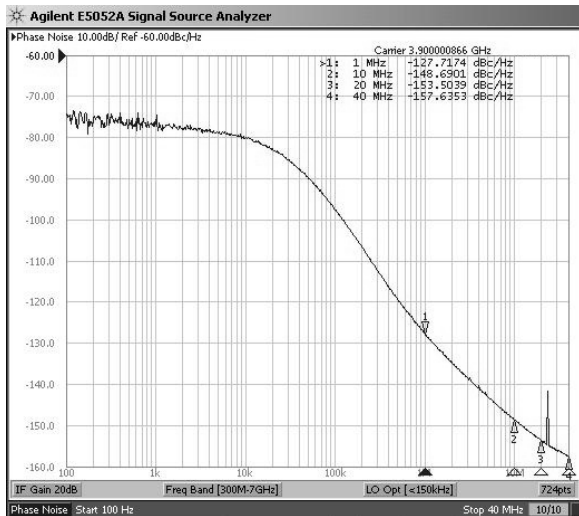

**Figure 7. VCO B (Direct output) closed loop phase noise**

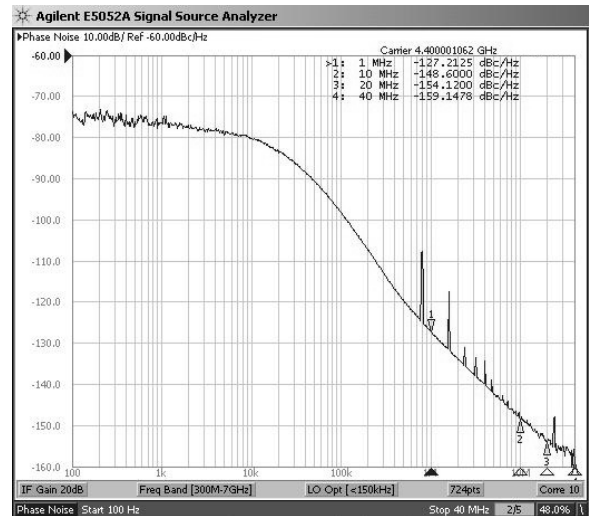



Figure 8. VCO A (Divider by 2 output) closed loop phase noise

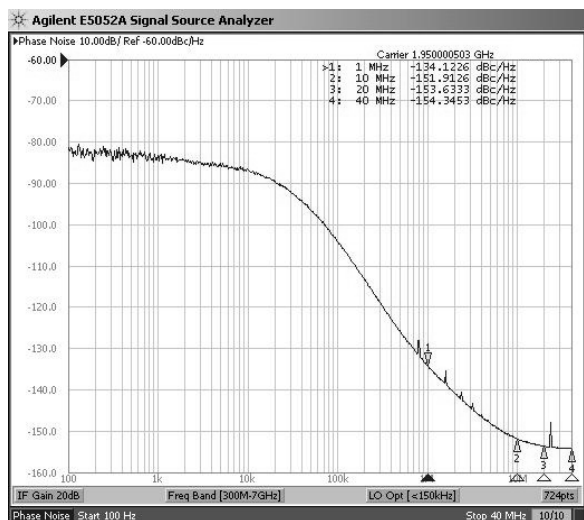

Figure 10. VCO B (Divider by 2 output) closed loop phase noise

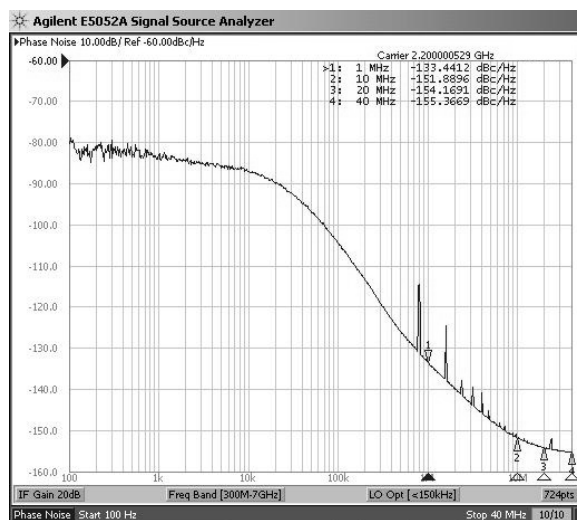

Figure 9. VCO A (Divider by 4 output) closed loop phase noise

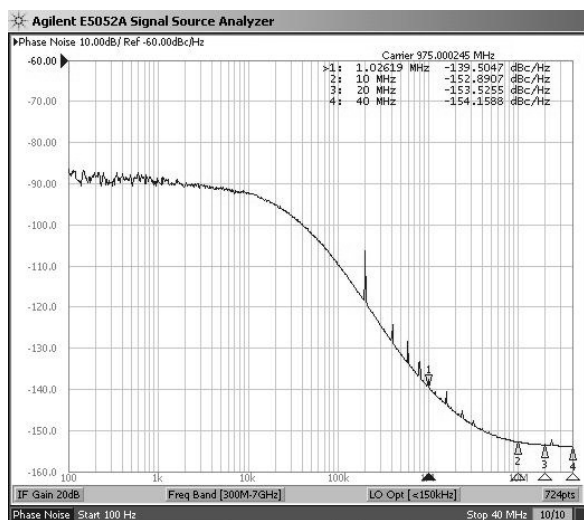
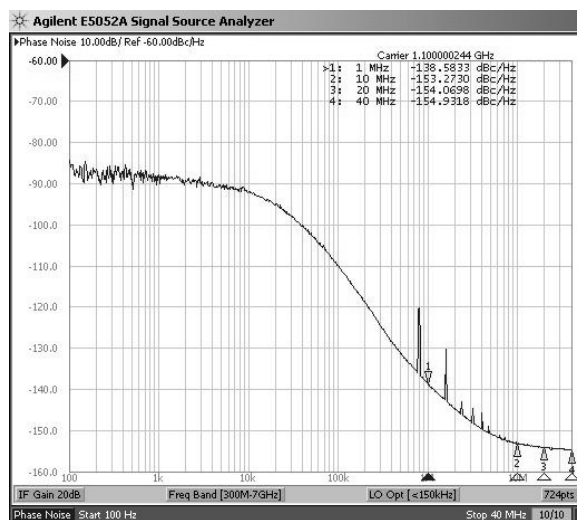

Figure 11. VCO B (Divider by 4 output) closed loop phase noise



## 6 General Description

The block diagram of Figure 2 shows the different blocks, which have been integrated to achieve an integer-N PLL frequency synthesizer.

The STW81100 consists of 2 internal low-noise VCOs with buffer blocks, a divider by 2, a divider by 4, a low-noise PFD (Phase Frequency Detector), a precise charge pump, a 9-bit programmable reference divider, two programmable counters and a dual-modulus prescaler.

The A-counter (6 bits) and B counter (9 bits) counters, in conjunction with the dual modulus prescaler P/P+1 (64/65), implement an N integer divider, where  $N = B \cdot P + A$ .

The division ratio of both reference and VCO dividers is controlled through an I<sup>2</sup>C bus interface.

All devices operate with a power supply of 3.3 V and can be powered down when not in use.

## 7 Circuit Description

### 7.1 Reference input stage

The reference input stage is shown in Figure 12. The resistor network feeds a DC bias at the Fref input while the inverter used as the frequency reference buffer is AC coupled.

Figure 12. Reference Frequency Input Buffer

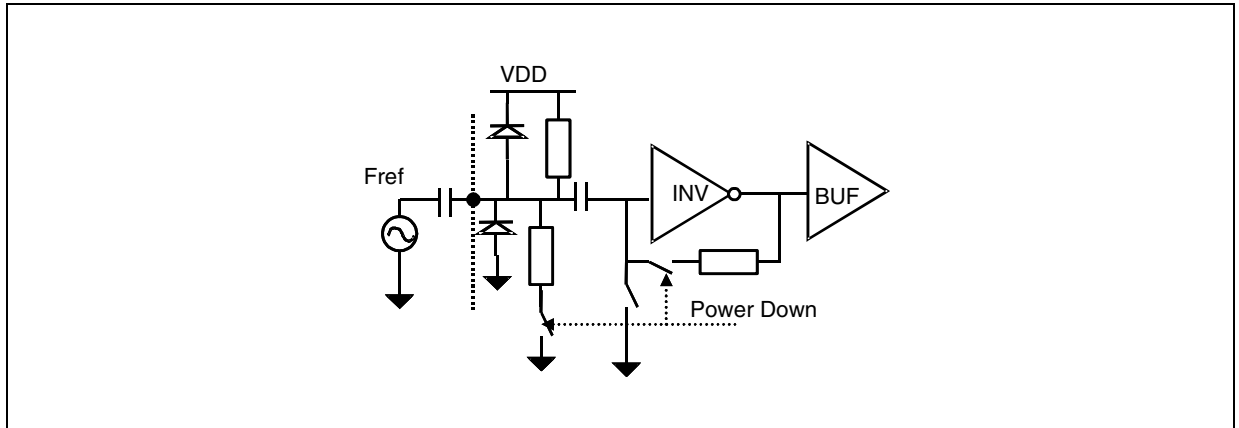

### 7.2 Reference Divider

The 9-bit programmable reference counter allows the input reference frequency to be divided to produce the input clock to the PFD. The division ratio is programmed through the I<sup>2</sup>C bus interface.

### 7.3 Prescaler

The dual-modulus prescaler 64/65 takes the CML clock from the VCO buffer and divides it down to a manageable frequency for the CMOS A and B counters. It is based on a synchronous 4/5 core which division ratio depends on the state of the modulus input.

### 7.4 A and B Counters

The A (6 bits) and B (9 bits) counters, in conjunction with the dual modulus prescaler make it possible to generate output frequencies which are spaced only by the reference frequency divided by the reference division ratio. Thus, the division ratio and the VCO output frequency are given by these formulas:

$$N = B \times P + A$$

$$F_{VCO} = \frac{(B \cdot P + A) \cdot F_{ref}}{R}$$

where:

- FVCO: output frequency of VCO.
- P: modulus of dual modulus prescaler.
- B: division ratio of the main counter.
- A: division ratio of the swallow counter.
- Fref: input reference frequency.
- R: division ratio of reference counter.
- N: division ratio of PLL

For a correct work of the VCO divider, B must be strictly higher than A. A can take any value ranging from 0 to 63. The range of the N number can vary from 4096 to 32767.

**Figure 13. VCO Divider Diagram**

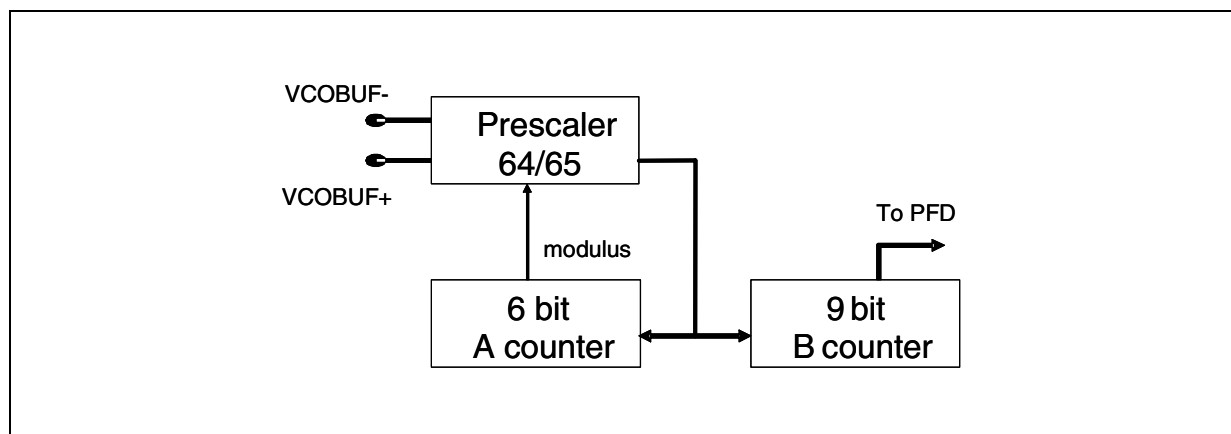

### 7.5 Phase frequency detector (PFD)

The PFD takes inputs from the reference and the VCO dividers and produces an output proportional to the phase error. The PFD includes a delay gate that controls the width of the anti-backlash pulse. This pulse ensures that there is no dead zone in the PFD transfer function.

Figure 6 is a simplified schematic of the PFD.

**Figure 14. PDF Diagram**

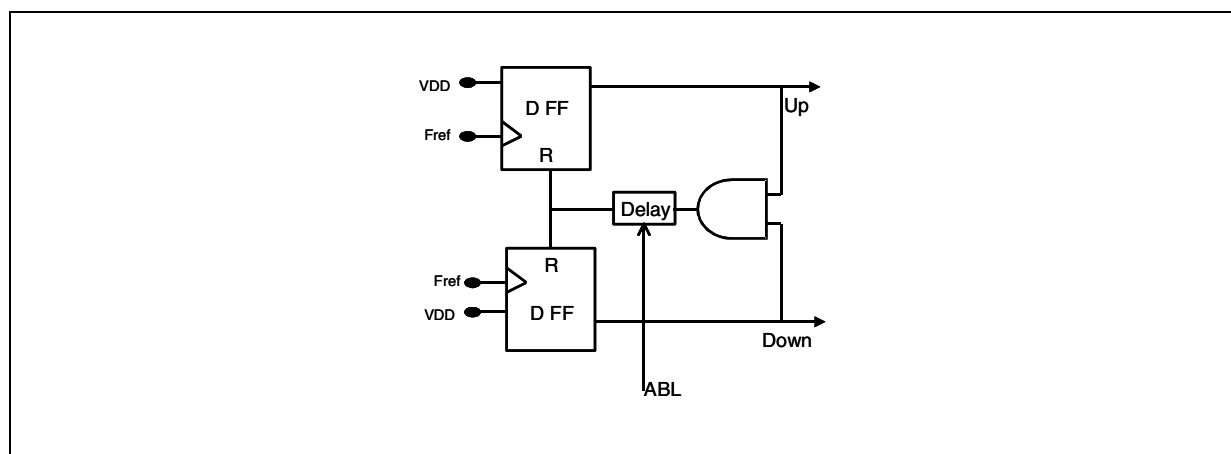

**7.6 Lock Detect**

This signal indicates that the difference between rising edges of both UP and DOWN PFD signals is found to be shorter than the fixed delay (roughly 5 ns). Lock Detect signal is high when the PLL is locked.

When Power Down is activated, Lock Detect is let to high level (Lock Detect consumes current only during PLL transients).

**7.7 Change Pump**

This block drives two matched current sources, I<sub>up</sub> and I<sub>down</sub>, which are controlled respectively by UP and DOWN PFD outputs. The nominal value of the output current is controlled by an external resistor (to be connected to the REXT input pin) and a selection among 8 by a 3 bit word.

The minimum value of the output current is:  $I_{MIN} = 2 \cdot VBG / REXT$  (VBG ~ 1.17 V)

**Table 8. Current Value vs Selection**

CPSEL2	CPSEL1	CPSEL0	Current	Value for REXT=9.1 KΩ
0	0	0	I <sub>MIN</sub>	0.25 mA
0	0	1	2*I <sub>MIN</sub>	0.50 mA
0	1	0	3*I <sub>MIN</sub>	0.75 mA
0	1	1	4*I <sub>MIN</sub>	1.00 mA
1	0	0	5*I <sub>MIN</sub>	<b>1.25 mA</b>
1	0	1	6*I <sub>MIN</sub>	1.50 mA
1	1	0	7*I <sub>MIN</sub>	1.75 mA
1	1	1	8*I <sub>MIN</sub>	2.00 mA

Note: The current is output on pin ICP. During the VCO auto calibration, ICP and VCTRL pins are forced to VDD/2.

**Figure 15. Loop Filter Connection**

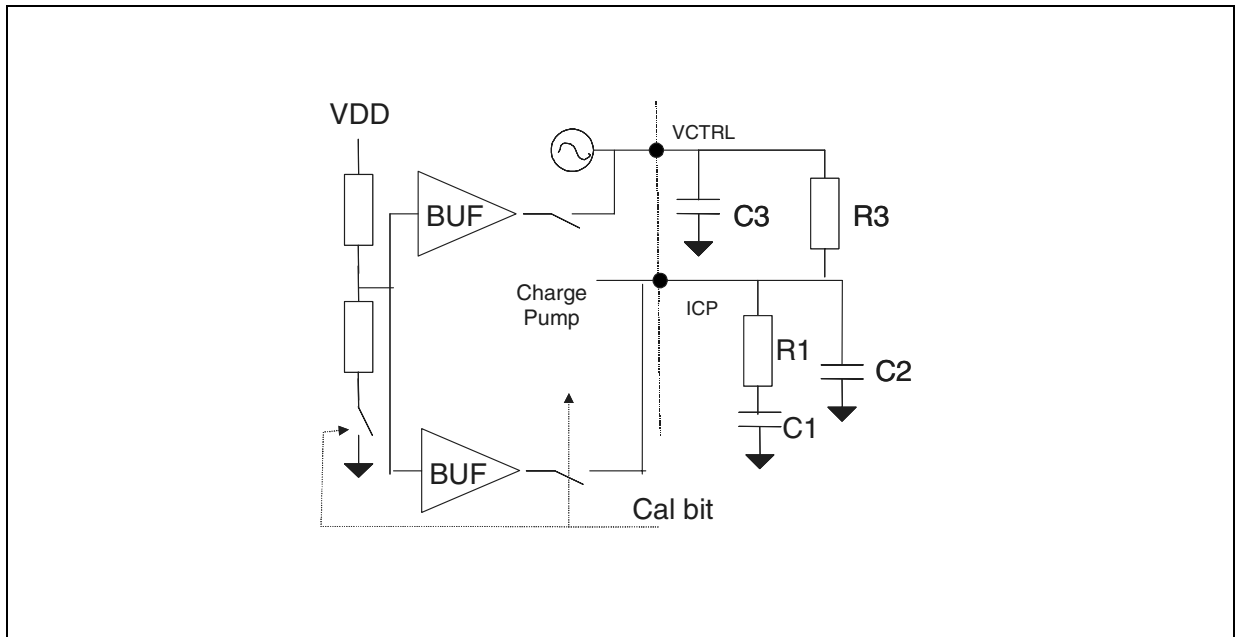

## 7.8 Voltage Controlled Oscillators

### 7.8.1 VCO Selection

Within STW81100 two low-noise VCOs are integrated to cover a wide band from 3280MHz to 4400MHz (direct output), from 1640MHz to 2200MHz (selecting divider by 2) and from 820MHz to 1100MHz (selecting divider by 4).

VCO A frequency range 3280MHz-3900MHz

VCO B frequency range 3800MHz-4400MHz

### 7.8.2 VCO Frequency Calibration

Both VCOs can operate on 32 frequency ranges that are selected by adding or subtracting capacitors to the resonator. These frequency ranges are intended to cover the wide band of operation and compensate for process variation on the VCO center frequency.

An automatic selection of the range is performed when the bit SERCAL rises from “0” to “1”. The charge pump is inhibited and the pins ICP & VCTRL are at VDD/2 volts.

Then the ranges are tested to select the one which with this VCO input voltage is the nearest to the desired output frequency ( $F_{out} = N \cdot F_{ref} / R$ ). When this selection is achieved the signal ENDCALB (which means End of Calibration) falls to “0”, then the charge pump is enabled again and SERCAL should be reset to “0” before the next channel step.

The PLL has just to perform fine adjustment around VDD/2 on the loop filter to reach  $F_{out}$ , which enables a fast settle.

**Figure 16. VCO Sub-Bands Frequency Characteristics**

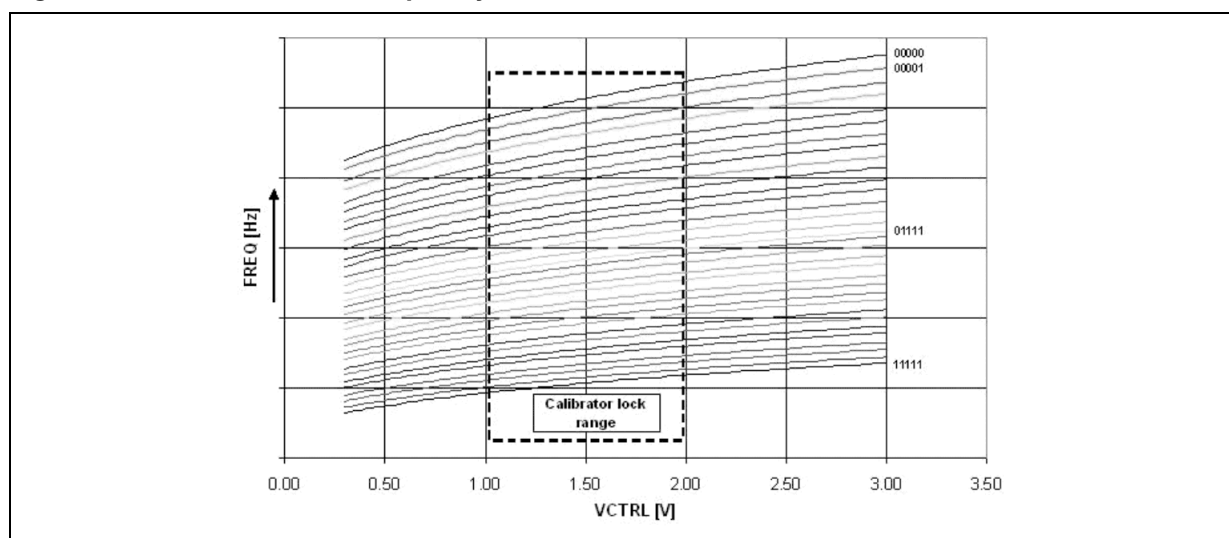

The SERCAL bit should be set to “1” at each division ratio change. It should be noted that in order to reset the autocalibrator State Machine after a power-up, and anyway before the first calibration, the INITCAL bit should be set to “1” and back to “0” (this operation is automatically performed by the Power On Reset circuitry). The calibration takes approximately 7 periods of the Comparison Frequency.

The maximum allowed  $f_{comp}$  to perform the calibration process is 1 MHz. Using an higher  $f_{comp}$  the following procedure should be adopted:

1. Calibrate the VCO at the desired frequency with an  $f_{comp}$  less than 1 MHz
2. Set the A, B and R dividers ratio for the desired  $f_{comp}$

### 7.8.3 VCO Voltage Amplitude Control

The bits A0 and A1 control the voltage swing of the VCO. The following table gives the voltage level expected on the resonator nodes.

Table 9.

Code A[1:0]	Differential output voltage (Vp)
00	1.1
01	1.3
10	1.9
11	2.1

## 8 I<sup>2</sup>C bus interface

Data transmission from microprocessor to the STW81100 takes place through the 2 wires (SDA and SCL) I<sup>2</sup>C-BUS interface. The STW81100 is always a slave device.

The I<sup>2</sup>C-bus protocol defines any device that sends data on to the bus as a transmitter and any device that reads the data as receiver. The device that controls the data transfer is known as the Master and the others as the slave. The master will always initiate the transfer and will provide the serial clock for synchronization.

### 8.1 General Features

#### 8.1.1 Power ON Reset

The device at Power ON is able to configure itself to a fixed configuration, with all programmable bits set to factory default setting.

#### 8.1.2 Data Validity

Data changes on the SDA line must only occur when the SCL is LOW. SDA transitions while the clock is HIGH are used to identify START or STOP condition.

Figure 17.

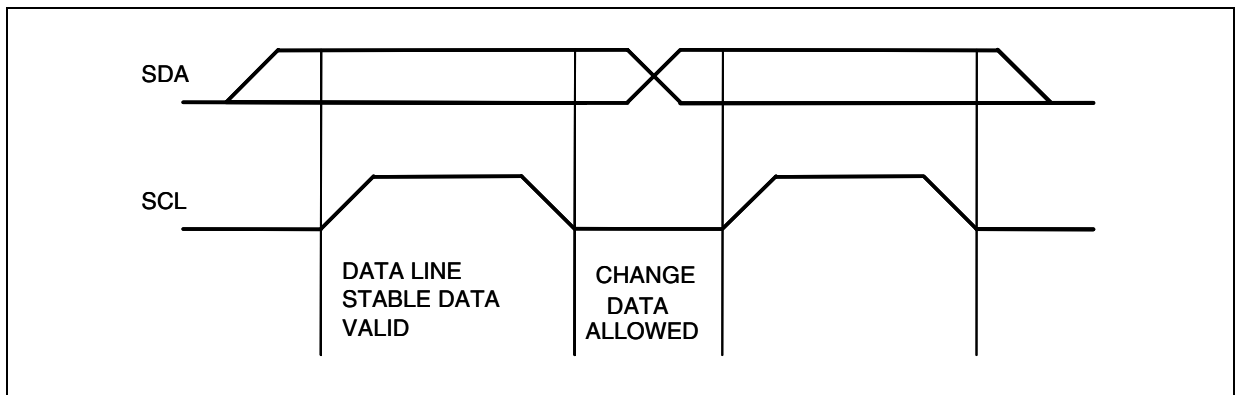

#### 8.1.3 START condition

A Start condition is identified by a HIGH to LOW transition of the data bus SDA while the clock signal SCL is stable in the HIGH state. A Start condition must precede any command for data transfer.

### 8.1.4 STOP condition

A LOW to HIGH transition of the data bus SDA identifies start while the clock signal SCL is stable in the HIGH state. A STOP condition terminates communications between the STW81100 and the Bus Master.

Figure 18.

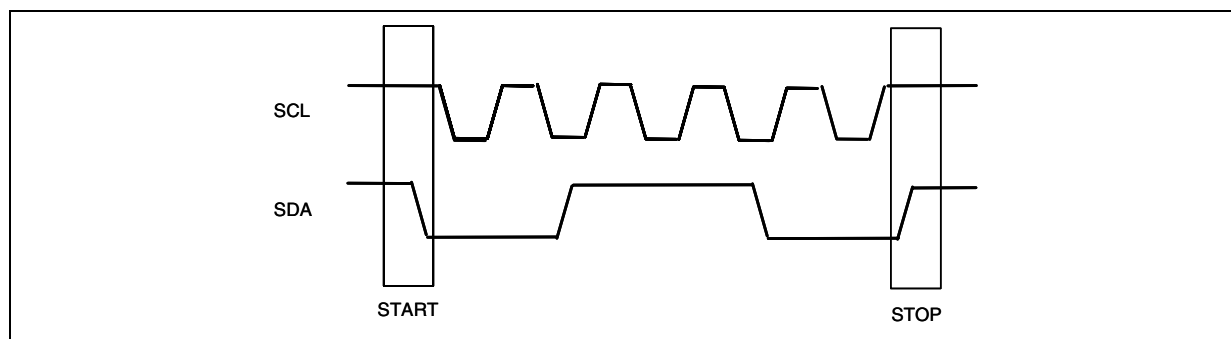

### 8.1.5 Byte format and acknowledge

Every byte transferred on the SDA line must contain bits. Each byte must be followed by an acknowledge bit. The MSB is transferred first.

An acknowledge bit is used to indicate a successful data transfer. The bus transmitter, either master or slave, will release the SDA bus after sending 8 bits of data. During the 9th clock pulse the receiver pulls the SDA low to acknowledge the receipt of 8 bits data.

Figure 19.

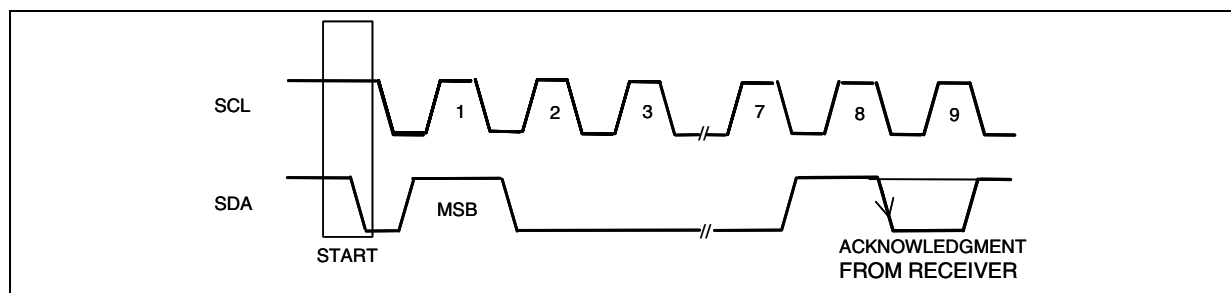

### 8.1.6 Device addressing

To start the communication between the Master and the STW81100, the master must initiate with a start condition. Following this, the master sends onto the SDA line 8 bits (MSB first) corresponding to the device select address and read or write mode.

The first 7 MSB's are the device address identifier, corresponding to the I<sup>2</sup>C-Bus definition. For the STW81100 the address is set as "1100A<sub>2</sub>A<sub>1</sub>A<sub>0</sub>", 3bits programmable. The 8th bit (LSB) is the read or write operation bit (RW; set to 1 in read mode and to 0 in write mode).

After a START condition the STW81100 identifies on the bus the device address and, if matched, it will acknowledge the identification on SDA bus during the 9th clock pulse.

### 8.1.7 Single-byte write mode

Following a START condition the master sends a device select code with the RW bit set to 0. The STW81100 gives an acknowledge and waits for the internal sub-address (1 byte). This byte provides access to any of the internal registers.

After the reception of the internal byte sub-address the STW81100 again responds with an acknowledge. A single byte write to sub-address 00H would affect DATA\_OUT[119:112], so a single byte write with sub-address 07H would affect DATA\_OUT[63:56] and so on.

Table 10.

S	1100A <sub>2</sub> A <sub>1</sub> A <sub>0</sub>	0	ack	sub-address byte	ack	DATA IN	ack	P
---	--	---	-----	------------------	-----	---------	-----	---

**8.1.8 Multi-byte write mode**

The multi-byte write mode can start from any internal address. The master sends the data bytes and each one is acknowledged. The master terminates the transfer by generating a STOP condition.

The sub-address decides the starting byte. A multi byte with sub-address 07H and 5 DATA\_IN byte would affect the bytes starting from DATA\_OUT[63:56] to DATA\_OUT[31:24] and so on.

Table 11.

S	1100A <sub>2</sub> A <sub>1</sub> A <sub>0</sub>	0	ack	sub-address byte	ack	DATA IN	ack	...	DATA IN	ack	P
---	--	---	-----	------------------	-----	---------	-----	-----	---------	-----	---

**8.1.9 Current Byte Address Read**

In the current byte address read mode, following a START condition, the master sends the device address with the rw bit set to 1 (No sub-address is needed as there is only 1 byte read register). The STW81100 acknowledges this and outputs the data byte. The master does not acknowledge the received byte, but terminates the transfer with a STOP condition.

Table 12.

S	1100A <sub>2</sub> A <sub>1</sub> A <sub>0</sub>	0	ack	sub-address byte	ack	DATA IN	ack	...	DATA IN	ack	P
---	--	---	-----	------------------	-----	---------	-----	-----	---------	-----	---

**8.2 Timing Specification**

Figure 20. Data and clock

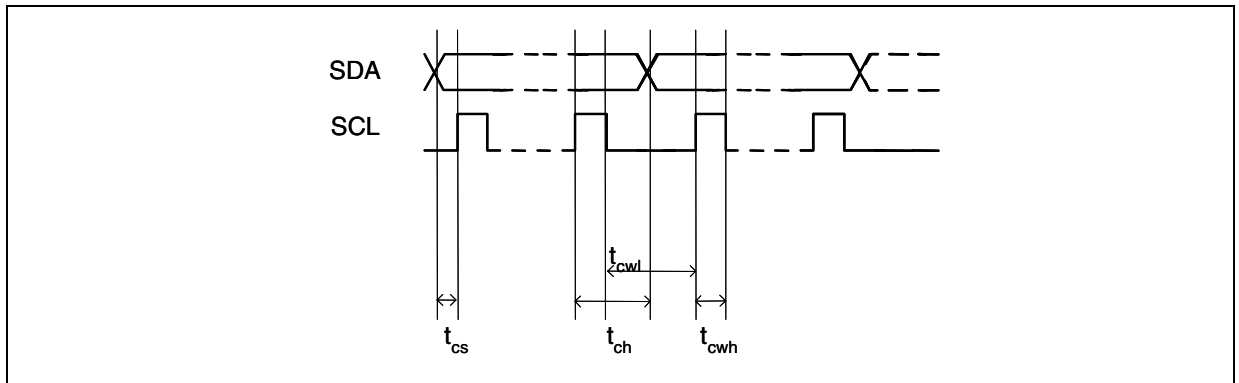

Table 13.

Symbol	Parameter	Minimum time (ns)
$T_{cs}$	Data to clock set up time	2
$T_{ch}$	Data to clock hold time	2
$T_{cwh}$	Clock pulse width high	10
$T_{cwl}$	Clock pulse width low	5



Figure 21. Start and Stop

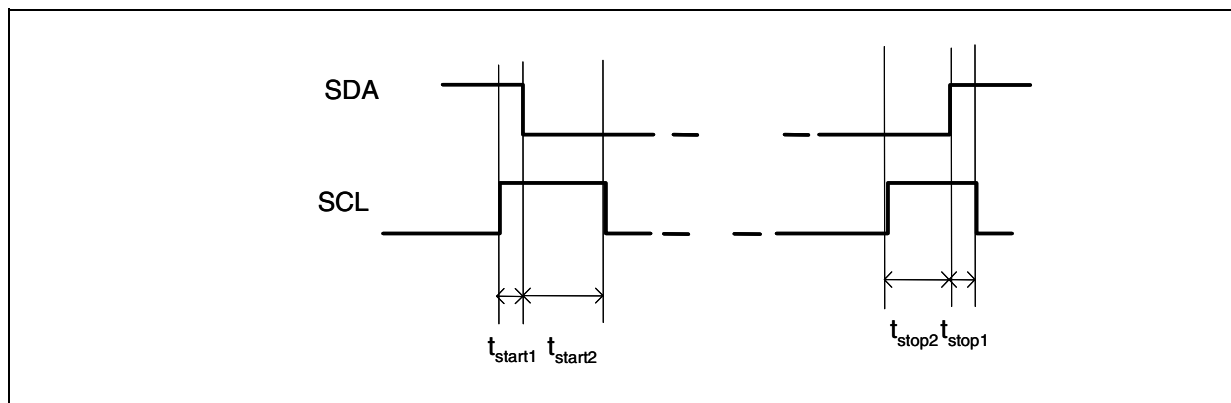

Table 14.

Symbol	Parameter	Minimum time (ns)
$T_{start1,2}$	Clock to data start time	2
$T_{stop1,2}$	Data to clock down stop time	2

Figure 22. Ack

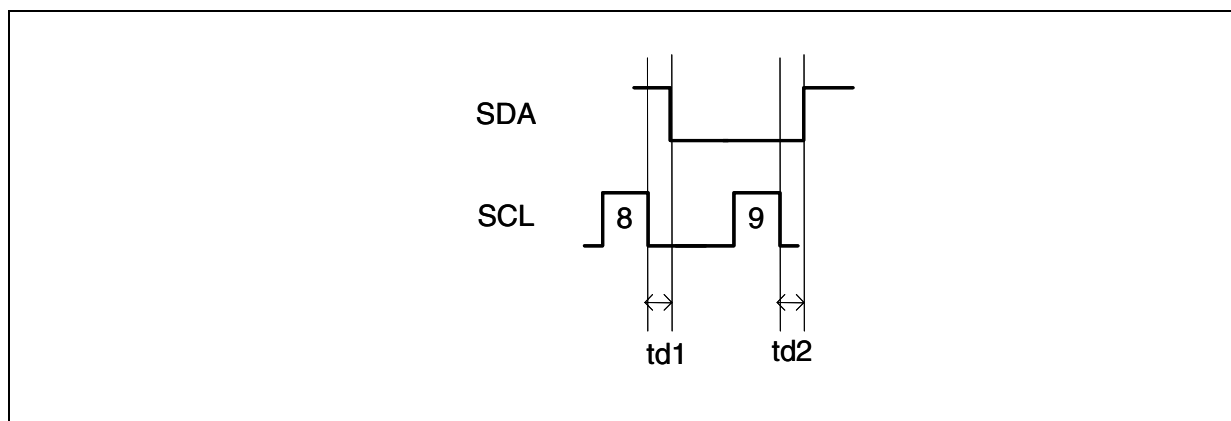

Table 15.

Symbol	Parameter	Maximum time (ns)
$T_{d1}$	Ack begin delay	2
$T_{d2}$	Ack end delay	2

### 8.3 I<sup>2</sup>C Register

STW81100 has 6 write-only registers and 1 read-only register.

The following table gives a short description of the write-only registers list.

Table 16.

HEX CODE	DEC CODE	DESCRIPTION
0x00	0	FUNCTIONAL_MODE
0x01	1	B_COUNTER
0x02	2	A_COUNTER
0x03	3	REF_DIVIDER
0x04	4	CALIBRATION
0x05	5	CONTROL

Table 17. Functional\_Mode

MSB							LSB
b7	b6	b5	b4	b3	b2	b1	b0
PD7	PD6	PD5	PD4	PD3	PD2	PD1	PD0

FUNCTIONAL\_MODE register is used to select different functional mode for the STW81100 synthesizer according to the following table:

Table 18.

Decimal value	Description
0	Power down mode
1	Enable VCO A, output frequency divided by 2
2	Enable VCO B, output frequency divided by 2
3	Enable external VCO, output frequency divided by 2
4	Enable VCO A, output frequency divided by 4
5	Enable VCO B, output frequency divided by 4
6	Enable external VCO, output frequency divided by 4
7	Enable VCO A, direct output
8	Enable VCO B, direct output
9	Enable external VCO, direct output

Table 19. B\_COUNTER

MSB							LSB
b7	b6	b5	b4	b3	b2	b1	b0
B8	B7	B6	B5	B4	B3	B2	B1

B[8:1] Counter value (bit B0 in the next register)

**Table 20. A\_COUNTER**

MSB							LSB
b7	b6	b5	b4	b3	b2	b1	b0
B0	A5	A4	A3	A2	A1	A0	RS

Bit B0 for B Counter, A Counter value and bit R8 for Reference divider.

**Table 21. REF\_DIVIDER**

MSB							LSB
b7	b6	b5	b4	b3	b2	b1	b0
R7	R6	R5	R4	R3	R2	R1	R0

Reference Clock divider ratio R[7:0] (bit R8 in the previous register).

The LO output frequency is programmed by setting the proper value for A,B and R according to the following formula:

$$F_{OUT} = D_R \cdot (B \cdot 64 + A) \cdot \frac{F_{REF\_CLK}}{R}$$

where  $D_R$  equals

{	1	for Direct Output
	0.5	for Output Divided by 2
	0.25	for Output Divided by 4

**Table 22. Calibration**

MSB							LSB
b7	b6	b5	b4	b3	b2	b1	b0
INIT CAL	SER CAL	SEL EXT CAL	CAL 0	CAL 1	CAL 2	CAL 3	CAL 4

This register controls VCO calibrator.

INITCAL: resets the auto-calibrator State Machine (writing to “1” and back to “0”)

SERCAL: at “1” starts the VCO auto-calibration (should be reset to “0” at the end of calibration)

SELEXTCAL: at “1” selects control word EXTAL[4:0] for the VCO

EXTCAL[4:0]: control word for the VCO

**Table 23. CONTROL**

b7	b6	b5	b4	b3	b2	b1	b0
PLL_A0	PLL_A1	CP SEL 0	CP SEL 1	CP SEL 2	NA	NA	NA

The CONTROL register is used to set the VCO output voltage amplitude and the Charge Pump Current.

PLL\_A[1:0]: VCO amplitude

CPSEL[2:0]: Charge Pump output current

**Table 24. READ-ONLY REGISTER**

b7	b6	b5	b4	b3	b2	b1	b0
ILLEG AL_SUBADD0	END CALB	LOCK_DET	INT CAL4	INT CAL3	INT CAL2	INT CAL1	INT CAL0

This register is automatically addressed in the 'current byte address read mode'.

ILLEGAL\_SUBADD: gives "1" if the sub-address value is not correct

ENDCALB: at "0" means end of auto-calibration phase

LOCK\_DET: "1" when PLL is locked

INTCAL[4:0]: internal value of the VCO control word

**Figure 23. Application Diagram**

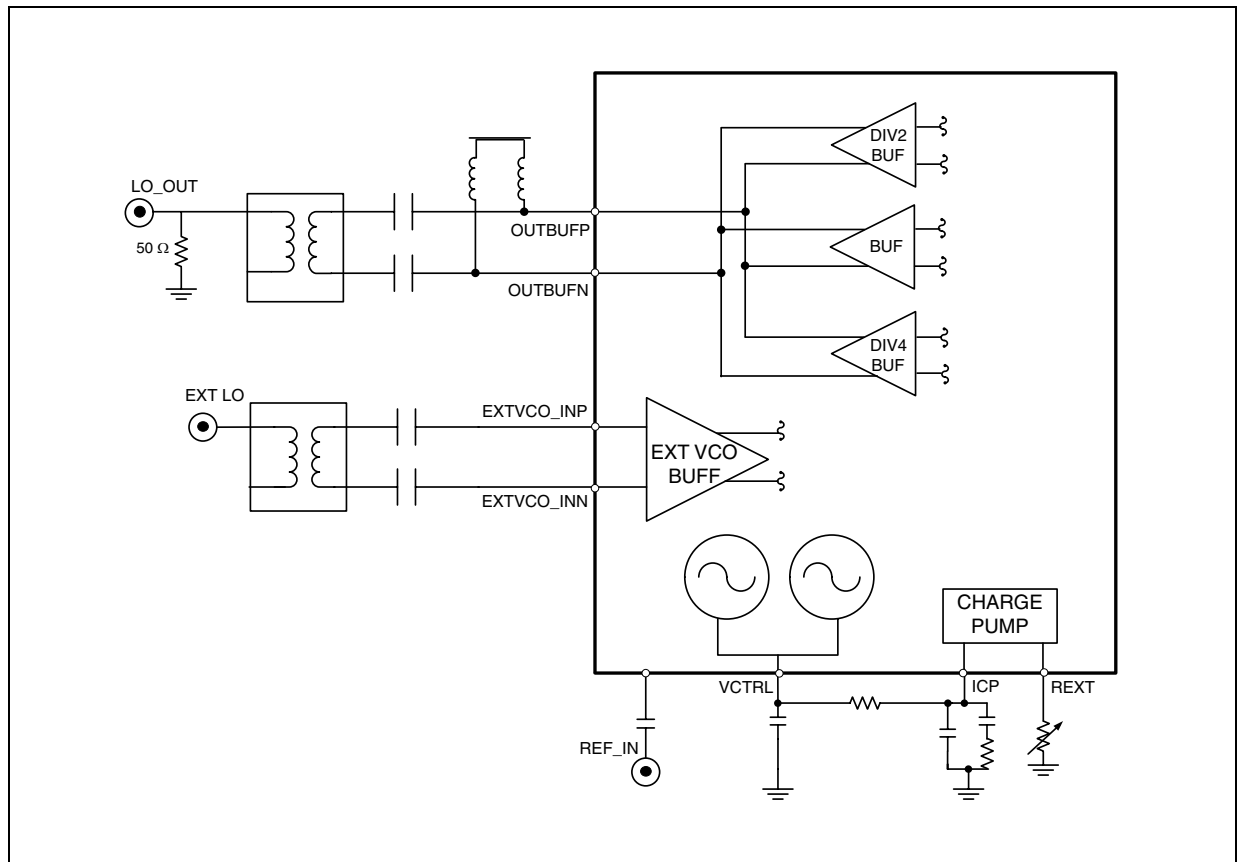

## 9 Package Information

Figure 24. VFQFPN28 Mechanical Data & Package Dimensions

REF.	mm			inch		
	MIN.	TYP.	MAX.	MIN.	TYP.	MAX.
A	0.800	0.900	1.000	0.031	0.035	0.039
A1		0.020	0.050		0.0008	0.0019
A2		0.650	1.000		0.025	0.039
A3		0.200			0.0078	
b	0.180	0.250	0.300	0.007	0.0098	0.012
D	4.850	5.000	5.150	0.191	0.197	0.203
D1		4.750			0.187	
D2	1.250	2.700	3.250	0.049	0.106	0.128
E	4.850	5.000	5.150	0.191	0.197	0.203
E1		4.750			0.187	
E2	1.250	2.700	3.250	0.049	0.106	0.128
e		0.500			0.020	
L	0.350	0.550	0.750	0.014	0.022	0.029
P			0.60			0.0236
K			14°			14°
ddd			0.080			0.003

Notes: 1) VFQFPN stands for Thermally Enhanced Very thin Fine pitch Quad Packages No lead.  
Very thin: A = 1.00 Max.

2) The pin #1 identifier must be existed on the top surface of the package by using indentation mark or other feature of package body.  
Exact shape and size of this feature is optional.

### OUTLINE AND MECHANICAL DATA

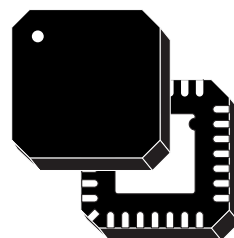

### VFQFPN-28 (5x5x1.0mm) Very Fine Quad Flat Package No lead

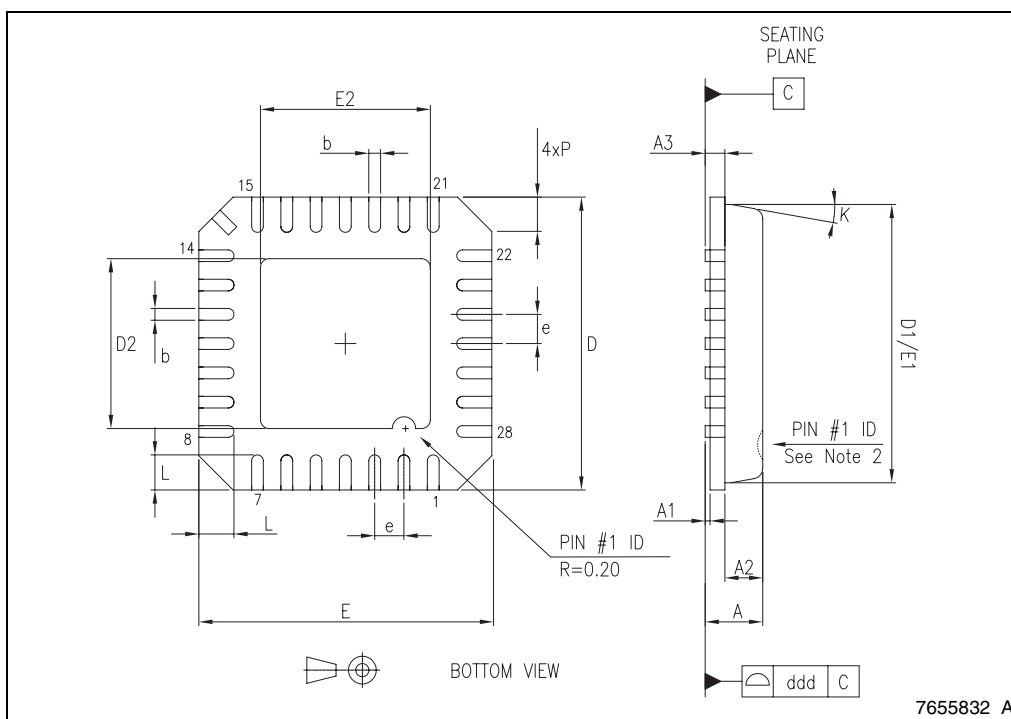

## 10 Revision History

**Table 25. Revision History**

Date	Revision	Description of Changes
March 2005	1	First Issue
April 2005	2	Changed the maturity from Preliminary to Final datasheet. Modified sections: 1, 2, 4 (Tables 6, 7). Added new section 5 "Typical Performance Characteristics". Modified sub-section 7.8.2 "VCO Frequency Calibration". Changed "Package Informations".

Information furnished is believed to be accurate and reliable. However, STMicroelectronics assumes no responsibility for the consequences of use of such information nor for any infringement of patents or other rights of third parties which may result from its use. No license is granted by implication or otherwise under any patent or patent rights of STMicroelectronics. Specifications mentioned in this publication are subject to change without notice. This publication supersedes and replaces all information previously supplied. STMicroelectronics products are not authorized for use as critical components in life support devices or systems without express written approval of STMicroelectronics.

The ST logo is a registered trademark of STMicroelectronics.  
All other names are the property of their respective owners

© 2005 STMicroelectronics - All rights reserved

STMicroelectronics group of companies

Australia - Belgium - Brazil - Canada - China - Czech Republic - Finland - France - Germany - Hong Kong - India - Israel - Italy - Japan -  
Malaysia - Malta - Morocco - Singapore - Spain - Sweden - Switzerland - United Kingdom - United States of America

[www.st.com](http://www.st.com)