

TOSHIBA TRANSISTOR SILICON NPN TRIPLE DIFFUSED TYPE

# 2SD1313

HIGH POWER AMPLIFIER APPLICATIONS.  
HIGH POWER SWITCHING APPLICATIONS.

INDUSTRIAL APPLICATIONS  
Unit in mm

- High Power Dissipation :  $P_C=200W$  ( $T_c=25^\circ C$ )
- High Collector Current :  $I_C=25A$  (DC)
- High Speed Switching :  $t_f=0.5\mu s$  (Typ.) ( $I_C=15A$ )
- Low Saturation Voltage :  $V_{CE(sat)}=1.0V$  (Max.) ( $I_C=15A$ )

MAXIMUM RATINGS ( $T_a = 25^\circ C$ )

| CHARACTERISTIC                                      | SYMBOL    | RATING   | UNIT       |
|---|-----------|----------|------------|
| Collector-Base Voltage                              | $V_{CB0}$ | 800      | V          |
| Collector-Emitter Voltage                           | $V_{CEO}$ | 350      | V          |
| Emitter-Base Voltage                                | $V_{EBO}$ | 7        | V          |
| Collector Current                                   | DC        | $I_C$    | 25         |
|   | Pulse     | $I_{CP}$ | 35         |
| Base Current  | DC        | $I_B$    | 10         |
|   | Pulse     | $I_{BP}$ | 15         |
| Collector Power Dissipation<br>( $T_c=25^\circ C$ ) | $P_C$     | 200      | W          |
| Junction Temperature                                | $T_j$     | 150      | $^\circ C$ |
| Storage Temperature Range                           | $T_{stg}$ | -55~150  | $^\circ C$ |

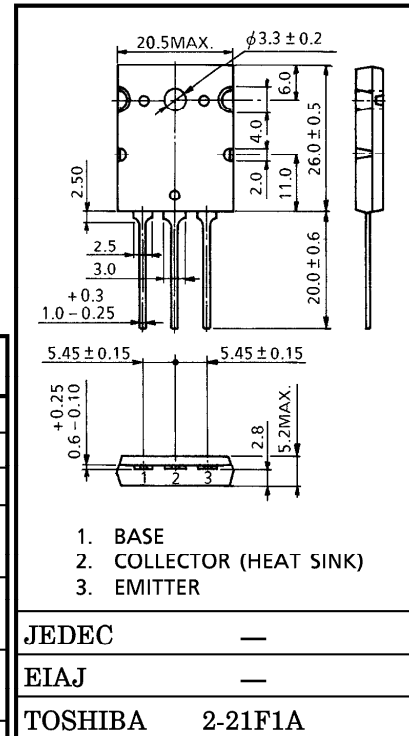

Weight : 9.75g (Typ.)

961001EAA2

● TOSHIBA is continually working to improve the quality and the reliability of its products. Nevertheless, semiconductor devices in general can malfunction or fail due to their inherent electrical sensitivity and vulnerability to physical stress. It is the responsibility of the buyer, when utilizing TOSHIBA products, to observe standards of safety, and to avoid situations in which a malfunction or failure of a TOSHIBA product could cause loss of human life, bodily injury or damage to property. In developing your designs, please ensure that TOSHIBA products are used within specified operating ranges as set forth in the most recent products specifications. Also, please keep in mind the precautions and conditions set forth in the TOSHIBA Semiconductor Reliability Handbook.

● The information contained herein is presented only as a guide for the applications of our products. No responsibility is assumed by TOSHIBA CORPORATION for any infringements of intellectual property or other rights of the third parties which may result from its use. No license is granted by implication or otherwise under any intellectual property or other rights of TOSHIBA CORPORATION or others.

● The information contained herein is subject to change without notice.

ELECTRICAL CHARACTERISTICS (Ta = 25°C)

| CHARACTERISTIC                       |              | SYMBOL                | TEST CONDITION   | MIN. | TYP. | MAX. | UNIT |
|--------------------------------------|--------------|-----------------------|--|------|------|------|------|
| Collector Cut-off Current            |              | ICBO                  | V <sub>CB</sub> = 800V, I <sub>E</sub> = 0   | —    | —    | 1    | mA   |
| Emitter Cut-off Current              |              | IEBO                  | V <sub>EB</sub> = 7V, I <sub>C</sub> = 0   | —    | —    | 1    | mA   |
| Collector-Emitter Breakdown Voltage  |              | V (BR) CEO            | I <sub>C</sub> = 10mA, I <sub>B</sub> = 0  | 350  | —    | —    | V    |
| DC Current Gain                      |              | h <sub>FE</sub> (1)   | V <sub>CE</sub> = 5V, I <sub>C</sub> = 1A  | 15   | —    | —    |      |
|                                      |              | h <sub>FE</sub> (2)   | V <sub>CE</sub> = 5V, I <sub>C</sub> = 25A   | 6    | —    | —    |      |
| Collector-Emitter Saturation Voltage |              | V <sub>CE</sub> (sat) | I <sub>C</sub> = 15A, I <sub>B</sub> = 3A  | —    | —    | 1.0  | V    |
| Base-Emitter Saturation Voltage      |              | V <sub>BE</sub> (sat) | I <sub>C</sub> = 15A, I <sub>B</sub> = 3A  | —    | —    | 1.7  | V    |
| Collector Output Capacitance         |              | C <sub>ob</sub>       | V <sub>CB</sub> = 50V, I <sub>E</sub> = 0, f = 1MHz  | —    | 170  | —    | pF   |
| Transition Frequency                 |              | f <sub>T</sub>        | V <sub>CE</sub> = 10V, I <sub>C</sub> = 1A   | —    | 6    | —    | MHz  |
| Switching Time                       | Turn-on Time | t <sub>on</sub>       | <p>V<sub>CC</sub> = 200V<br/> <math>I_C</math><br/> <math>I_{B1}</math> INPUT <math>I_{B1}</math><br/> <math>I_{B2}</math> <math>I_{B2}</math><br/>         OUTPUT<br/> <math>I_C = 15A, I_{B1} = -I_{B2} = 3A,</math><br/>         DUTY CYCLE &lt; 1%</p> | —    | 0.8  | —    | μs   |
|                                      | Storage Time | t <sub>stg</sub>      |  | —    | 3.0  | —    |      |
|                                      | Fall Time    | t <sub>f</sub>        |  | —    | —    | 0.5  |      |

**SWITCHING APPLICATIONS**

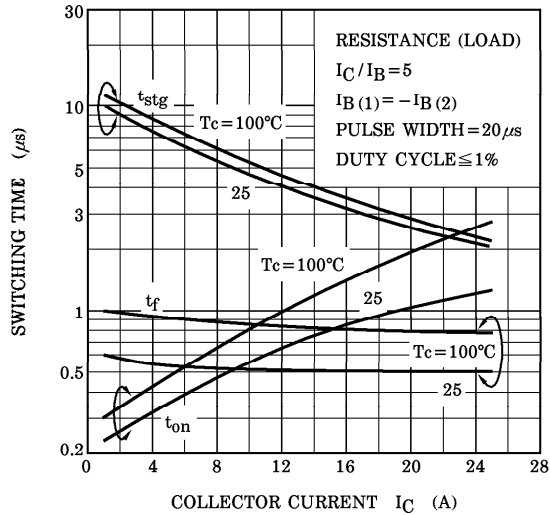

**hFE -  $I_C$**

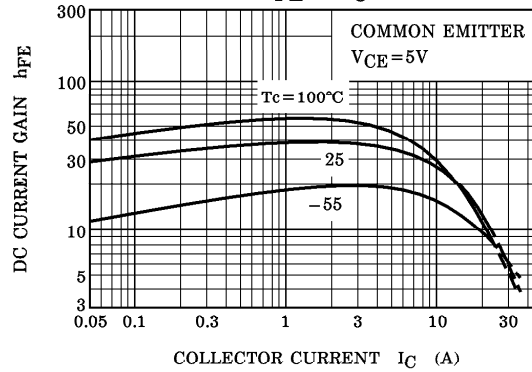

**$I_C - V_{CE}$**

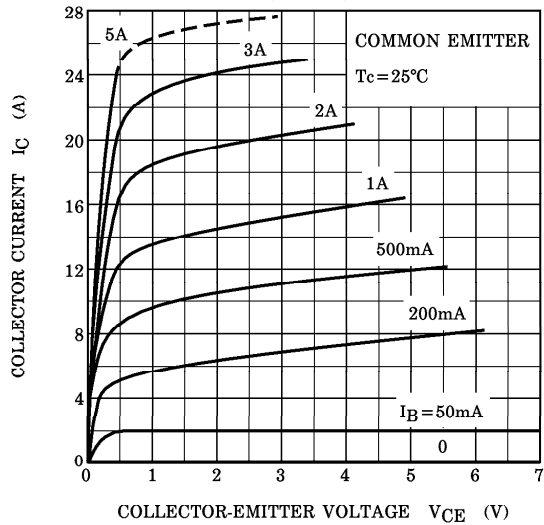

**$V_{CE}(\text{sat}) - I_C$**

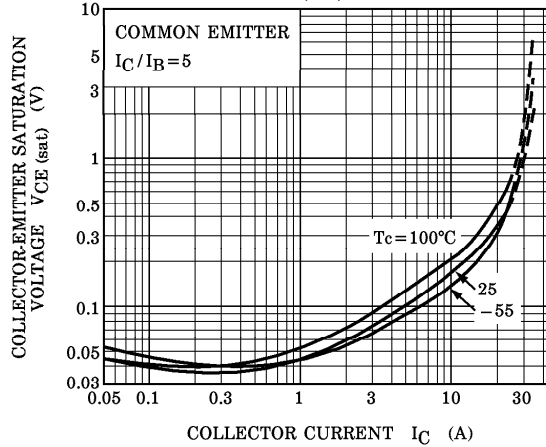

**$V_{BE}(\text{sat}) - I_C$**

