

MICRO ELECTRONICS

MSB31TK-1
**ULTRA HIGH
 BRIGHTNESS
 RED LED LAMP**

DESCRIPTION

MSB31TK-1 is an ultra high brightness output red GaAlAs LED lamp encapsulated in a 3mm diameter clear transparent lens.

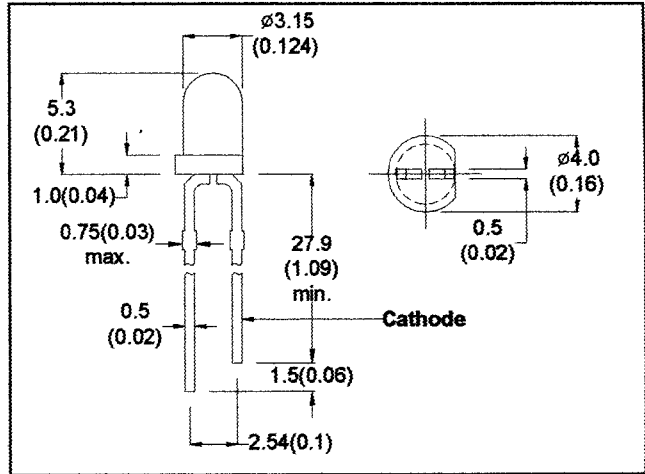

- All Dimension in mm (inch)
- No Scale
- Tol : +/- 0.3mm

ABSOLUTE MAXIMUM RATINGS

Power Dissipation @Ta=25°C	100mW
Forward Current, DC (IF)	40mA
Reverse Voltage	5V
Operating & Storage Temperature Range	-55 to +100°C
Lead Soldering Temperature (1/16" from body)	260°C for 5 sec.

ELECTRO-OPTICAL CHARACTERISTICS (Ta=25°C)

PARAMETER	SYMBOL	MIN	TYP	MAX	UNIT	CONDITIONS
Forward Voltage	VF		1.8	2.4	V	IF=20mA
Reverse Breakdown Voltage	BVR	5			V	IR=100μA
Luminous Intensity	IV	90	150		mcd	IF=20mA
Peak Wavelength	λp		660		nm	IF=20mA
Spectral Line Half Width	Δλ		20		nm	IF=20mA
Viewing Angle	2θ 1/2		45		degree	IF=20mA

Page 1 of 2

MICRO ELECTRONICS LTD.

38, Hung To Road, Microtron Building, Kwun Tong, Kowloon, Hong Kong.
 Kwun Tong P.O. Box 69477 Hong Kong. Fax No. 2341 0321 Telex:43510 Micro Hx. Tel: 2343 0181-5

Aug-99

MSB31TK-1

