

## Transmission Mode Low Noise Bialkali Photocathode 28mm (1-1/8 inch) Diameter, Side-on Type

### FEATURES

- Low Dark Current
- Low Dark Counts (R2693P)
- Wide Photocathode
- Excellent Spatial Uniformity
- Fast Time Response

### APPLICATIONS

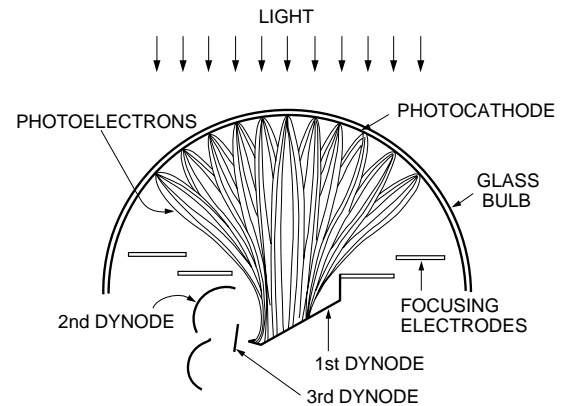
- Fluorescence Detector
- Chemiluminescence Detector
- Raman Spectroscopy
- Emission Spectroscopy
- Light Scattering Detector



### GENERAL

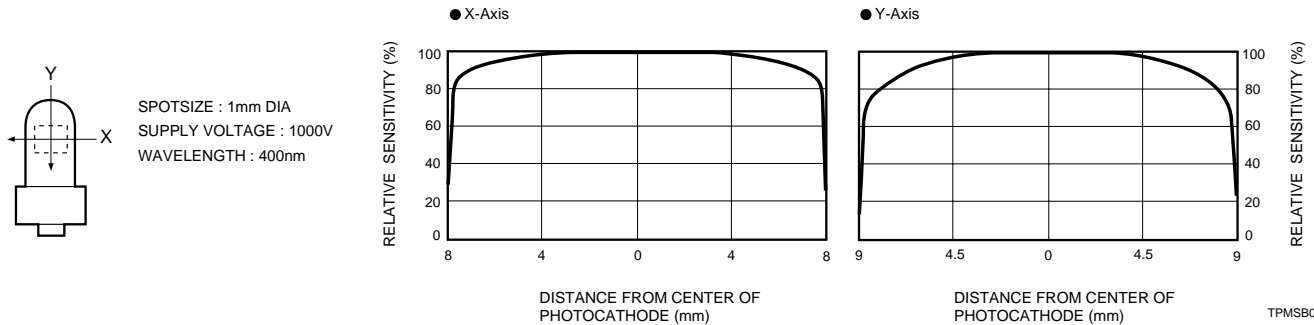
Parameter	Description	Unit
Spectral Response	185 to 650	nm
Wavelength of Maximum Response	375	nm
Photocathode Material	Low noise bialkali	—
Minimum Effective Area	16(H) × 18(W)	mm
Window Material	UV glass	—
Dynode Structure	Circular-cage	—
Number of Stages	9	—
Direct Interelectrode Capacitances		
Anode to Last Dynode	1.2	pF
Anode to All Other Electrodes	3.4	pF
Base	11-pin base JEDEC No. B11-88	—
Suitable Socket	E678-11A (option)	—
Applicable Socket Assembly	E717-21 (option)	—

Figure 1: Electron Trajectories



TPMSC0003EB

Figure 2: Typical Spatial Uniformity



TPMSB0066EA

Subject to local technical requirements and regulations, availability of products included in this promotional material may vary. Please consult with our sales office.

Information furnished by HAMAMATSU is believed to be reliable. However, no responsibility is assumed for possible inaccuracies or omissions. Specifications are subject to change without notice. No patent rights are granted to any of the circuits described herein. © 1993 Hamamatsu Photonics K.K.

# PHOTOMULTIPLIER TUBES R2693, R2693P

## MAXIMUM RATINGS (Absolute Maximum Values)

Parameter		Value	Unit
Supply Voltage	Between Anode and Cathode	1250	Vdc
	Between Anode and Last Dynode	250	Vdc
Average Anode Current <sup>A</sup>		0.1	mA
Ambient Temperature		-80 to +50	°C

## CHARACTERISTICS (at 25°C)

Parameter	R2693 for General Purpose			R2693P for Photon Counting			Unit	
	Min.	Typ.	Max.	Min.	Typ.	Max.		
Cathode Sensitivity	Quantum Efficiency at 375nm	—	20.5	—	20.5	—	%	
	Luminous <sup>B</sup>	30	50	—	30	50	μA/lm	
	Radiant at 375nm (Peak)	—	62	—	—	62	mA/W	
Anode Sensitivity	Blue <sup>C</sup>	—	7.0	—	—	7.0	μA/lm-b	
	Luminous <sup>D</sup>	100	300	—	100	300	A/lm	
Gain <sup>D</sup>	Radiant at 375nm	—	3.7 × 10 <sup>5</sup>	—	—	3.7 × 10 <sup>5</sup>	A/W	
		—	6 × 10 <sup>6</sup>	—	—	6 × 10 <sup>6</sup>	—	
Anode Dark Current <sup>E</sup> (After 30min. storage in darkness)		—	0.5	5.0	—	0.1	2.0	nA
Anode Dark Counts <sup>E</sup>		—	—	—	—	15	50	cps
ENI(Equivalent Noise Input) <sup>F</sup>		—	8.6 × 10 <sup>-17</sup>	—	—	3.9 × 10 <sup>-17</sup>	—	W
Time Response <sup>D</sup>	Anode Pulse Rise Time <sup>G</sup>	—	1.2	—	—	1.2	—	ns
	Electron Transit Time <sup>H</sup>	—	18	—	—	18	—	ns
	Transit Time Spread (FWHM) <sup>J</sup>	—	1.0	—	—	1.0	—	ns
Anode Current Stability <sup>K</sup>	Current Hysteresis	—	0.5	—	—	0.5	—	%
	Voltage Hysteresis	—	1.0	—	—	1.0	—	%

## NOTES

- A: Averaged over any interval of 30 seconds maximum.  
 B: The light source is a tungsten filament lamp operated at a distribution temperature of 2856K. Supply voltage is 100 volts between the cathode and all other electrodes connected together as anode.  
 C: The value is cathode output current when a blue filter(Corning CS-5-58 polished to 1/2 stock thickness) is interposed between the light source and the tube under the same condition as Note B.  
 D: Measured with the same light source as Note B and with the voltage distribution ratio shown in Table 1 below.

**Table 1: Voltage Distribution Ratio**

● R2693	Electrodes	K	Dy1	Dy2	Dy3	....	Dy9	P
	Ratio		1	1	1	.....	1	1
● R2693P	Electrodes	K	Dy1	Dy2	Dy3	....	Dy9	P
	Ratio		2.5	1.5	1	.....	1	1

Supply Voltage : 1000Vdc, K : Cathode, Dy : Dynode, P : Anode

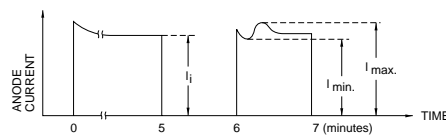
- E: Measured with the same supply voltage and voltage distribution ratio as Note D after removal of light.  
 F: ENI is an indication of the photon-limited signal-to-noise ratio. It refers to the amount of light in watts to produce a signal-to-noise ratio of unity in the output of a photomultiplier tube.

$$ENI = \frac{\sqrt{2q \cdot I_{db} \cdot G \cdot \Delta f}}{S}$$

- where  $q$  = Electronic charge ( $1.60 \times 10^{-19}$  coulomb).  
 $I_{db}$  = Anode dark current(after 30 minutes storage) in amperes.  
 $G$  = Gain.  
 $\Delta f$  = Bandwidth of the system in hertz. 1 hertz is used.  
 $S$  = Anode radiant sensitivity in amperes per watt at the wavelength of peak response.

- G: The rise time is the time for the output pulse to rise from 10% to 90% of the peak amplitude when the entire photocathode is illuminated by a delta function light pulse.  
 H: The electron transit time is the interval between the arrival of delta function light pulse at the entrance window of the tube and the time when the anode output reaches the peak amplitude. In measurement, the whole photocathode is illuminated.  
 J: Also called transit time jitter. This is the fluctuation in electron transit time between individual pulses in the single photoelectron mode, and may be defined as the FWHM of the frequency distribution of electron transit times.  
 K: Hysteresis is temporary instability in anode current after light and voltage are applied.

$$\text{Hysteresis} = \frac{I_{\max} - I_{\min}}{I_i} \times 100(\%)$$



TPMSB0002EA

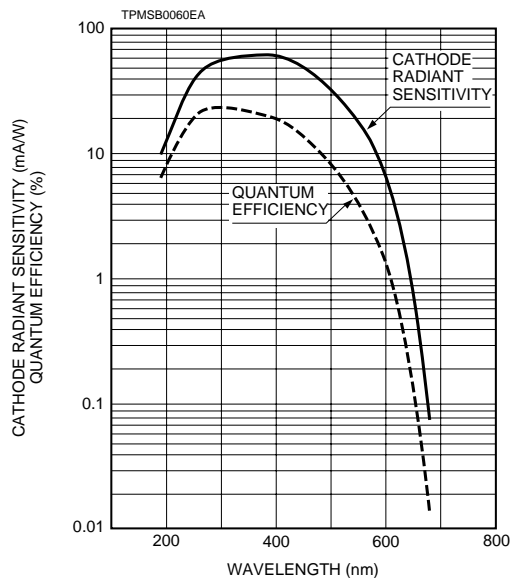
### (1) Current Hysteresis

The tube is operated at 750 volts with an anode current of 1 micro-ampere for 5 minutes. The light is then removed from the tube for a minute. The tube is then re-illuminated by the previous light level for a minute to measure the variation.

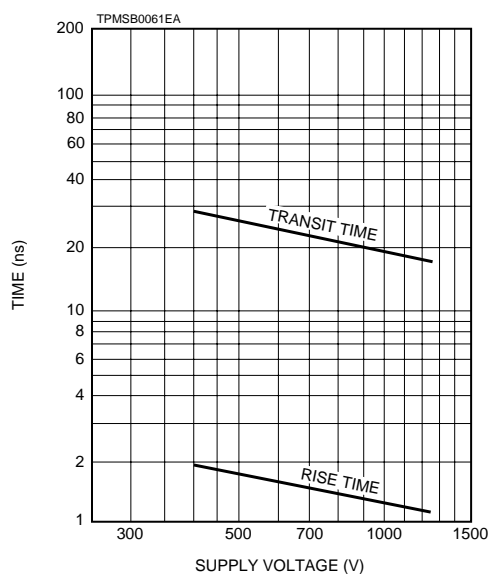
### (2) Voltage Hysteresis

The tube is operated at 300 volts with an anode current of 0.1 micro-ampere for 5 minutes. The light is then removed from the tube and the supply voltage is quickly increased to 800 volts. After a minute, the supply voltage is then reduced to the previous value and the tube is re-illuminated for a minute to measure the variation.

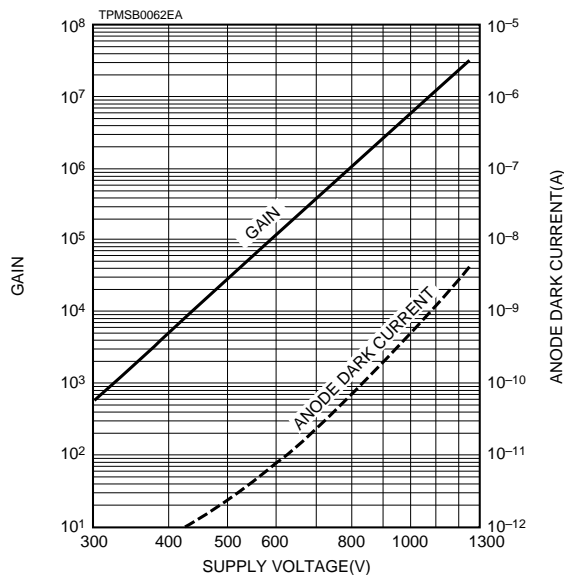
**Figure 3: Typical Spectral Response**



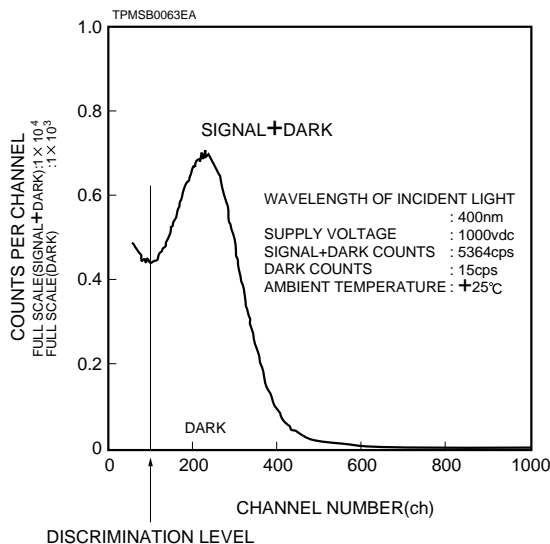
**Figure 4: Typical Time Response**



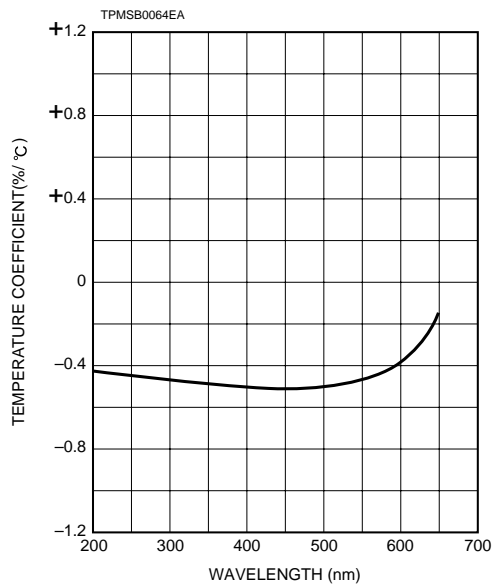
**Figure 5: Typical Gain and Anode Dark Current (R2693)**



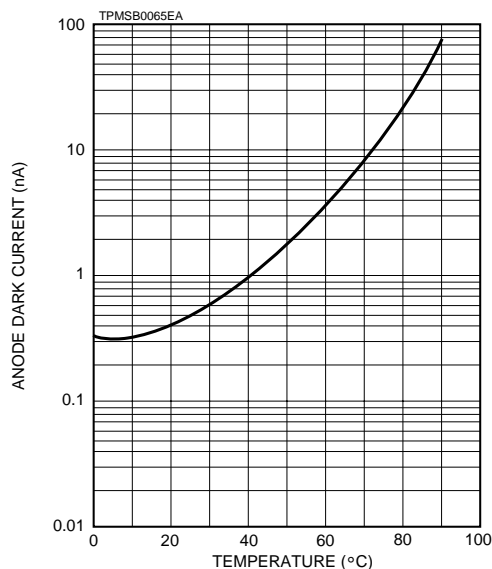
**Figure 6: Typical Single Photoelectron Pulse Height Distribution (R2693P)**



**Figure 7: Typical Temperature Coefficient of Anode Sensitivity**

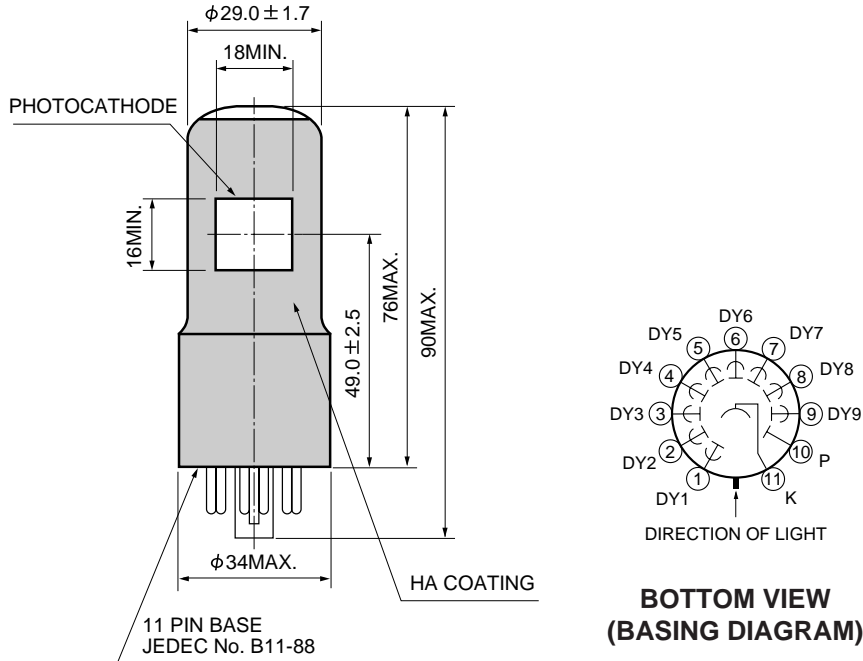


**Figure 8: Typical Temperature Characteristics of Dark Current(R2693) (at 100V, after 30minutes storage)**



# PHOTOMULTIPLIER TUBES R2693, R2693P

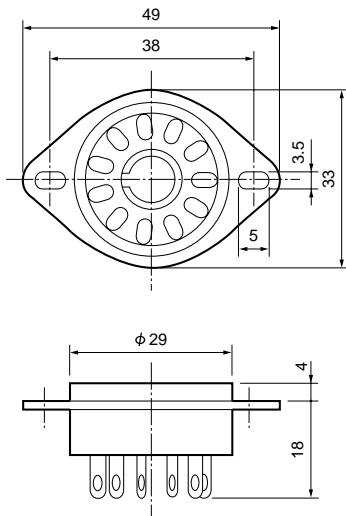
Figure 9: Dimensional Outline and Basing Diagram (Unit: mm)



TPMSA0007EA

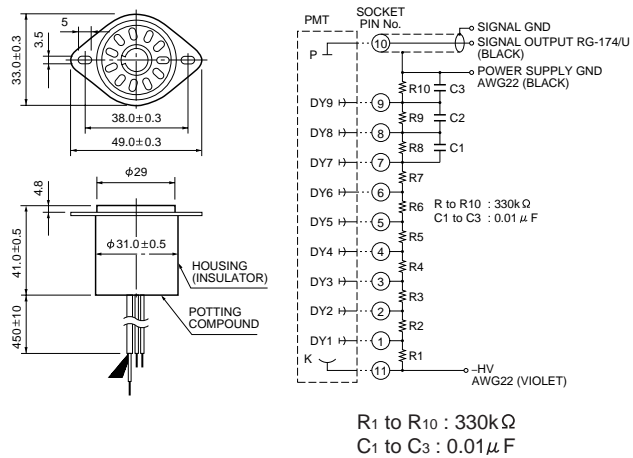
Figure 10: Optional Accessories (Unit: mm)

## Socket E678-11A



TACCA0008EB

## D Type Socket Assembly E717-21



TACCA0002ED

※Hamamatsu also provides C4900 series compact high voltage power supplies and C6270 series DP type socket assemblies which incorporate a DC to DC converter type high voltage power supply.

**Warning—Personal Safety Hazards**  
Electrical Shock—Operating voltages applied to this device present a shock hazard.

# HAMAMATSU

HAMAMATSU PHOTONICS K.K., Electoron Tube Center

314-5, Shimokanzo, Toyooka-village, Iwata-gun, Shizuoka-ken, 438-0193, Japan, Telephone: (81)539/62-5248, Fax: (81)539/62-2205

U.S.A.: Hamamatsu Corporation: 360 Foothill Road, Bridgewater, N.J. 08807-0910, U.S.A., Telephone: (1)908-231-0960, Fax: (1)908-231-1218

Germany: Hamamatsu Photonics Deutschland GmbH: Arzbergerstr. 10, D-82211 Herrsching am Ammersee, Germany, Telephone: (49)8152-375-0, Fax: (49)8152-2658

France: Hamamatsu Photonics France S.A.R.L.: 8, Rue du Saule Trapu, Parc du Moulin de Massy, 91882 Massy Cedex, France, Telephone: (33)1 69 53 71 00, Fax: (33)1 69 53 71 10

United Kingdom: Hamamatsu Photonics UK Limited: Lough Point, 2 Gladbeck Way, Windmill Hill, Enfield, Middlesex EN2 7JA, United Kingdom, Telephone: (44)181-367-3560, Fax: (44)181-367-6384

North Europe: Hamamatsu Photonics Norden AB: Färögatan 7, S-164-40 Kista Sweden, Telephone: (46)8-703-29-50, Fax: (46)8-750-58-95

Italy: Hamamatsu Photonics Italia: S.R.L.: Via Della Moia, 1/E, 20020 Arese, (Milano), Italy, Telephone: (39)2-935 81 733, Fax: (39)2-935 81 741

TPMS1014E01  
MAR. 1993