



### Description

The ICS502 LOCO™ is the most cost effective way to generate a high-quality, high-frequency clock output and a reference from a lower frequency crystal or clock input. The name LOCO stands for Low Cost Oscillator, as it is designed to replace crystal oscillators in most electronic systems. Using Phase-Locked Loop (PLL) techniques, the device uses a standard fundamental mode, inexpensive crystal to produce output clocks up to 160 MHz.

Stored in the chip's ROM is the ability to generate six different multiplication factors, allowing one chip to output many common frequencies (see table on page 2).

This product is intended for clock generation. It has low output jitter (variation in the output period), but input to output skew and jitter are not defined or guaranteed. For applications which require defined input to output skew, use the ICS570B.

### Features

- Packaged as 8-pin SOIC or die
- Available in Pb (lead) free package
- ICS' lowest cost PLL clock
- Zero ppm multiplication error
- Easy to cascade with ICS5xx series
- Input crystal frequency of 5 – 27 MHz
- Input clock frequency of 2 – 50 MHz
- Output clock frequencies up to 190 MHz
- Low jitter – 50 ps one sigma
- Compatible with all popular CPUs
- Duty cycle of 45/55 up to 160 MHz
- Operating voltages of 3.0 to 5.5 V
- 25 mA drive capability at TTL levels
- Industrial temperature version available
- Advanced, low-power CMOS process

### Block Diagram

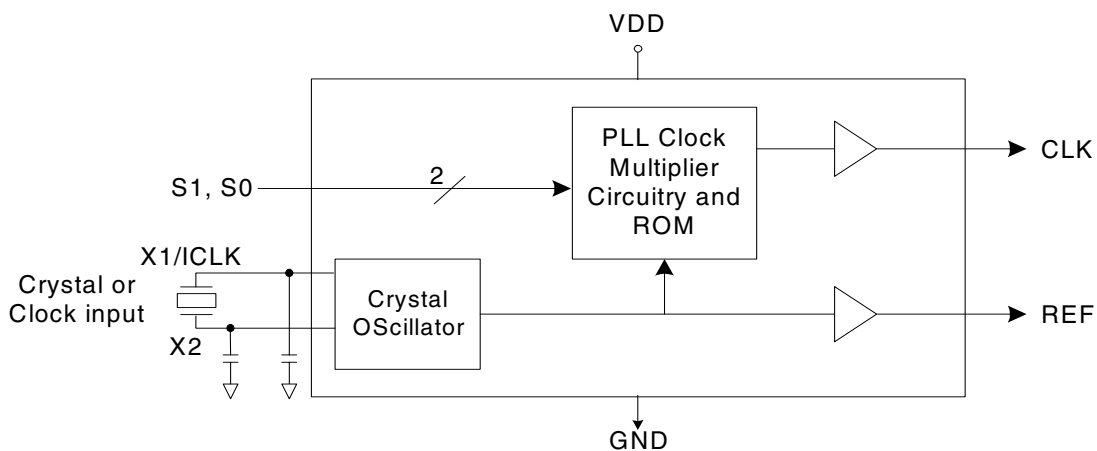



## Pin Assignment

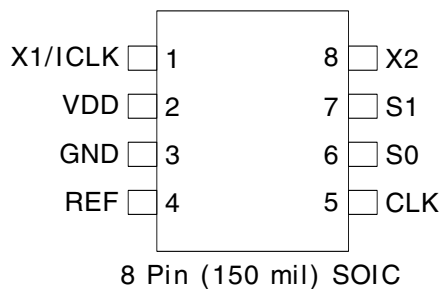

## Clock Decoding Table (MHz)

S1	S0	CLK
0	0	x2
0	1	x5
M	0	x3
M	1	x3.33
1	0	x4
1	1	x2.5

Minimum input frequency for all selections is per table on page 3.

0 = connect directly to ground

1 = connect directly to VDD

M = leave unconnected (floating)

## Common Output Frequency Examples (MHz)

<b>Output</b>	<b>20</b>	<b>25</b>	<b>30</b>	<b>32</b>	<b>33.33</b>	<b>37.5</b>	<b>40</b>	<b>48</b>	<b>50</b>	<b>54</b>	<b>60</b>
<b>Input</b>	10	10	10	16	10	15	20	16	20	13.5	20
<b>Selection (S1, S0)</b>	0, 0	1, 1	M, 0	0, 0	M, 1	1, 1	0, 0	M, 0	1, 1	1, 0	M, 0
<b>Output</b>	<b>64</b>	<b>66.66</b>	<b>72</b>	<b>75</b>	<b>80</b>	<b>81</b>	<b>90</b>	<b>100</b>	<b>108</b>	<b>120</b>	<b>135</b>
<b>Input</b>	16	20	24	15	20	27	27	20	27	24	27
<b>Selection (S1, S0)</b>	1, 0	M, 1	M, 0	0, 1	1, 0	M, 0	M, 1	0, 1	1, 0	0, 1	0, 1

## Pin Descriptions

Pin Number	Pin Name	Pin Type	Pin Description
1	XI/ICLK	Input	Crystal connection or clock input.
2	VDD	Power	Connect to +3.3 V or +5 V.
3	GND	Power	Connect to ground.
4	REF	Output	Buffered crystal oscillator output clock.
5	CLK	Output	Clock output per table above.
6	S0	Input	Select 0 for output clock. Connect to GND or VDD.
7	S1	Input	Select 1 for output clock. Connect to GND or VDD or float.
8	X2	Input	Crystal connection. Leave unconnected for clock input.



## External Components

### Decoupling Capacitor

As with any high-performance mixed-signal IC, the ICS502 must be isolated from system power supply noise to perform optimally.

A decoupling capacitor of 0.01 $\mu$ F must be connected between VDD and GND. It must be connected close to the ICS502 to minimize lead inductance. No external power supply filtering is required for the ICS502.

### Series Termination Resistor

A 33 $\Omega$  terminating resistor can be used next to the CLK pin. The total on-chip capacitance is approximately 12 pF. A parallel resonant, fundamental mode crystal should be used.

## Crystal Load Capacitors

The device crystal connections should include pads for small capacitors from X1 to ground and from X2 to ground. These capacitors are used to adjust the stray capacitance of the board to match the nominally required crystal load capacitance. Because load capacitance can only be increased in this trimming process, it is important to keep stray capacitance to a minimum by using very short PCB traces (and no vias) between the crystal and device. Crystal capacitors, if needed, must be connected from each of the pins X1 and X2 to ground.

The value (in pF) of these crystal caps should equal  $(C_L - 12 \text{ pF}) \times 2$ . In this equation,  $C_L$  = crystal load capacitance in pF. Example: For a crystal with a 16 pF load capacitance, each crystal capacitor would be 8 pF  $[(16 - 12) \times 2] = 8$ .

## Absolute Maximum Ratings

Stresses above the ratings listed below can cause permanent damage to the ICS502. These ratings, which are standard values for ICS commercially rated parts, are stress ratings only. Functional operation of the device at these or any other conditions above those indicated in the operational sections of the specifications is not implied. Exposure to absolute maximum rating conditions for extended periods can affect product reliability. Electrical parameters are guaranteed only over the recommended operating temperature range.

Item	Rating
Supply Voltage, VDD	7 V
All Inputs and Outputs	-0.5 V to VDD+0.5 V
Ambient Operating Temperature	-40 to +85°C
Storage Temperature	-65 to +150°C
Soldering Temperature	260°C

## Recommended Operation Conditions

Parameter	Min.	Typ.	Max.	Units
Ambient Operating Temperature	0	–	+70	°C
Power Supply Voltage (measured in respect to GND)	+3		+5.5	V



## DC Electrical Characteristics

VDD=5.0 V ±5% , Ambient temperature 0 to +70°C, unless stated otherwise

Parameter	Symbol	Conditions	Min.	Typ.	Max.	Units
Operating Voltage	VDD		3		5.5	V
Input High Voltage, ICLK only	V <sub>IH</sub>	ICLK (pin 1)	(VDD/2)+1			V
Input Low Voltage, ICLK only	V <sub>IL</sub>	ICLK (pin 1)			(VDD/2)-1	V
Input High Voltage	V <sub>IH</sub>	OE (pin 7)	2			V
Input Low Voltage	V <sub>IL</sub>	OE (pin 7)			0.8	V
Input High Voltage	V <sub>IH</sub>	S0, S1	VDD-0.5			V
Input Mid Voltage	V <sub>IM</sub>	S1		VDD/2		V
Input Low Voltage	V <sub>IL</sub>	S0, S1			0.5	V
Output High Voltage	V <sub>OH</sub>	I <sub>OH</sub> = -25 mA	2.4			V
Output Low Voltage	V <sub>OL</sub>	I <sub>OL</sub> = 25 mA			0.4	V
IDD Operating Supply Current, 20 MHz crystal		No load, 100 MHz		20		mA
Short Circuit Current		CLK output		±70		mA
On-Chip Pull-up Resistor		Pin 7		270		kΩ
Input Capacitance, S1, S0, and OE		Pins 4, 6, 7		4		pF



## AC Electrical Characteristics

VDD = 5.0 V ±5%, Ambient Temperature 0 to +70° C, unless stated otherwise

Parameter	Symbol	Conditions	Min.	Typ.	Max.	Units
Input Frequency, crystal input	F <sub>IN</sub>		5		27	MHz
Input Frequency, clock input	F <sub>IN</sub>		2		50	MHz
Output Frequency, VDD = 4.5 to 5.5V	F <sub>OUT</sub>	-40 to +70°C	14		160	MHz
Output Frequency, VDD = 3.0 to 3.6V		-40 to +85°C	14		120	MHz
Output Frequency, VDD = 4.5 to 5.5V	F <sub>OUT</sub>	+25°C	14		190	MHz
Output Frequency, VDD = 3.0 to 3.6V		+25°C	14		140	MHz
Output Clock Rise Time	t <sub>OR</sub>	0.8 to 2.0 V		1		ns
Output Clock Fall Time	t <sub>OF</sub>	2.0 to 8.0V		1		ns
Output Clock Duty Cycle	t <sub>OD</sub>	1.5V, up to 160 MHz	45	49-51	55	%
PLL Bandwidth			10			kHz
Output Enable Time, OE high to output on				50		ns
Output Disable Time, OE low to tri-state				50		ns
Absolute Clock Period Jitter	t <sub>ja</sub>	Deviation from mean		±70		ps
One Sigma Clock Period Jitter	t <sub>js</sub>			25		ps



## Package Outline and Package Dimensions (8-pin SOIC, 150 Mil. Narrow Body)

Package dimensions are kept current with JEDEC Publication No. 95

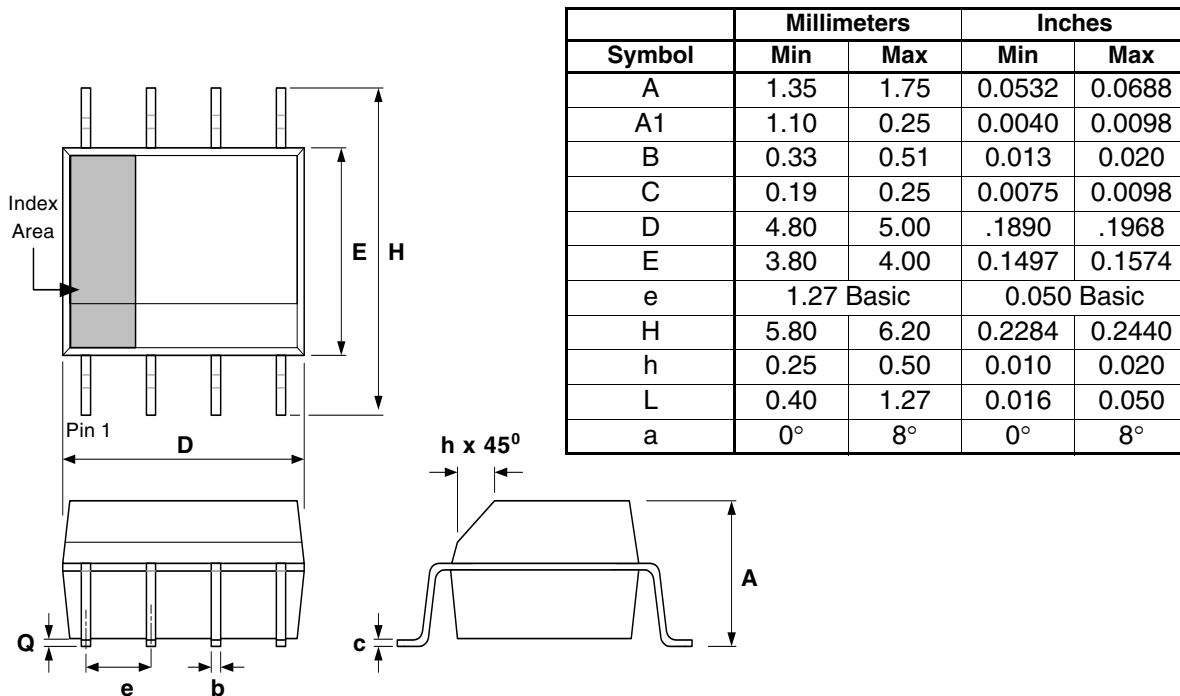

## Ordering Information

Part / Order Number	Marking	Shipping Packaging	Package	Temperature
ICS502M	ICS502M	Tubes	8-pin SOIC	0 to +70° C
ICS502MT	ICS502M	Tape and Reel	8-pin SOIC	0 to +70° C
ICS502MI	ICS502I	Tubes	8-pin SOIC	-40 to +85° C
ICS502MIT	ICS502I	Tape and Reel	8-pin SOIC	-40 to +85° C
ICS502MLF	502MLF	Tubes	8-pin SOIC	0 to +70° C
ICS502MLFT	502MLF	Tape and Reel	8-pin SOIC	0 to +70° C
ICS502MILF	502ILF	Tubes	8-pin SOIC	-40 to +85° C
ICS502MILFT	502ILF	Tape and Reel	8-pin SOIC	-40 to +85° C
ICS502-DWF	-	Die on uncut, probed wafers		0 to +70° C
ICS502-DPK	-	Tested die in waffle pack		0 to +70° C

**Parts that are ordered with an “LF” suffix to the part number are the Pb-free configuration and are RoHS compliant.**

While the information presented herein has been checked for both accuracy and reliability, Integrated Circuit Systems (ICS) assumes no responsibility for either its use or for the infringement of any patents or other rights of third parties, which would result from its use. No other circuits, patents, or licenses are implied. This product is intended for use in normal commercial applications. Any other applications such as those requiring extended temperature range, high reliability, or other extraordinary environmental requirements are not recommended without additional processing by ICS. ICS reserves the right to change any circuitry or specifications without notice. ICS does not authorize or warrant any ICS product for use in life support devices or critical medical instruments.