

GaAs SPDT Switch

DC - 4 GHz

MASW4030G

V 2.00

Features

- Absorbive or Reflective
- Excellent Intermodulation Products
- Excellent Temperature Stability
- Fast Switching Speed, 3 ns Typical
- Ultra Low DC Power Consumption
- Independent Bias Control

Guaranteed Specifications*

-55°C to +85°C

Frequency Range	DC – 4.0 GHz	
Insertion Loss	DC – 1.0 GHz	0.6 dB Max
	DC – 2.0 GHz	0.8 dB Max
	DC – 4.0 GHz	1.0 dB Max
Isolation	DC – 1.0 GHz	60 dB Min
	Absorbive Mode DC – 2.0 GHz	50 dB Min
	Reflective Mode DC – 2.0 GHz	42 dB Min
	DC – 4.0 GHz	40 dB Min
VSWR	DC – 1.0 GHz	1.2:1 Max
	DC – 2.0 GHz	1.2:1 Max
	DC – 4.0 GHz	1.5:1 Max

Operating Characteristics

Impedance 50 Nominal

Switching Characteristics

tRISE, tFALL (10/90% or 90/10% RF) 3 ns Typ
 tON, tOFF (50% CTL to 90/10% RF) 6 ns Typ
 Transients (In-Band) 20 mV Typ

Input Power for 1dB Compression**

Control Voltages (Vdc)	0/-5	0/-8
0.05 GHz	24 dBm	25 dBm Typ
0.5 – 4.0 GHz	30 dBm	33 dBm Typ

Intermodulation Intercept Point (for two-tone input power up to +5 dBm)

Intercept Points	IP ₂	IP ₃
0.5 GHz	62	39 dBm Typ
0.5 – 4.0 GHz	68	46 dBm Typ

Control Voltages (Complementary Logic)

VINLow 0 to -0.2 V @ 9 μA Max
 VINHi -5 V @ 25 μA Typ to -8 V @ 0.75 μA Max

Die Size 0.043" x 0.041" x 0.010"
 (1.08mm x 1.03mm x 0.25mm)

* Previously MA4GM202MTC

** All specifications apply with 50 impedance connected to all RF ports, and -5 Vdc control voltages.

*** Loss changes 0.0025 dB/°C

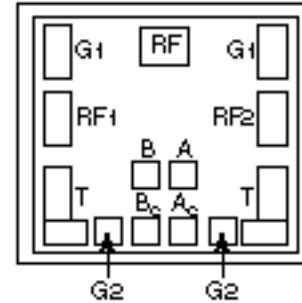

Typical Performance @ +25°C***

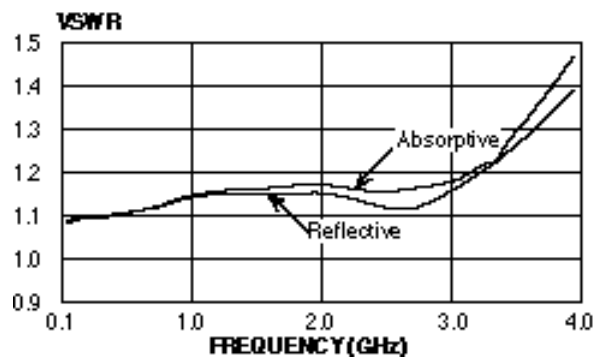
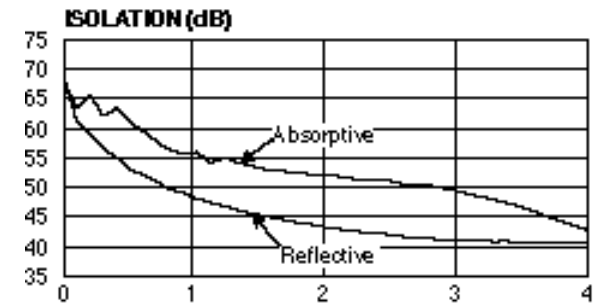
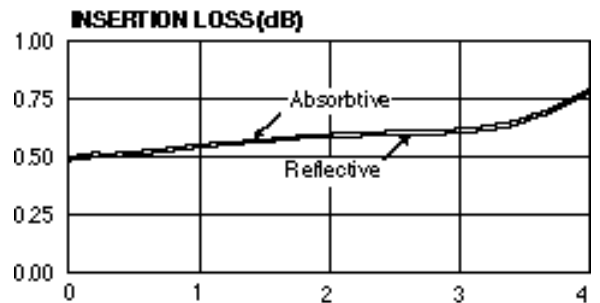

Handling Precautions

Permanent damage to the MASW4030G may occur if the following precautions are not adhered to:

- A. Cleanliness — The MASW4030G should be handled in a clean environment. DO NOT attempt to clean unit after the MASW4030G is installed.
- B. Static Sensitivity — All chip handling equipment and personnel should be DC grounded.
- C. Transient — Avoid instrument and power supply transients while bias is applied to the MASW4030G. Use shielded signal and bias cables to minimize inductive pick-up.
- D. Bias — Apply voltage to either of the complementary control ports only when the other is grounded. No port should be allowed to “float”.
- E. General Handling — It is recommended that the MASW4030G chip be handled along the long side of the die with a sharp pair of bent tweezers. DO NOT touch the surface of the chip with fingers or tweezers.

Mounting

The MASW4030G is back-metallized with Pd/Ni/Au(100/1,000/10,000Å) metallization. It can be die-mounted with AuSn eutectic preforms or with thermally conductive epoxy. The package surface should be clean and flat before attachment.

Eutectic Die Attach:

- A. A 80/20 gold/tin preform is recommended with a work surface temperature of approximately 255°C and a tool temperature of 265°C. When hot 90/10 nitrogen/hydrogen gas is applied, tool tip temperature should be approximately 290°C.
- B. DO NOT expose the MASW4030G to a temperature greater than 320°C for more than 20 seconds. No more than 3 seconds of scrubbing should be required for attachment.

Epoxy Die Attach:

- A. Apply a minimum amount of epoxy and place the MASW4030G into position. A thin epoxy fillet should be visible around the perimeter of the chip.
- B. Cure epoxy per manufacturer’s recommended schedule.
- C. Electrically conductive epoxy may be used but is not required.

Truth Table

Condition of Switch	Control Inputs					Condition of BondPad	
	A	B	T	G1	G2	RF1	RF2
Absorbitive	V _{IN} Low	V _{IN} Hi	GND	GND	—	On	Off
SPDT	V _{IN} Hi	V _{IN} Low	GND	GND	—	Off	On
Reflective	V _{IN} Low	V _{IN} Hi	—	GND	GND	On	Off

Schematic

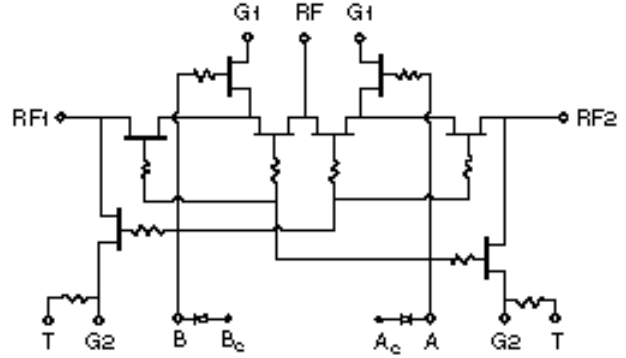

Wire Bonding

- A. Ball or wedge with 1.0 mil diameter pure gold wire. Thermosonic wirebonding with a nominal stage temperature of 150°C and a ball bonding force of 40 to 50 grams or wedge bonding force of 18 to 22 grams is recommended. Ultrasonic energy and time should be adjusted to the minimum levels achieve reliable wirebonds.
- B. Wirebonds should be started on the chip and terminated on the package. GND bonds should be as short as possible; at least three and no more than four bond wires from ground pads to package are recommended.

Maximum Ratings	
A. Control Value (A or B):	–8.5 Vdc
B. Max Input RF Power:	+34 dBm (500 MHz–4 GHz)
C. Storage Temperature:	–65°C to +175°C
D. Max Operating Temperature:	+175°C

BondPad Dimensions — Inches (mm)	
RF1, RF2	0.005 x 0.008 (0.125 x 0.200)
RFA1, RFB1	0.008 x 0.004 (0.200 x 0.100)
RFA2, RFB2	0.004 x 0.004 (0.100 x 0.100)
A, B, A _C , B _C	0.008 x 0.004 (0.200 x 0.100)