

VICOR CONFIDENTIAL

THIS DOCUMENT AND THE DATA DISCLOSED HEREIN OR HEREWITH IS NOT TO BE REPRODUCED, USED, OR DISCLOSED IN WHOLE OR IN PART TO ANYONE WITHOUT PERMISSION OF VICOR CORP.

REV.	DESCRIPTION	DATE	APPROVED
#5	MODIFY TO LOOK LIKE VENDOR'S DWG	RCM 8/14/98	KGD
#6	ADDED ARTWORK	AK 2/1/99	KGD
#7	ADDED NOTE 5	PEI 7/20/99	JMR

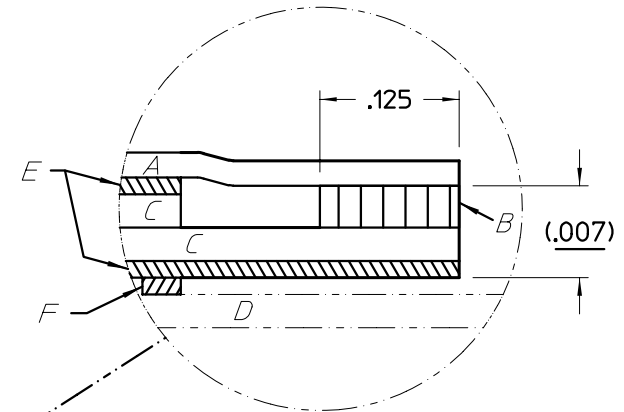
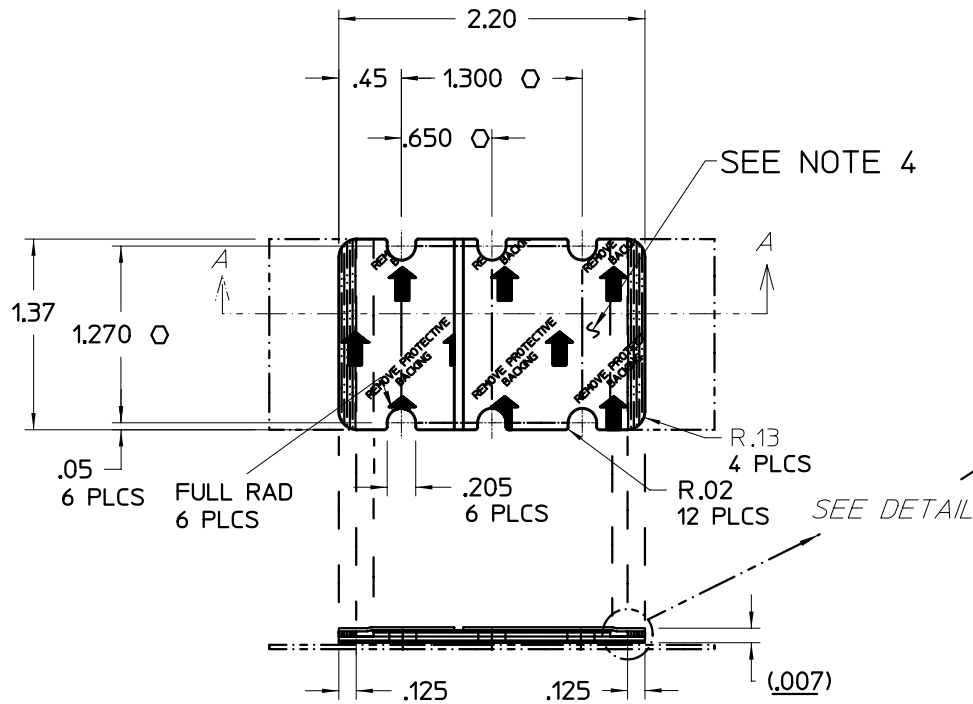

DETAIL :

- A. SPLIT RELEASE LINER.
- B. ADHESIVE STRIP, .0025 THICK .125 WIDE.
- C. ALUMINUM ALLOY 1145-0, .002 THICK.
- D. ROLL CARRIER WITH ADHESIVE STRIP BONDING.
- E. PHASE CHANGE THERMAL COMPOUND.
- F. ADHESIVE STRIPS ON ROLL CARRIER.

SECTION A-A

(VERTICAL THICKNESS IS NOT SHOWN TO SCALE)

NOTES:

- 1. MATERIAL: MAKE FROM POWER DEVICES AL-2-22H-137
- 2. THICKNESS: .007±.001.
- 3. SEE DETAIL FOR ASSY ORDER.
- 4. FOR ARTWORK SHOWN HERE SEE DWG# 20200.
- 5. \varnothing DENOTE CRITICAL CHARACTERISTIC FOR LOT INSPECTION.

DRAWN BY J. RENAUD		DATE 2/13/97			
UNLESS OTHERWISE SPECIFIED DIMENSIONS ARE IN INCHES-TOLERANCES ARE: FRACTIONS DECIMALS ANGLES *1/64 XX* .01 *1° XXX** .005					
THIRD ANGLE PROJECTION 		SIZE B	FSCM NO. 67131	DWG NO. 16192	REV # 7
DO NOT SCALE DRAWING		SCALE FULL	SHEET 1 OF 1		