

# XC6210 Series

## High Current, High Speed LDO Regulators



December 15, 2004 VS

### Preliminary

- ◆ Low Power Consumption : 35 $\mu$ A (TYP.)
- ◆ Maximum Output Current : More than 700mA (800mA limit)
- ◆ Dropout Voltage : 50mV @ 100mA  
: 100mV @ 200mA
- ◆ Operating Voltage Range : 1.5V ~ 6.0V
- ◆ Output Voltage Range : 0.8V ~ 5.0V
- ◆ Low ESR Capacitor Compatible

### ■ GENERAL DESCRIPTION

The XC6210 series are precise, low noise, high current, positive voltage low dropout regulators. They are fabricated using Torex's CMOS process.

The series features a voltage reference, an error amplifier, a current limiter, and a phase compensation circuit plus a driver transistor.

With a low ON resistance driver transistor built-in, batteries can be used until input-output voltage differential is minimal and can accordingly be used for a longer time.

The series is also compatible with low ESR ceramic capacitors which give added output stability.

The output voltage of the LDO and detect voltage of the detector is selectable in 100mV increments within the range of 0.8V to 5.0V.

The current limiter's foldback circuit also operates as the output current limiter and the output pin protection.

The IC's internal regulator circuit can be placed in stand-by mode via the CE function. In the stand-by mode, power consumption is greatly reduced.

### ■ APPLICATIONS

- CD-ROMs, CD-R / RW drive
- DVD drive
- HDD drive
- Cameras, Video recorders
- Portable AV equipment
- Battery powered equipment

### ■ FEATURES

- Maximum Output Current : More than 700mA (800mA limit) (1.6V $\leq$ VOUT(T) $\leq$ 5.0V)
- Dropout Voltage : 50mV@IOUT=100mA
- Operating Voltage Range : 1.5V ~ 6.0V
- Output Voltage Range : 0.8V ~ 5.0V (100mV increments)
- Highly Accurate :  $\pm$ 2%
- Low Power Consumption : 35 $\mu$ A (TYP.)
- High Ripple Rejection : 60dB (@1kHz)
- Operational Ambient Temperature : -40 $^{\circ}$ C ~ 85 $^{\circ}$ C
- Ultra Small Packages : SOT-25 (SOT-23-5)  
SOT-89-5  
USP-6B

### ■ TYPICAL APPLICATION CIRCUIT

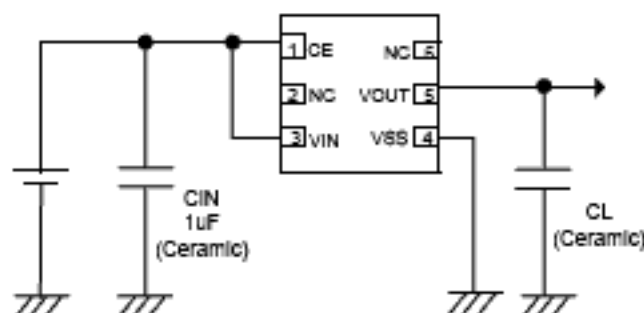

### ■ TYPICAL PERFORMANCE CHARACTERISTICS

- Dropout Voltage vs. Output Current

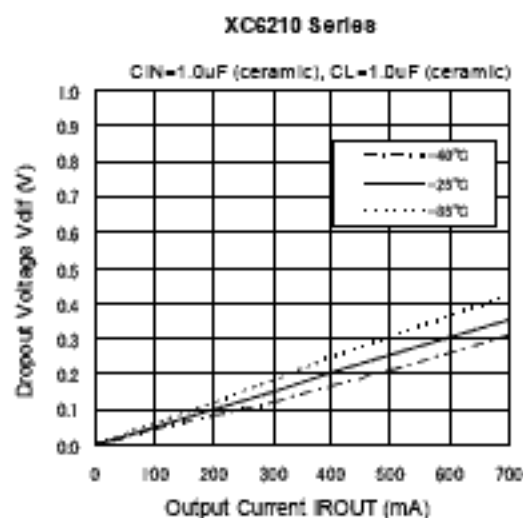

# XC6210 Series

## ■ PIN CONFIGURATION

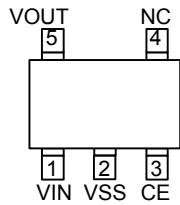

SOT-25 (TOP VIEW)

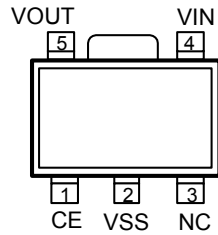

SOT-89-5 (TOP VIEW)

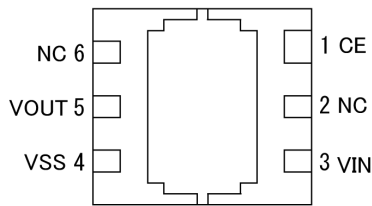

USP-6B (BOTTOM VIEW)

\*Please use the circuit without connecting the heat dissipation pad. If the pad needs to be connected to other pins, it should be connected to the VSS pin.

## ■ PIN ASSIGNMENT

PIN NUMBER			PIN NAME	FUNCTION
SOT-25	SOT-89-5	USP-6B		
3	1	1	CE	ON/OFF Control
1	4	3	VIN	Power Input
2	2	4	VSS	Ground
5	5	5	VOUT	Output
4	3	2, 6	NC	No Connection

## ■ PRODUCT CLASSIFICATION

### ● Selection Guide

CE Input Logic, Internal Pull-Up / Down Resistor

SERIES	CE INPUT LOGIC
XC6210A	High Active with Pull-Down Resistor
XC6210B	High Active with No Pull-Down Resistor
XC6210C	Low Active with Pull-Up Resistor
XC6210D	Low Active with No Pull-Up Resistor

### ● Ordering Information

XC6210 ①②③④⑤⑥

DESIGNATOR	DESCRIPTION	SYMBOL	DESCRIPTION
①	CE Pin Functions	A	: High Active with pull-down resistor
		B	: High Active with no pull-down resistor
		C	: Low Active with pull-up resistor
		D	: Low Active with no pull-up resistor
② ③	Output Voltage	08~50	: ex.) 3.0V → ②=3, ③=0
④	Output Voltage Accuracy	2	: ±2% (VOUT ≤ 1.5V ⇔ ±30mV)
⑤	Packaging Types	M	: SOT-25 (SOT-23-5)
		P	: SOT-89-5
		D	: USP-6B
⑥	Device Orientation	R	: Embossed tape, standard feed
		L	: Embossed tape, reverse feed

**PACKAGING INFORMATION**

● SOT-25 (SOT-23-5)

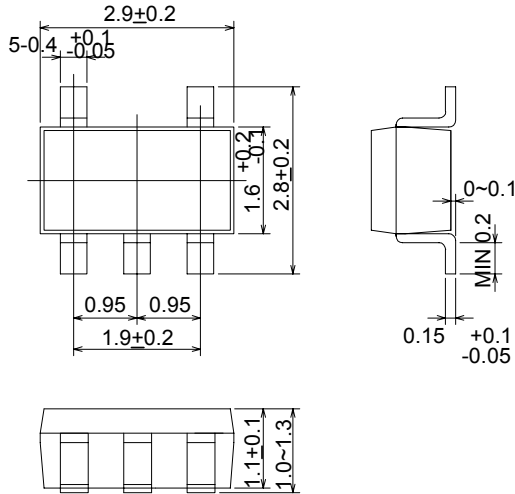

● SOT-89-5

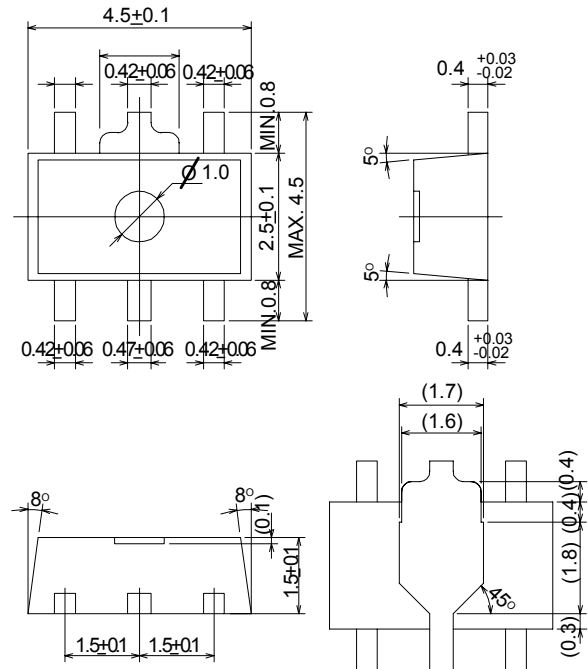

● USP-6B

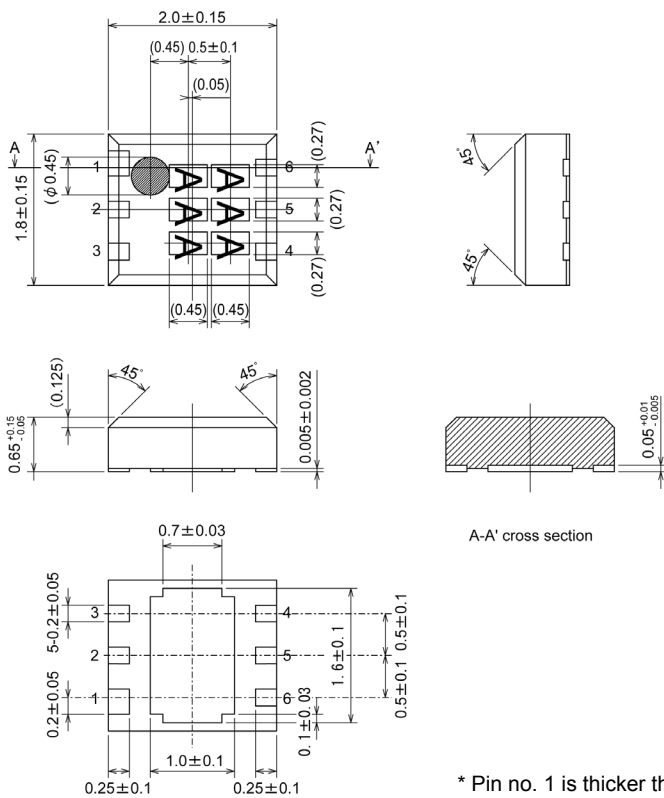

# XC6210 Series

## MARKING RULE

### SOT-25

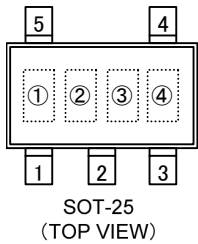

① Represents product series

MARK	PRODUCT SERIES
0	XC6210xxxxxx

② Represents CE function

MARK		PRODUCT SERIES
VOLTAGE=0.1~3.0V	VOLTAGE=3.1~6.0V	
V	A	XC6210Axxxxx
X	B	XC6210Bxxxxx
Y	C	XC6210Cxxxxx
Z	D	XC6210Dxxxxx

### SOT-89-5

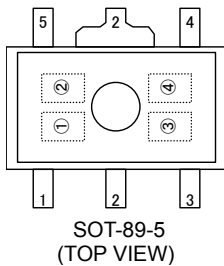

③ Represents output voltage

MARK	OUTPUT VOLTAGE(V)		MARK	OUTPUT VOLTAGE(V)	
0	-	3.1	F	1.6	4.6
1	-	3.2	H	1.7	4.7
2	-	3.3	K	1.8	4.8
3	-	3.4	L	1.9	4.9
4	-	3.5	M	2.0	5.0
5	-	3.6	N	2.1	-
6	-	3.7	P	2.2	-
7	0.8	3.8	R	2.3	-
8	0.9	3.9	S	2.4	-
9	1.0	4.0	T	2.5	-
A	1.1	4.1	U	2.6	-
B	1.2	4.2	V	2.7	-
C	1.3	4.3	X	2.8	-
D	1.4	4.4	Y	2.9	-
E	1.5	4.5	Z	3.0	-

④ Represents production lot number

0 to 9, A to Z reverse character 0 to 9, A to Z repeated (G, I, J, O, Q, W excepted)

### USP-6B

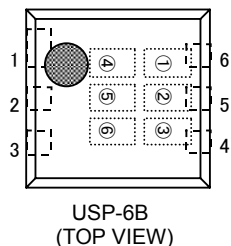

①② Represents product series

MARK		PRODUCT SERIES
①	②	
1	0	XC6210xxxxxx

③ Represents CE Function

MARK	TYPE	PRODUCT SERIES
A	High Active With Pull-Down Resistor	XC6210AxxxDx
B	High Active With No Pull-Down Resistor	XC6210AxxxDx
C	Low Active With Pull-Up Resistor	XC6210AxxxDx
D	Low Active With No Pull-Up Resistor	XC6210AxxxDx
S	Custom	XC6210AxxxDx

④⑤ Represents output voltage

MARK		VOLTAGE (V)	PRODUCT SERIES
④	⑤		
3	3	3.3	XC6210x33xDx
5	0	5.0	XC6210x53xDx

⑥ Represents production lot number

0 to 9, A to Z repeated (G, I, J, O, Q, W, excepted)

Note: No character inversion used.

■ **BLOCK DIAGRAM**

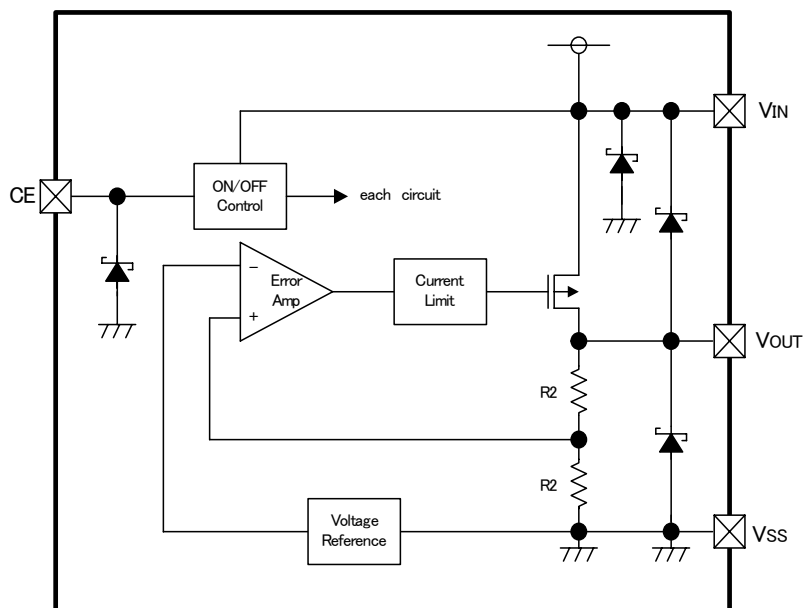

■ **ABSOLUTE MAXIMUM RATINGS**

Ta=25°C

PARAMETER	SYMBOL	RATINGS	UNITS
Input Voltage	V <sub>IN</sub>	6.5	V
Output Current *	I <sub>OUT</sub>	900	mA
Output Voltage	V <sub>OUT</sub>	V <sub>SS</sub> -0.3 ~ V <sub>IN</sub> +0.3	V
CE Pin Voltage	V <sub>CE</sub>	V <sub>SS</sub> -0.3 ~ 6.5	V
Power Dissipation	SOT-25	P <sub>d</sub>	mW
	SOT-89-5		
	USP-6B		
Operating Temperature Range	T <sub>opr</sub>	- 40 ~ + 85	°C
Storage Temperature Range	T <sub>stg</sub>	- 55 ~ + 125	°C

\* I<sub>OUT</sub>=P<sub>d</sub> / (V<sub>IN</sub> - V<sub>OUT</sub>)

# XC6210 Series

## ■ ELECTRICAL CHARACTERISTICS

●XC6210 series

Ta=25 °C

PARAMETER	SYMBOL	CONDITIONS	MIN.	TYP.	MAX.	UNITS	CIRCUIT
Output Voltage (*2), (*3)	VOUT(E)	VIN=VOUT(T)+1.0V, IOUT=30mA VCE=ON(VIN or VSS)	x 0.98	VOUT(T)	x 1.02	V	①
		VOUT(T)≤1.5V, IOUT=30mA VCE=ON(VIN or VSS)	(-30mV)	VOUT(T)	(+30mV)		
Maximum Output Current [VOUT(E)>1.6V]	IOUTMAX	VIN=VOUT(T)+1.0V, VCE=ON(VIN or VSS)	700	-	-	mA	①
Maximum Output Current [VOUT(E)≤1.5V]	IOUTMAX	VIN=VOUT(T)+1.0V, VCE=ON(VIN or VSS)	500	-	-	mA	①
Load Regulation	ΔVOUT	1mA≤IOUT≤100mA, VCE=ON(VIN or VSS)	-	15	60	mV	①
Dropout Voltage (*4)	Vdif1	IOUT=30mA, VCE=ON(VIN or VSS)	E-1			mV	①
	Vdif2	IOUT=100mA, VCE=ON(VIN or VSS)	E-2			mV	①
Stand-by Current	ISTB	VIN=VOUT(T)+1.0V, VCE=OFF (VIN or VSS)	-	0.01	0.10	μA	②
Supply Current (A type)	IDD	VIN=VCE=VOUT(T)+1.0V	E-3			μA	②
Supply Current (B type)		VIN=VCE=VOUT(T)+1.0V	-	35	-	μA	②
Supply Current (C type)		VIN=VOUT(T)+1.0V, VCE=VSS	E-3			μA	②
Supply Current (D type)		VIN=VOUT(T)+1.0V, VCE=VSS	-	35	-	μA	②
Line Regulation	$\frac{\Delta V_{OUT}}{\Delta V_{IN} \cdot V_{OUT}}$	VOUT(T)+1.0V≤VIN≤6.0V VCE=ON(VIN or VSS), IOUT=30mA	-	0.01	0.20	% / V	①
Input Voltage	VIN		1.5	-	6.0	V	-
Output Voltage Temperature Characteristics	$\frac{\Delta V_{OUT}}{\Delta T_{opr} \cdot V_{OUT}}$	IOUT=30mA, VCE=ON(VIN or VSS) -40 °C≤Topr≤85 °C	-	± 100	-	ppm/ °C	①
Ripple Rejection Rate	PSRR	VIN=[VOUT(T)+1.0]VDC+0.5Vp-pAC When VOUT(T)≥4.75V → VIN=5.75VDC+0.5Vp-pAC VCE=ON(VIN or VSS), IOUT=30mA, f=1kHz	-	60	-	dB	③
Current Limiter [VOUT(E)>1.6V]	Ilim	VIN=VOUT(T)+1.0V, VCE=ON(VIN or VSS)	700	800	-	mA	①
Current Limiter [VOUT(E)≤1.5V]	Ilim	VIN=VOUT(T)+1.0V, VCE=ON(VIN or VSS)	-	800	-	mA	①
Short-Circuit Current	Ishort	VIN=VOUT(T)+1.0V, VCE=ON(VIN or VSS)	-	50	-	mA	①
CE "High" Level Voltage	VCEH		1.3	-	6.0	V	①
CE "Low" Level Voltage	VCEL		-	-	0.25	V	①
CE "High" Level Current (A type)	ICEH	VCE=VIN=VOUT(T)+1.0V	- 0.10	-	E-4	μA	①
CE "High" Level Current (B type)			- 0.10	-	0.10	μA	①
CE "Low" Level Current (C type)	ICEL	VIN=VOUT(T)+1.0V, VCE=VSS	E-5	-	0.10	μA	①
CE "Low" Level Current (D type)			- 0.10	-	0.10	μA	①

### NOTE:

\*1: Unless otherwise stated, VIN=VOUT(T)+1.0V

\*2: VOUT(T)=Specified output voltage

\*3: VOUT(E)=Effective output voltage

(i.e. the output voltage when "VOUT(T)+1.0V" is provided while maintaining a certain IOUT value).

\*4: Vdif={VIN1<sup>(\*)6</sup>-VOUT1<sup>(\*)5</sup>}

\*5: A voltage equal to 98% of the output voltage whenever a stabilized VOUT1=IOUT{VOUT(T)+1.0V} is input.

\*6: VIN1=The input voltage when VOUT1, which appears as input voltage is gradually decreased.

\*7: VOUT(T)≤1.50V MIN.: VOUT(T) - 30mV, MAX.: VOUT(T) +30mV

\*8: CE conditions: XC6210A / B type: ON=VIN, OFF=VSS

XC6210C / D type: ON=VSS, OFF=VIN

■ ELECTRICAL CHARACTERISTICS (Continued)

● Dropout Voltage, Supply Current, CE 'H/L' Level Current Chart

SETTING OUTPUT VOLTAGE	OUTPUT VOLTAGE		E-1		E-2		E-3		E-4	E-5
			DROPOUT VOLTAGE 1		DROPOUT VOLTAGE 2		SUPPLY CURRENT		CE <sup>H</sup> LEVEL CURRENT	CE <sup>L</sup> LEVEL CURRENT
(V)	(V)		(mV)		(mV)		(μA)		(μA)	(μA)
V <sub>OUT(T)</sub>	V <sub>OUT</sub>		V <sub>dif1</sub>		V <sub>dif2</sub>		I <sub>DD</sub>		I <sub>CEH</sub>	I <sub>CEL</sub>
	MIN.	MAX.	TYP.	MAX.	TYP.	MAX.	TYP.	MAX.	TYP.	MAX.
0.80	0.770	0.830	100	700	250	800	36.0	-	5.0	-5.0
0.85	0.820	0.880		600		700				
0.90	0.870	0.930								
0.95	0.920	0.980								
1.00	0.970	1.030	50	500	150	600	37.5	-	6.5	-6.5
1.05	1.020	1.080		400		500				
1.10	1.070	1.130								
1.15	1.120	1.180								
1.20	1.170	1.230	30	300	100	400	37.5	-	6.5	-6.5
1.25	1.220	1.280		200		300				
1.30	1.270	1.330		100		250				
1.35	1.320	1.380								
1.40	1.370	1.430								
1.45	1.420	1.480								
1.50	1.470	1.530	27.0	41.0	90.0	135.0	39.0	-	8.0	-8.0
1.55	1.519	1.581								
1.60	1.568	1.632								
1.65	1.617	1.683								
1.70	1.666	1.734								
1.75	1.715	1.785								
1.80	1.764	1.836								
1.85	1.813	1.887								
1.90	1.862	1.938								
1.95	1.911	1.989								
2.00	1.960	2.040	25.0	37.0	80.0	120.0	40.5	-	9.5	-9.5
2.05	2.009	2.091								
2.10	2.058	2.142								
2.15	2.107	2.193								
2.20	2.156	2.244								
2.25	2.205	2.295								
2.30	2.254	2.346								
2.35	2.303	2.397								
2.40	2.352	2.448								
2.45	2.401	2.499								
2.50	2.450	2.550	18.0	28.0	60.0	90.0	42.0	-	11.0	-11.0
2.55	2.499	2.601								
2.60	2.548	2.652								
2.65	2.597	2.703								
2.70	2.646	2.754								
2.75	2.695	2.805								
2.80	2.744	2.856								
2.85	2.793	2.907								
2.90	2.842	2.958								
2.95	2.891	3.009								

# XC6210 Series

## ■ ELECTRICAL CHARACTERISTICS (Continued)

● Dropout Voltage, Supply Current, CE 'H/L' Level Current Chart

SETTING OUTPUT VOLTAGE	OUTPUT VOLTAGE		E-1		E-2		E-3		E-4	E-5
			DROPOUT VOLTAGE 1		DROPOUT VOLTAGE 2		SUPPLY CURRENT		CE <sup>H</sup> LEVEL CURRENT	CE <sup>L</sup> LEVEL CURRENT
(V)	(V)		(mV)		(mV)		(μA)		(μA)	(μA)
V <sub>OUT(T)</sub>	V <sub>OUT</sub>		V <sub>dif1</sub>		V <sub>dif2</sub>		I <sub>DD</sub>		I <sub>ENH</sub>	I <sub>EL</sub>
	MIN.	MAX.	TYP.	MAX.	TYP.	MAX.	TYP.	MAX.	TYP.	MAX.
3.00	2.940	3.060	15.0	23.0	50.0	75.0	43.5	-	12.5	- 12.5
3.05	2.989	3.111								
3.10	3.038	3.162								
3.15	3.087	3.213								
3.20	3.136	3.264								
3.25	3.185	3.315								
3.30	3.234	3.366								
3.35	3.283	3.417								
3.40	3.332	3.468								
3.45	3.381	3.519								
3.50	3.430	3.570								
3.55	3.479	3.621								
3.60	3.528	3.672								
3.65	3.577	3.723								
3.70	3.626	3.774								
3.75	3.675	3.825								
3.80	3.724	3.876								
3.85	3.773	3.927								
3.90	3.882	3.978								
3.95	3.871	4.029								
4.00	3.920	4.080								
4.05	3.969	4.131								
4.10	4.018	4.182								
4.15	4.067	4.233								
4.20	4.116	4.284								
4.25	4.165	4.335								
4.30	4.214	4.386								
4.35	4.263	4.437								
4.40	4.312	4.488								
4.45	4.361	4.539								
4.50	4.410	4.590								
4.55	4.459	4.641								
4.60	4.508	4.692								
4.65	4.557	4.743								
4.70	4.606	4.794								
4.75	4.655	4.845								
4.80	4.704	4.896								
4.85	4.753	4.947								
4.90	4.802	4.998								
4.95	4.851	5.049								
5.00	4.900	5.100								



■ TEST CIRCUITS

● Circuit ①

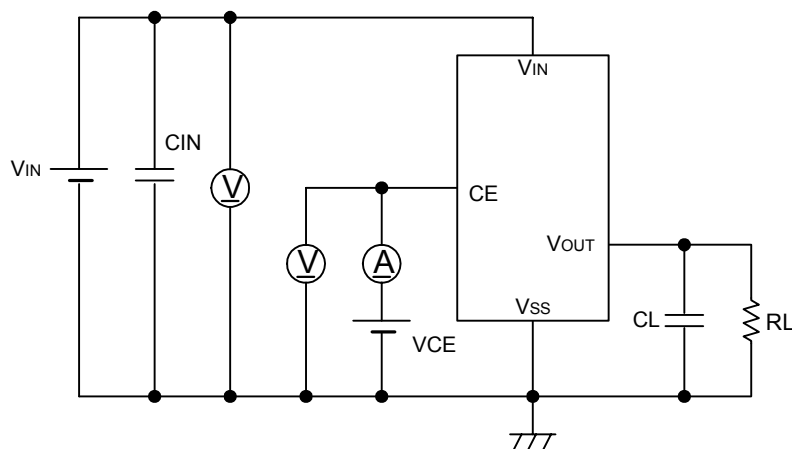

● Circuit ②

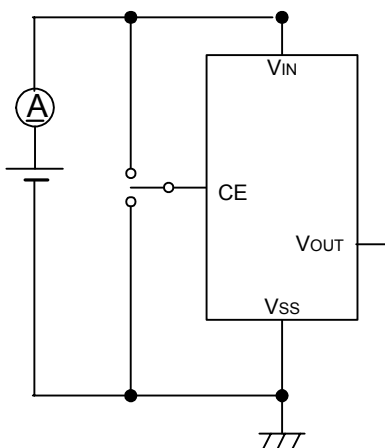

● Circuit ③

$V_{IN} = \{V_{OUT} + 1.0V\}V_{DC} + 0.5V_{p-pAC}$   
 $V_{OUT} \geq 4.75V$   
 $V_{IN} = 5.75V_{DC} + 0.5V_{p-pAC}$

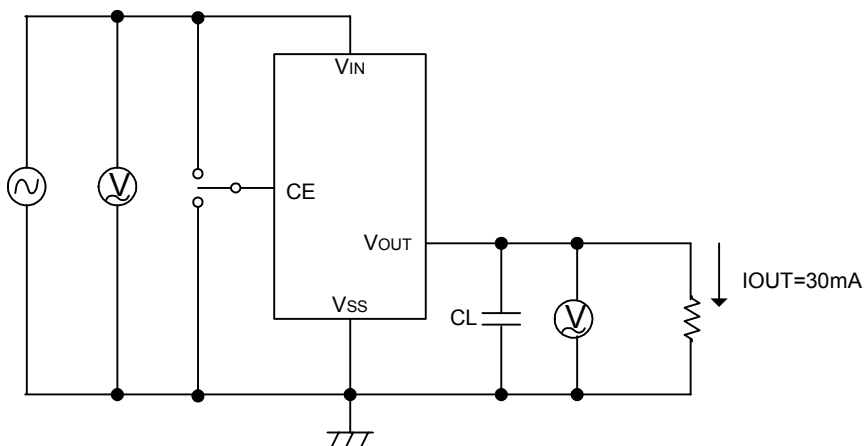

● Output Capacitor Corresponding Chart

VR OUTPUT VOLTAGE	0.8V~1.45V	1.5V ~ 1.75V	1.8V ~ 5.0V
CL	More Than 6.8 $\mu$ F	More Than 4.7 $\mu$ F	More Than 1.0 $\mu$ F

## ■ OPERATIONAL EXPLANATION

### <Output Voltage Regulator Control>

The voltage, divided by resistors R1 & R2, which are connected to the VOUT pin is compared with the internal reference voltage by the error amplifier. The P-channel MOSFET, which is connected to the VOUT pin, is then driven by the subsequent output signal. The output voltage at the VOUT pin is controlled & stabilized by negative feedback. The constant current limit circuit and short circuit protection operate in relation to the level of output current.

### <Low ESR Capacitor>

With the XC6210 series regulator, a stable output voltage is achievable even if low ESR capacitors are used, as a phase compensation circuit is built-in to the regulator. In order to ensure the effectiveness of the phase compensation, we suggest that an output capacitor (CL) be connected as close as possible, between the output pin (VOUT) and the VSS pin. Please use an output capacitor (CL) with a capacitance, based on the chart below. We also suggest an input capacitor (CIN) of 1 $\mu$ F: this should be connected between VIN and VSS in order to stabilize input power source.

Output Capacitor Corresponding Chart

VOUT	0.8V ~ 1.45V	1.5V ~ 1.75V	1.8V ~ 5.0V
CL	More Than 6.8 $\mu$ F	More Than 4.7 $\mu$ F	More Than 1.0 $\mu$ F

### <Current Limiter, Short-Circuit Protection>

The XC6210 series regulator offers a combination of current limit and circuit protection by means of a built-in fixed current limiter circuit and a foldback circuit. When the load current reaches the current limit level, the fixed current limiter circuit operates and output voltage drops. As a result of this drop in output voltage, the foldback circuit operates, the output voltage drops further and output current decreases. When the output pin is shorted, a current of about 50mA flows.

### <CE Pin>

The IC's internal regulator circuitry can be shut down via the signal from the CE pin with the XC6210 series. In shutdown mode, output at the VOUT pin will be pulled down to the VSS level via R1 & R2. Options are available for the CE pin logic (See the product classification). Note that as the XC6210B types are 'High Active / No Pull-Down', operations will become unstable with the CE pin open. Although the CE pin is equal to an inverter input with CMOS hysteresis, with either the pull-up or pull-down options, the CE pin input current will increase when the IC is in operation. We suggest that you use this IC with either a VIN voltage or a VSS voltage input at the CE pin. If this IC is used with the correct specifications for the CE pin, the IC will operate normally. However, supply current may increase as a result of through current in the IC's internal circuitry if a voltage other than VIN or VSS is applied.

## ■ NOTES ON USE

1. Please use this IC within the stated absolute maximum ratings. The IC is liable to malfunction should the ratings be exceeded.
2. Where wiring impedance is high, operations may become unstable due to noise and/or phase lag depending on output current. Please strengthen VIN and VSS wiring in particular.
3. Please wire the input capacitor (CIN) and the output capacitor (CL) as close to the IC as possible. Should rapid input fluctuation or load fluctuation occur, please increase the capacitor value such as CIN or CL to stabilize the operation.