



High Efficiency 10 LED Boost Converter

FEATURES

- Drives High Voltage LED strings (38V)
- Up to 87% Efficiency
- Low Quiescent Ground Current 0.6mA
- Adjustable Output Current
- 1MHz Fixed Frequency Low noise Operation
- Soft start “in-rush” current limiting
- Shutdown current less than 1µA
- Open LED Overvoltage Protection
- Automatic Shutdown at 1.9V (UVLO)
- Thermal overload protection
- Thin SOT23 5-Lead (1mm max height)

APPLICATIONS

- GPS Navigation Systems
- Portable Media Players
- Handheld Devices, Digital Cameras
- Portable Game Machines

ORDERING INFORMATION

Part Number	Package	Quantity per Reel	Package Marking
CAT4238TD-GT3	TSOT23-5 Green*	3000	MU

* NiPdAu Plated Finish

For Ordering Information details, see page 13.

PIN CONFIGURATION

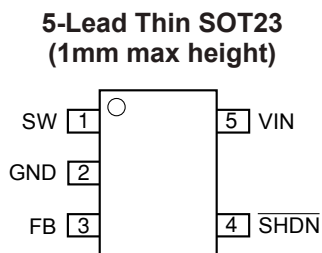

DESCRIPTION

The CAT4238 is a DC/DC step-up converter that delivers an accurate constant current ideal for driving LEDs. Operation at a fixed switching frequency of 1MHz allows the device to be used with small value external ceramic capacitors and inductor. LEDs connected in series are driven with a regulated current set by the external resistor R1. LED currents up to 40mA can be supported over a wide range of input supply voltages up to 5.5V, making the device ideal for battery-powered applications. The CAT4238 high-voltage output stage is perfect for driving mid-size and large panel displays containing up to ten white LEDs in series.

LED dimming can be done by using a DC voltage, a logic signal, or a pulse width modulation (PWM) signal. The shutdown input pin allows the device to be placed in power-down mode with “zero” quiescent current.

In addition to thermal protection and overload current limiting, the device also enters a very low power operating mode during “Open LED” fault conditions. The device is housed in a low profile (1mm max height) 5-lead thin SOT23 package for space critical applications.

TYPICAL APPLICATION CIRCUIT

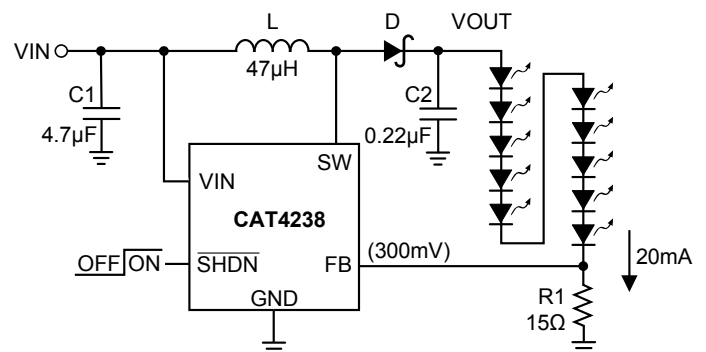

L: Sumida CDC5D23B-470

D: Central CMDSH05-4

C2: Taiyo Yuden UMK212BJ224 (rated 50V)

ABSOLUTE MAXIMUM RATINGS

Parameters	Ratings	Units
V _{IN} , FB voltage	-0.3 to +7	V
$\overline{\text{SHDN}}$ voltage	-0.3 to +7	V
SW voltage	-0.3 to 45	V
Storage Temperature Range	-65 to +160	°C
Junction Temperature Range	-40 to +125	°C
Lead Temperature	300	°C

RECOMMENDED OPERATING CONDITIONS

Typical application circuit with external components are shown on page 1.

Parameters	Range	Units
V _{IN}	up to 5.5	V
SW pin voltage	0 to 38	V
Ambient Temperature Range	-40 to +85	°C

DC ELECTRICAL CHARACTERISTICS

V_{IN} = 3.6V, ambient temperature of 25°C (over recommended operating conditions unless specified otherwise).

Symbol	Parameter	Test Conditions	Min	Typ	Max	Units
I _Q	Operating Current	V _{FB} = 0.2V V _{FB} = 0.4V (not switching)		0.6 0.1	1.5 0.6	mA
I _{SD}	Shutdown Current	V _{SHDN} = 0V		0.1	1	µA
V _{FB}	FB Pin Voltage	10 LEDs with I _{LED} = 20mA	285	300	315	mV
I _{FB}	FB pin input leakage				1	µA
I _{LED}	Programmed LED Current	R1 = 10Ω R1 = 15Ω R1 = 20Ω	28.5 19 14.25	30 20 15	31.5 21 15.75	mA
V _{IH} V _{IL}	$\overline{\text{SHDN}}$ Logic High $\overline{\text{SHDN}}$ Logic Low	Enable Threshold Level Shutdown Threshold Level		0.8 0.7	1.5	V V
F _{SW}	Switching Frequency		0.8	1.0	1.3	MHz
DC	Maximum Duty Cycle	V _{IN} = 3V		92		%
I _{LIM}	Switch Current Limit		350	450	600	mA
R _{SW}	Switch "On" Resistance	I _{SW} = 100mA		1.0	2.0	Ω
I _{LEAK}	Switch Leakage Current	Switch Off, V _{SW} = 5V		1	5	µA
	Thermal Shutdown			150		°C
	Thermal Hysteresis			20		°C
V _{UVLO}	Undervoltage Lockout (UVLO) Threshold			1.9		V
V _{OV-SW}	Overshoot Detection Threshold			40		V
V _{OCL}	Output Voltage Clamp	"Open LED"		42		V

PIN DESCRIPTION

VIN is the supply input for the internal logic. The device is compatible with supply voltages down to 2.8V and up to 5.5V. It is recommended that a small bypass ceramic capacitor (4.7µF) be placed between the VIN and GND pins near the device. If the supply voltage drops below 1.9V, the device stops switching.

SHDN is the shutdown logic input. When the pin is tied to a voltage lower than 0.4V, the device is in shutdown mode, drawing nearly zero current. When the pin is connected to a voltage higher than 1.5V, the device is enabled.

GND is the ground reference pin. This pin should be connected directly to the ground plane on the PCB.

SW pin is connected to the drain of the internal CMOS power switch of the boost converter. The inductor and the Schottky diode anode should be connected to the SW pin. Traces going to the SW pin should be as short as possible with minimum loop area. An over-voltage detection circuit is connected to the SW pin. When the voltage reaches 40V, the device enters a low power operating mode preventing the SW voltage from exceeding the maximum rating.

FB feedback pin is regulated at 0.3V. A resistor connected between the FB pin and ground sets the LED current according to the formula:

$$I_{LED} = 0.3V/R1$$

The lower LED cathode is connected to the FB pin.

Pin #	Name	Function
1	SW	Switch pin. This is the drain of the internal power switch.
2	GND	Ground pin. Connect the pin to the ground plane.
3	FB	Feedback pin. Connect to the last LED cathode.
4	SHDN	Shutdown pin (Logic Low). Set high to enable the driver.
5	VIN	Power Supply input.

BLOCK DIAGRAM

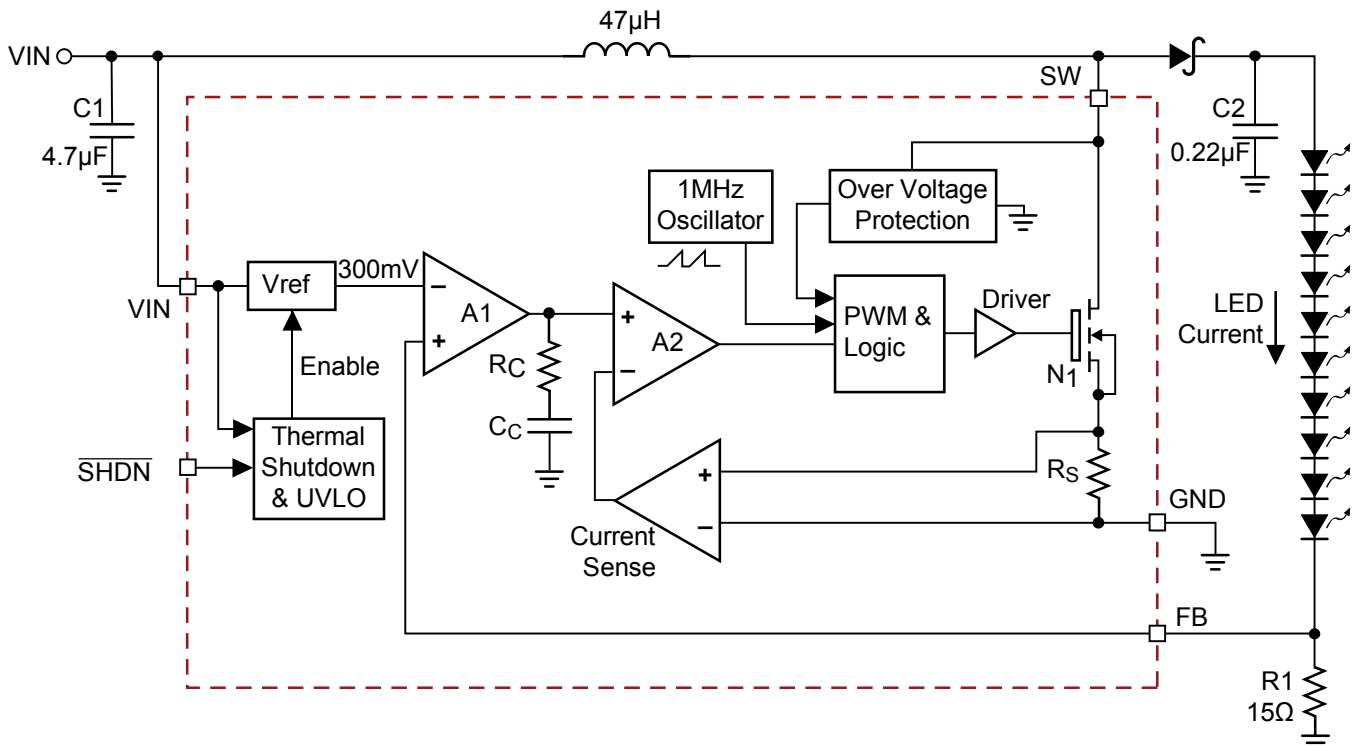

CAT4238

DEVICE OPERATION

The CAT4238 is a fixed frequency (1MHz), low noise, inductive boost converter that provides a constant current with excellent line and load regulation. The device uses a high-voltage CMOS power switch between the SW pin and ground to energize the inductor. When the switch is turned off, the stored energy in the inductor is released into the load via the Schottky diode.

The on/off duty cycle of the power switch is internally adjusted and controlled to maintain a constant regulated voltage of 0.3V across the feedback resistor connected to the feedback pin (FB). The value of the resistor sets the LED current accordingly ($0.3V/R1$).

During the initial power-up stage, the duty cycle of the internal power switch is limited to prevent excessive in-rush currents and thereby provide a “soft-start” mode of operation.

While operating from a Li-Ion battery, the device can deliver 20mA of load current into a string of up to 10 white LEDs. For higher input voltages, the LED current can be increased.

In the event of an “Open LED” fault condition, where the feedback control loop becomes open, the output voltage will continue to increase. Once this voltage exceeds 40V, an internal protection circuit will become active and place the device into a very low power safe operating mode where only a small amount of power is transferred to the output. This is achieved by pulsing the switch once every 6 μ s and keeping it on for about 1 μ s.

Thermal overload protection circuitry has been included to prevent the device from operating at unsafe junction temperatures above 150°C. In the event of a thermal overload condition the device will automatically shutdown and wait till the junction temperatures cools to 130°C before normal operation is resumed.

Light Load Operation

Under light load condition (under 2mA) and with input voltage above 5.0V, the CAT4238 driving 10 LEDs, the driver starts pulse skipping. Although the LED current remains well regulated, some lower frequency ripple may appear.

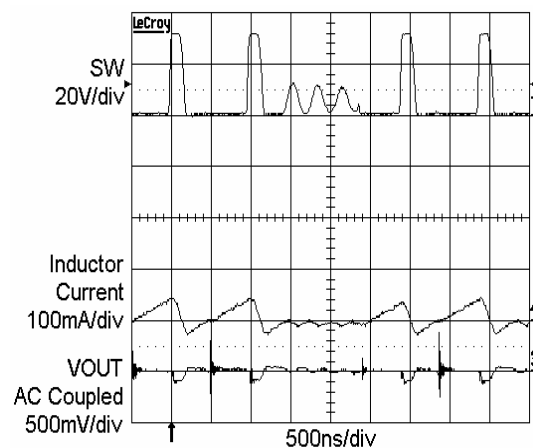

Switching Waveform VIN = 5.0V, I_{LED} = 1.5mA

TYPICAL CHARACTERISTICS

$V_{IN} = 3.6V$, $C_{IN} = 4.7\mu F$, $C_{OUT} = 0.22\mu F$, $L = 47\mu H$ with 10 LEDs at 20mA, $T_{AMB} = 25^{\circ}C$, unless otherwise specified.

Quiescent Current vs. VIN (Not Switching)

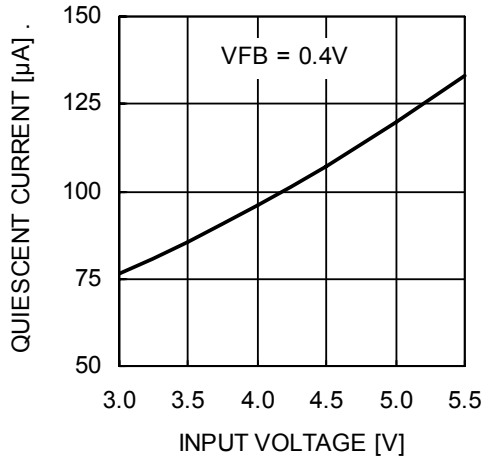

Quiescent Current vs. VIN (Switching)

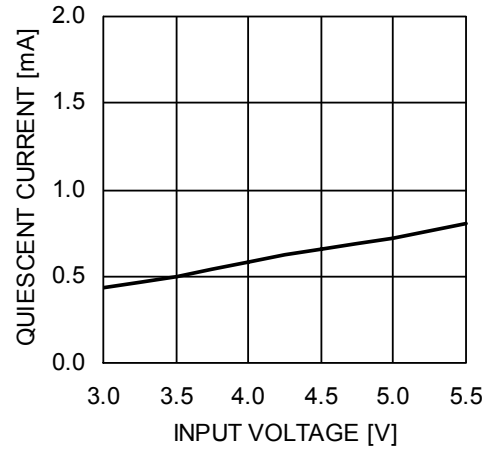

FB pin voltage vs. Temperature

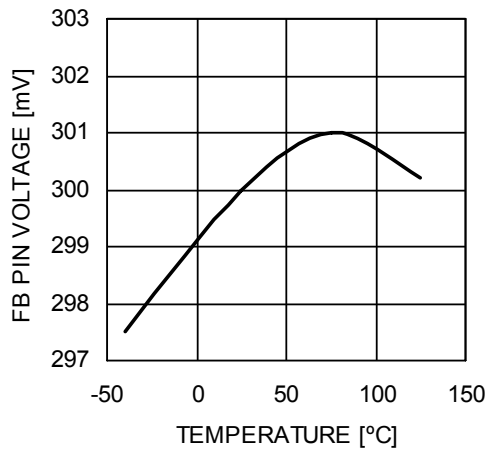

FB Pin Voltage vs. Output Current

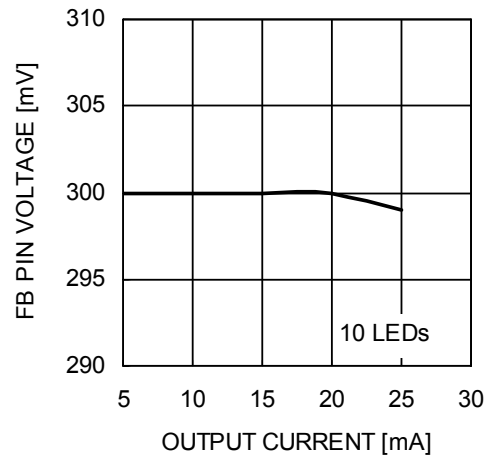

Switching Frequency vs. Supply Voltage

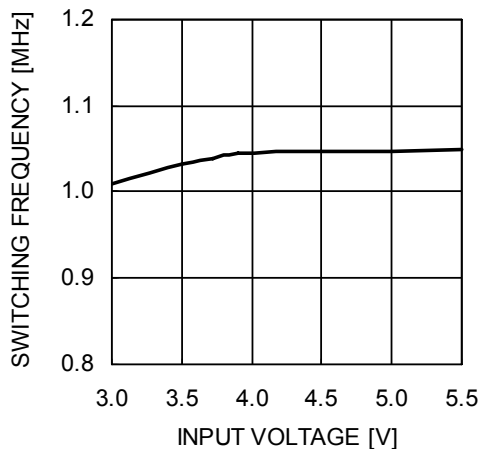

Switching Waveforms

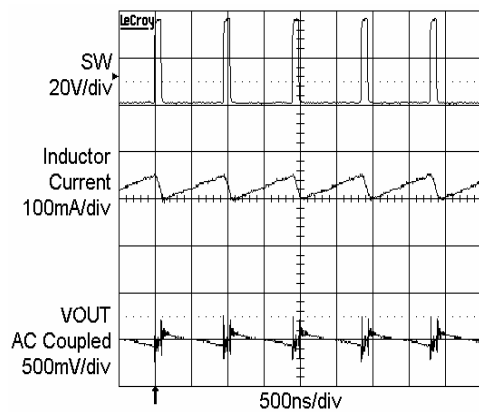

CAT4238

TYPICAL CHARACTERISTICS

$V_{IN} = 3.6V$, $C_{IN} = 4.7\mu F$, $C_{OUT} = 0.22\mu F$, $L = 47\mu H$ with 10 LEDs at 20mA, $T_{AMB} = 25^{\circ}C$, unless otherwise specified.

LED Current vs. Input Voltage

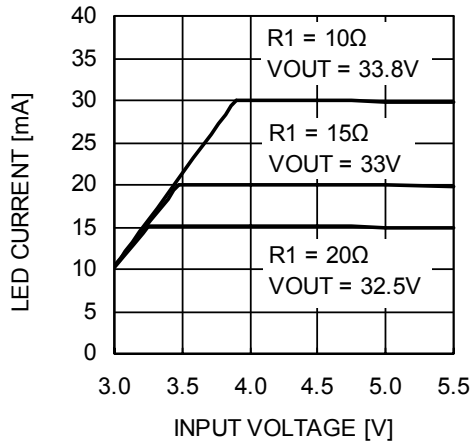

LED Current Regulation (10mA)

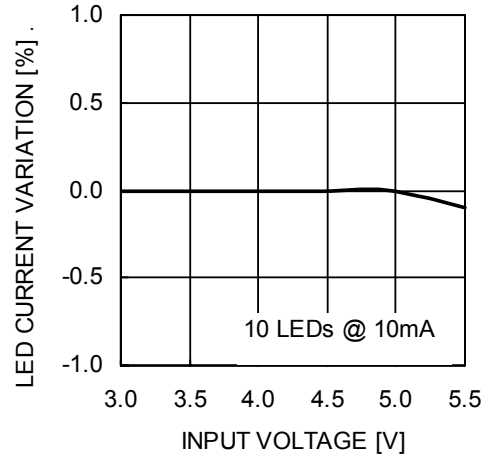

Efficiency vs. Load Current (10 LEDs)

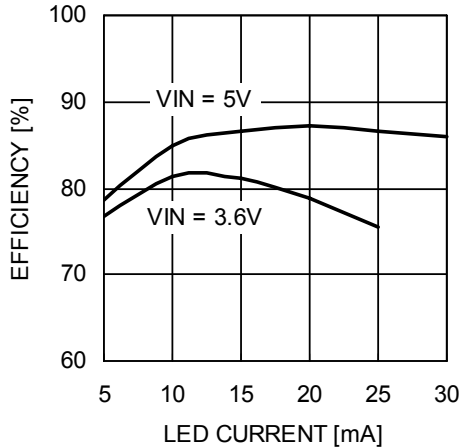

Efficiency vs. Input Voltage (10 LEDs)

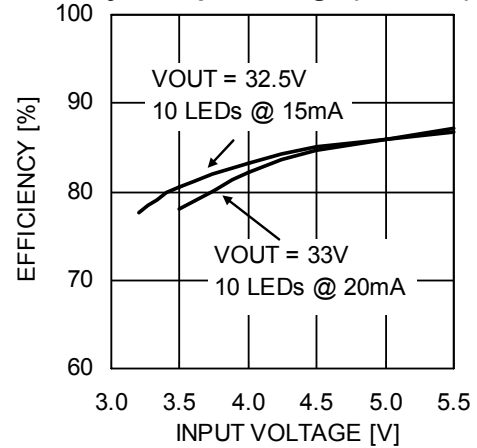

Power-up with 10 LEDs at 20mA

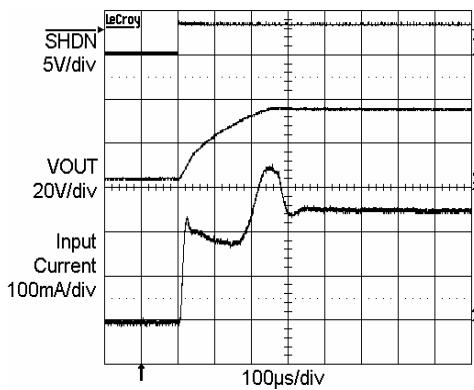

Switch ON Resistance vs. Input Voltage

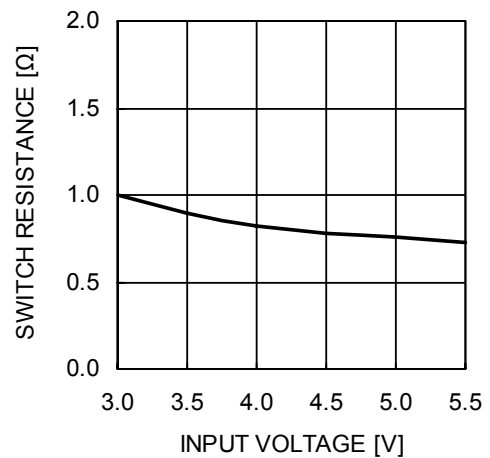

TYPICAL CHARACTERISTICS

$V_{IN} = 3.6V$, $C_{IN} = 4.7\mu F$, $C_{OUT} = 0.22\mu F$, $L = 47\mu H$ with 10 LEDs at 20mA, $T_{AMB} = 25^{\circ}C$, unless otherwise specified.

Maximum Output Current vs. Input Voltage

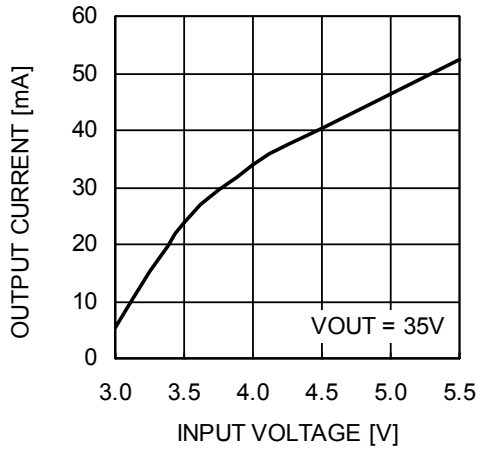

Shutdown Voltage vs. Input Voltage

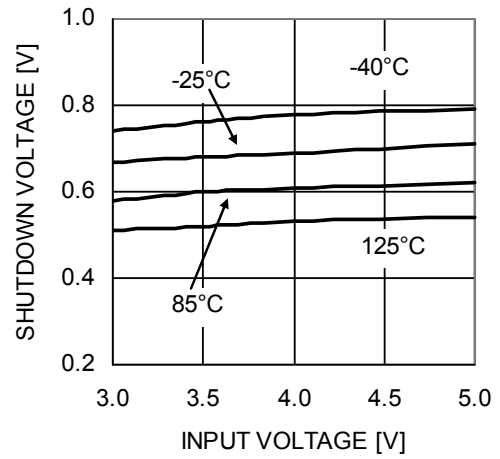

APPLICATION INFORMATION

External Component Selection

Capacitors

The CAT4238 only requires small ceramic capacitors of 4.7 μ F on the input and 0.22 μ F on the output. Under normal condition, a 4.7 μ F input capacitor is sufficient. For applications with higher output power, a larger input capacitor of 10 μ F may be appropriate. X5R and X7R capacitor types are ideal due to their stability across temperature range.

Inductor

A 47 μ H inductor is recommended for most of the CAT4238 applications. In cases where the efficiency is critical, inductances with lower series resistance are preferred. Inductors with current rating of 300mA or higher are recommended for most applications. Sumida CDC5D23B-470 47 μ H inductor has a rated current of 490mA and a series resistance (D.C.R.) of 420m Ω typical.

Schottky Diode

The current rating of the Schottky diode must exceed the peak current flowing through it. The Schottky diode performance is rated in terms of its forward

voltage at a given current. In order to achieve the best efficiency, this forward voltage should be as low as possible. The response time is also critical since the driver is operating at 1MHz. Central Semiconductor Schottky diode CMDSH05-4 (500mA rated) is recommended for most applications.

LED Current Setting

The LED current is set by the external resistor R1 connected between the feedback pin (FB) and ground. The formula below gives the relationship between the resistor and the current:

$$R1 = 0.3V/LED \text{ current}$$

LED current (mA)	R1 (Ω)
5	60
10	30
15	20
20	15
25	12
30	10

Table 1. Resistor R1 and LED current

OPEN LED PROTECTION

In the event of an “Open LED” fault condition, the CAT4238 will continue to boost the output voltage with maximum power until the output voltage reaches approximately 40V. Once the output exceeds this level, the internal circuitry immediately places the device into a very low power mode where the total input power is limited to about 6mW (about 1.6mA

input current with a 3.6V supply). The SW pin clamps at a voltage below its maximum rating of 60V. There is no need to use an external zener diode between Vout and the FB pin. A 50V rated C2 capacitor is required to prevent any overvoltage damage in the open LED condition.

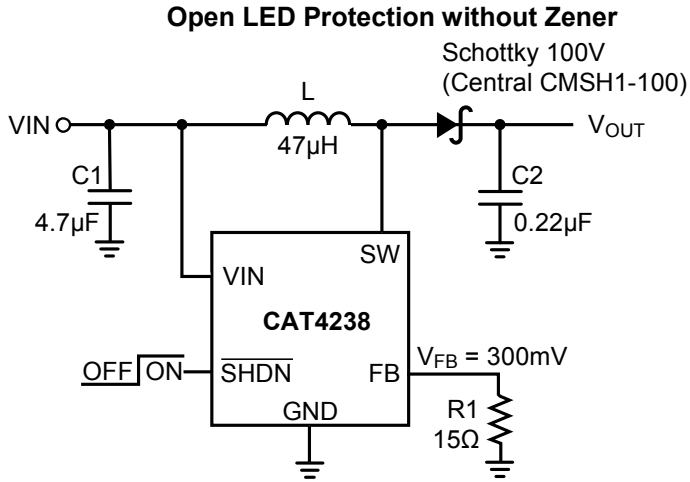

Open LED Switching Waveforms without Zener

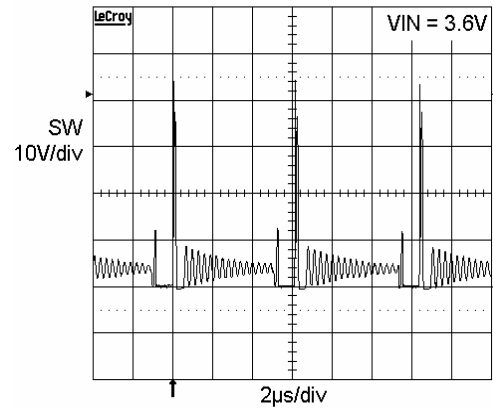

Open LED Supply Current vs. VIN without Zener

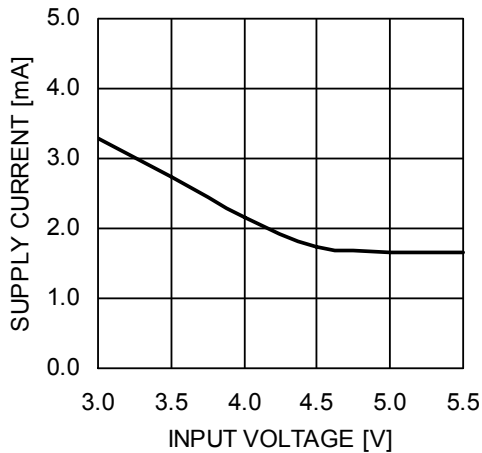

Open LED Output Voltage vs. VIN without Zener

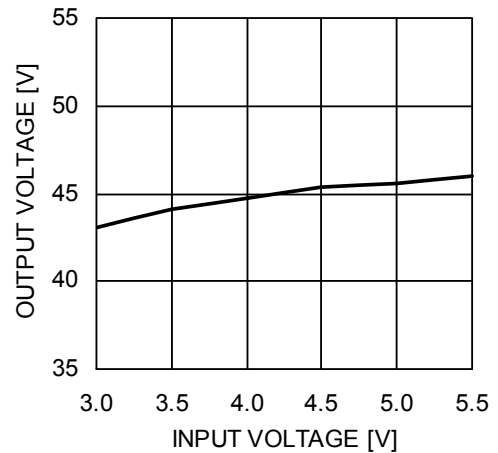

DIMMING CONTROL

There are several methods available to control the LED brightness.

PWM signal on the $\overline{\text{SHDN}}$ Pin

LED brightness dimming can be done by applying a PWM signal to the $\overline{\text{SHDN}}$ input. The LED current is repetitively turned on and off, so that the average current is proportional to the duty cycle. A 100% duty cycle, with $\overline{\text{SHDN}}$ always high, corresponds to the LEDs at nominal current. Figure 1 shows a 1kHz signal with a 50% duty cycle applied to the $\overline{\text{SHDN}}$ pin. The recommended PWM frequency range is from 100Hz to 2kHz.

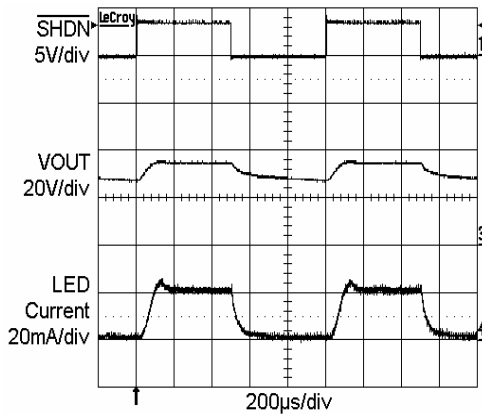

Figure 1. Switching Waveform with 1kHz PWM on $\overline{\text{SHDN}}$

Filtered PWM Signal

A filtered PWM signal used as a variable DC voltage can control the LED current. Figure 2 shows the PWM control circuitry connected to the CAT4238 FB pin. The PWM signal has a voltage swing of 0V to 2.5V. The LED current can be dimmed within a range from 0mA to 20mA. The PWM signal frequency can vary from very low frequency up to 100kHz.

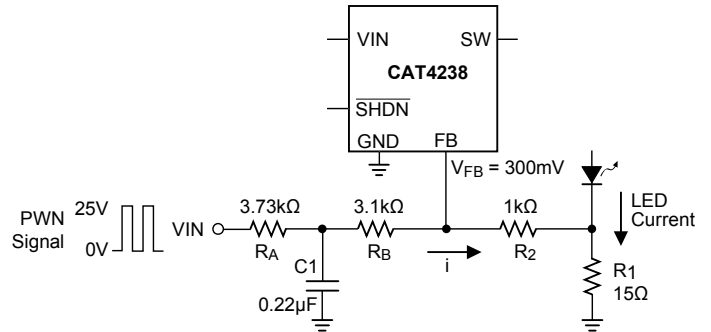
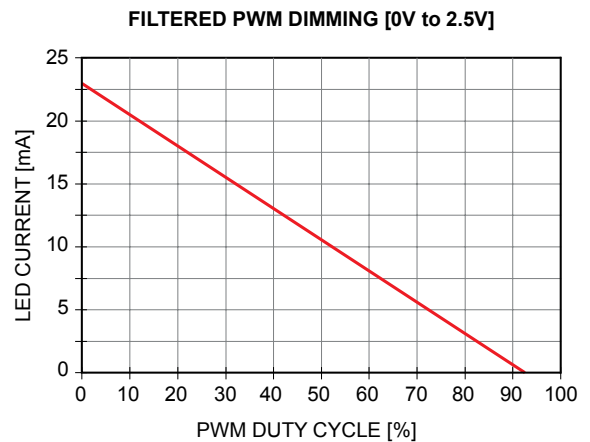

Figure 2. Circuit for Filtered PWM Signal

A PWM signal at 0V DC, or a 0% duty cycle, results in a max LED current of about 22mA. A PWM signal with a 93% duty cycle or more, results in an LED current of 0mA.



BOARD LAYOUT

The CAT4238 is a high-frequency switching regulator. The traces that carry the high-frequency switching current have to be carefully laid out on the board in order to minimize EMI, ripple and noise in general. The thicker lines on Figure 3 show the switching current path. All these traces have to be short and wide enough to minimize the parasitic inductance and resistance. The loop shown on Figure 3 corresponds to the current path when the CAT4238 internal switch is closed. On Figure 4 is shown the current loop, when the CAT4238 switch is open. Both loop areas should be as small as possible.

Capacitor C1 has to be placed as close as possible to the VIN pin and GND. The capacitor C2 has to be connected separately to the top LED anode. A ground plane under the CAT4238 allows for direct connection of the capacitors to ground. The resistor R1 must be connected directly to the GND pin of the CAT4238 and not shared with the switching current loops and any other components.

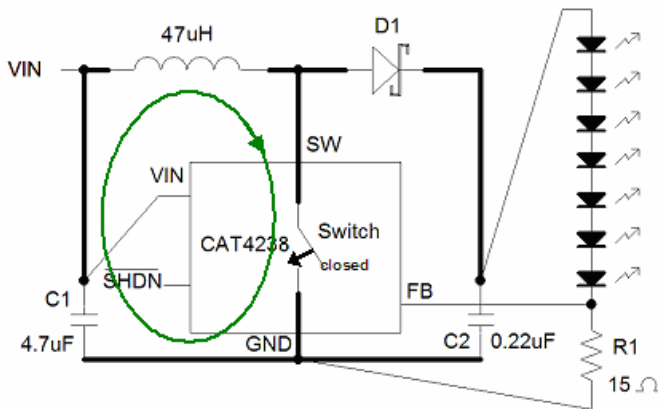

Figure 3. Closed-switch Current Loop

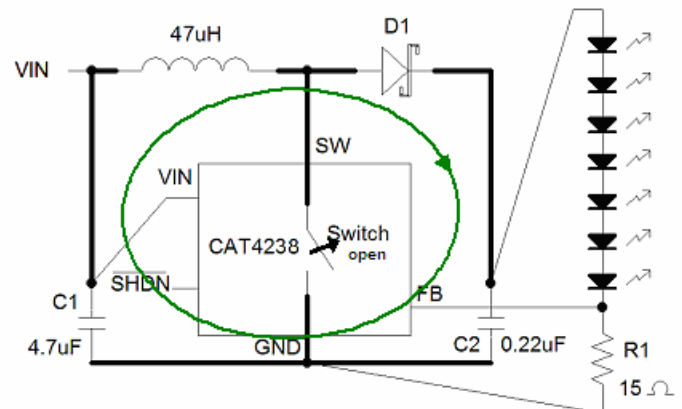

Figure 4. Open-switch Current Loop

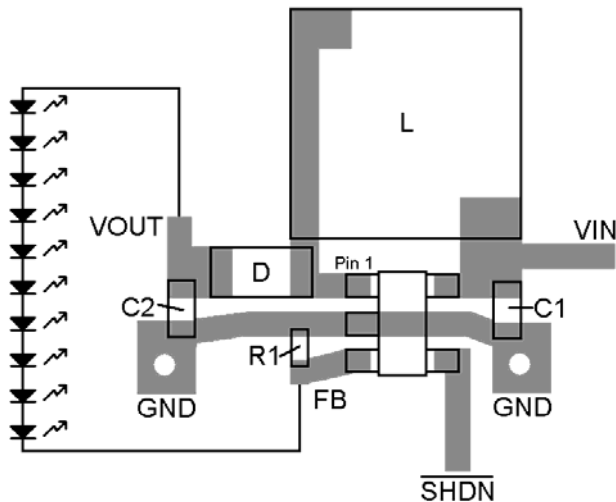
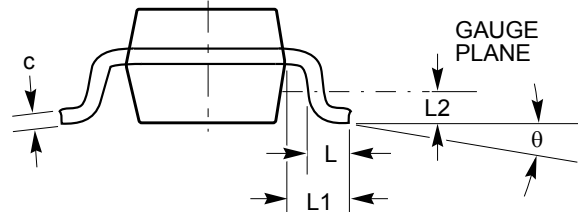
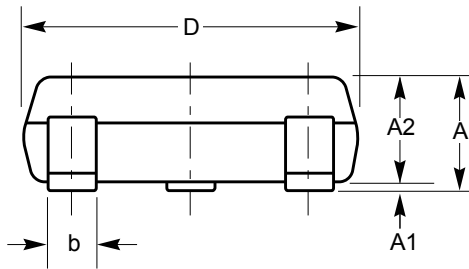
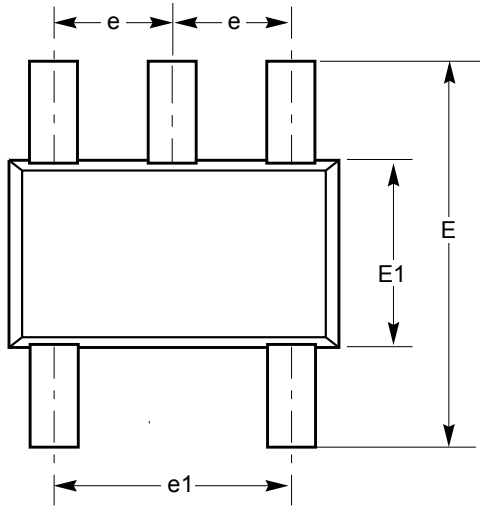

Figure 5. Recommended PCB Layout

CAT4238

PACKAGE OUTLINES

5-LEAD SOT-23



SYMBOL	MIN	NOM	MAX
A	—	—	1.0
A1	0.01	0.05	0.1
A2	0.80	0.87	0.9
b	0.30	—	0.45
c	0.12	0.15	0.20
D	2.90 BSC		
E	2.80 BSC		
E1	1.60 BSC		
e	1.95 BSC		
e1	1.90 BSC		
L	0.30	0.40	0.50
L1	0.60 REF		
L2	0.25 BSC		
q	0°		8°

Notes:

- (1) All dimensions are in millimeters, angles in degrees.
- (2) Refer JEDEC MO-193.

EXAMPLE OF ORDERING INFORMATION

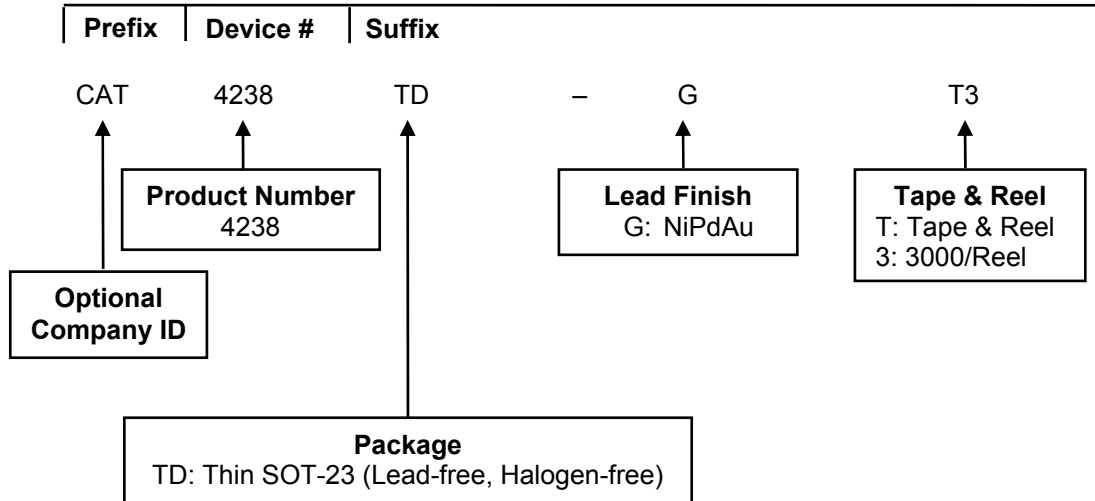

Notes:

- (1) All packages are RoHS-compliant (Lead-free, Halogen-free).
- (2) The standard lead finish is NiPdAu.
- (3) The device used in the above example is a CAT4238-GT3 (TSOT-23, NiPdAu, Tape & Reel).
- (4) For additional package and temperature options, please contact your nearest Catalyst Semiconductor Sales office.

REVISION HISTORY

Date	Rev.	Reason
06/14/2006	A	Initial Issue

Copyrights, Trademarks and Patents

Trademarks and registered trademarks of Catalyst Semiconductor include each of the following:

DPP [™] AE2 [™]

Catalyst Semiconductor has been issued U.S. and foreign patents and has patent applications pending that protect its products.

CATALYST SEMICONDUCTOR MAKES NO WARRANTY, REPRESENTATION OR GUARANTEE, EXPRESS OR IMPLIED, REGARDING THE SUITABILITY OF ITS PRODUCTS FOR ANY PARTICULAR PURPOSE, NOR THAT THE USE OF ITS PRODUCTS WILL NOT INFRINGE ITS INTELLECTUAL PROPERTY RIGHTS OR THE RIGHTS OF THIRD PARTIES WITH RESPECT TO ANY PARTICULAR USE OR APPLICATION AND SPECIFICALLY DISCLAIMS ANY AND ALL LIABILITY ARISING OUT OF ANY SUCH USE OR APPLICATION, INCLUDING BUT NOT LIMITED TO, CONSEQUENTIAL OR INCIDENTAL DAMAGES.

Catalyst Semiconductor products are not designed, intended, or authorized for use as components in systems intended for surgical implant into the body, or other applications intended to support or sustain life, or for any other application in which the failure of the Catalyst Semiconductor product could create a situation where personal injury or death may occur.

Catalyst Semiconductor reserves the right to make changes to or discontinue any product or service described herein without notice. Products with data sheets labeled "Advance Information" or "Preliminary" and other products described herein may not be in production or offered for sale.

Catalyst Semiconductor advises customers to obtain the current version of the relevant product information before placing orders. Circuit diagrams illustrate typical semiconductor applications and may not be complete.



Catalyst Semiconductor, Inc.
Corporate Headquarters
1250 Borregas Avenue
Sunnyvale, CA 94089
Phone: 408.542.1000
Fax: 408.542.1200
www.catsemi.com

Document No: 5019
Revision: A
Issue date: 06/14/06