



AME4620

■ General Description

The AME4620 analog switches feature low ON resistance, single-pole, double-throw (SPDT) with wide operating single power supply voltage range, from 2.7V to 5.5V.

AME4620 has 1Ω max ON resistance when +5V power supply is used. These products also have fast switching speeds, $t_{ON} = t_{OFF} = 50nS$ max.

AME4620 is available in SC70-6.

■ Features

- Low R_{ON}
- Wide Operation Supply Voltage: 2.7V to 5.5V
- Fast Switching Time: $t_{ON} = t_{OFF} = 50nS$ max.
- TTL-Logic Compatible
- Pin Compatible with FSA4157
- Over Thermal Protection
- Space saving in SC70-6

■ Functional Block Diagram

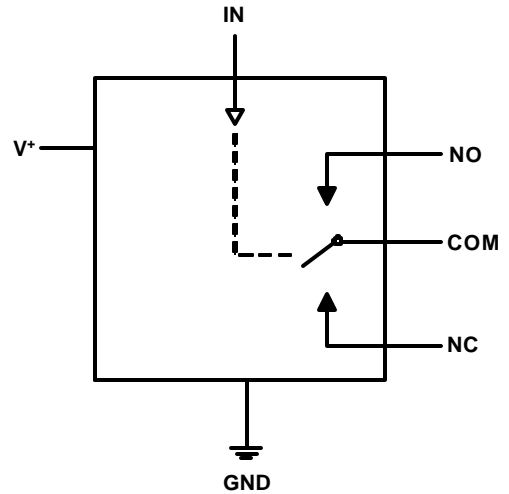

In Logic	NC	NO
0	ON	OFF
1	OFF	ON

■ Applications

- Power Routing
- Battery-Operated Equipment
- Audio and Video Signal Routing
- Low-Voltage Data-Acquisition Systems
- Communications Circuits
- PCMCIA Cards
- PC Peripherals

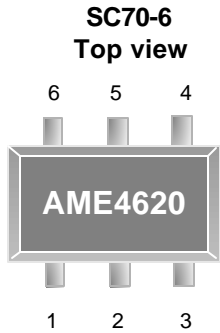
■ Pin Configuration

AME4620A

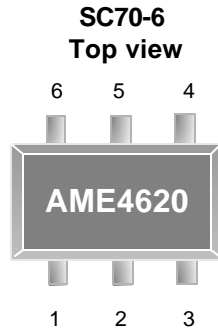
1. NO
2. GND
3. NC
4. COM
5. V+
6. IN

AME4620B

1. NC
2. GND
3. NO
4. COM
5. V+
6. IN

*** Die Attach:
Conductive Epoxy**

*** Die Attach:
Conductive Epoxy**

■ Pin Description

Pin Name	Pin Description
IN	Digital Control Input
V+	Positive Supply Voltage Input
GND	Ground
NC	Analog Switch-Normally Closed
COM	Analog Switch-Common
NO	Analog Switch-Normally Open

■ Ordering Information

Part Number	Marking*	Activity Mode	Package	Operating Temp. Range
AME4620AEIY	BCYw	Break-Before-Make	SC70-6	- 40°C to + 85°C
AME4620AEIYZ	BCYw	Break-Before-Make	SC70-6	- 40°C to + 85°C
AME4620BEIY	BCZw	Break-Before-Make	SC70-6	- 40°C to + 85°C
AME4620BEIYZ	BCZw	Break-Before-Make	SC70-6	- 40°C to + 85°C

Note: ww represents the date code and pls refer to Date Code Rule before Package Dimension.

* A line on top of the first letter represents lead free plating such as \overline{BCY}

Pls consult AME sales office or authorized Rep./Distributor for the availability of package type.



AME4620

■ Ordering Information

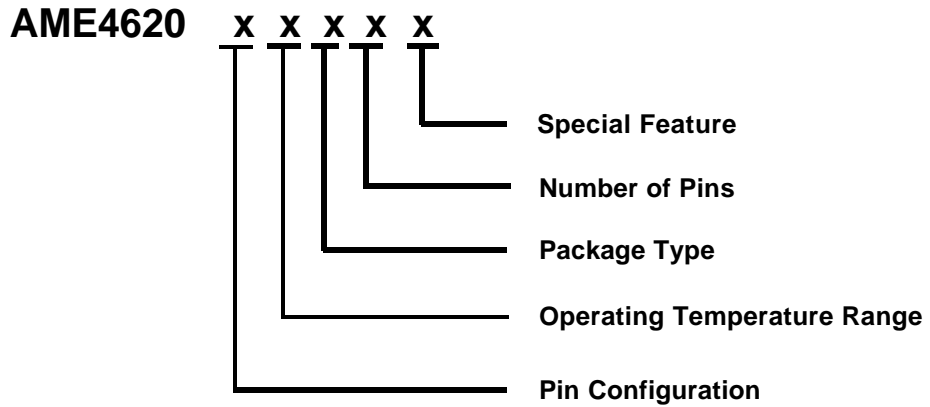

Pin Configuration	Operating Temperature Range	Package Type	Number of Pins	Special Feature
A: 1. NO 2. GND 3. NC 4. COM 5. V+ 6. IN B: 1. NC 2. GND 3. NO 4. COM 5. V+ 6. IN	E: -40°C to 85°C	I: SC70	Y: 6	Z: Lead free



■ Absolute Maximum Ratings

Parameter	Maximum	Unit
V ⁺ , IN	6	V
COM , NC , NO	Note 1	V
Continuous Current COM , NC , NO	300	mA
ESD Classification	B	

Note1: Signals on COM, NC and NO can not exceed V⁺

Caution: Stress above the listed absolute maximum rating may cause permanent damage to the device

■ Recommended Operating Conditions

Parameter	Rating	Unit
V ⁺	2.7 to 5.5	V
IN	CMOS, TTL Logic	V
Ambient Temperature Range	- 40 to + 85	°C
Junction Temperature Range	- 40 to + 125	°C

■ Thermal Information

Parameter	Package	Die Attach	Symbol	Maximum	Unit
Thermal Resistance (Junction to Ambient)	SC70-6	Conductive Epoxy	θ_{JA}	331	°C / W
Maximum Lead Temperature (10sec)				300	°C

■ Electrical Specifications

$V^+ = +5V \pm 10\%$, $GND = 0V$, $I_{NH} = 2.4V$, $I_{NL} = 0.8V$, $T_A = T_{MIN}$ to T_{MAX} , unless otherwise noted.
Typical values are at $T_A = +25^\circ C$.

Parameter	Symbol	Test Condition	Min	Typ	Max	Units
ANALOG SWITCH						
On-Resistance	R_{ON}	$V^+ = 4.5V$ $I_{COM} = 100mA$	$T_A = +25^\circ C$		1.0	Ω
			$T_A = T_{MIN}$ to T_{MAX}		1.2	
On-Resistance Match between channels	ΔR_{ON}	$V^+ = 4.5V$ $I_{COM} = 100mA$ V_{NO} or $V_{NC} = 3.5V$	$T_A = +25^\circ C$		0.12	Ω
			$T_A = T_{MIN}$ to T_{MAX}		0.15	
On-Resistance Match Flatness	R_{FLATE}	$V^+ = 4.5V$ $I_{COM} = 100mA$ V_{NO} or $V_{NC} = 0V, 1V, 2V$	$T_A = +25^\circ C$	0.15	0.2	Ω
			$T_A = T_{MIN}$ to T_{MAX}		0.2	
Switch Off-Leakage Current	$I_{NO(OFF)}$ $I_{NC(OFF)}$	$V^+ = 5.5V$ $V_{COM} = 1V, 4.5V$ V_{NC} or $V_{NO} = 4.5V$ or $1V$	$T_A = +25^\circ C$	-0.1	0.05	nA
			$T_A = T_{MIN}$ to T_{MAX}	-1.0	1.0	
DIGITAL I/O						
Input Logic High	I_{NH}	$V^+ = 5.5V$	2.4			V
Input Logic Low	I_{NL}				0.8	
Input Current Logic High or Low	I_{IH}, I_{IL}	$V_{IN} = V^+, 0V$	-1.0		1.0	μA
SWITCH DYNAMIC CHARACTERISTICS						
Turn-On Time	t_{ON}	Figure 1	$T_A = +25^\circ C$		50	ns
			$T_A = T_{MIN}$ to T_{MAX}		60	
Turn-Off Time	t_{OFF}	Figure 1	$T_A = +25^\circ C$		50	ns
			$T_A = T_{MIN}$ to T_{MAX}		60	
Break-Before-Make Delay	t_{BBM}	Figure 2	$T_A = +25^\circ C$	1	20	ns
			$T_A = T_{MIN}$ to T_{MAX}	1		
POWER SUPPLY						
Power Supply Range	V^+		$T_A = T_{MIN}$ to T_{MAX}	1.8	5.5	V
V^+ Supply Current	I^+	$V^+ = 5.5V, I_N = 0V$ or V^+	$T_A = T_{MIN}$ to T_{MAX}		10.0	μA

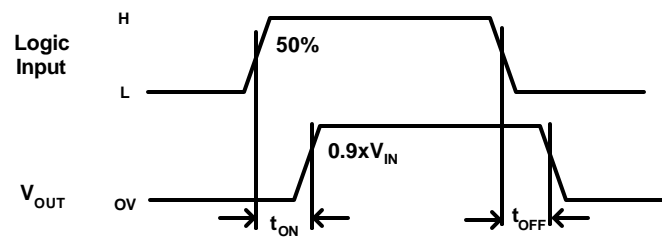
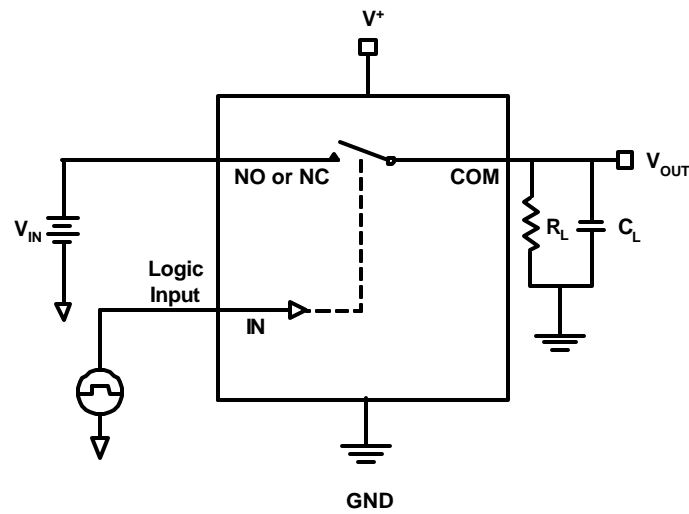
■ Timing Diagrams
Figure 1



■ Timing Diagrams

Figure 2

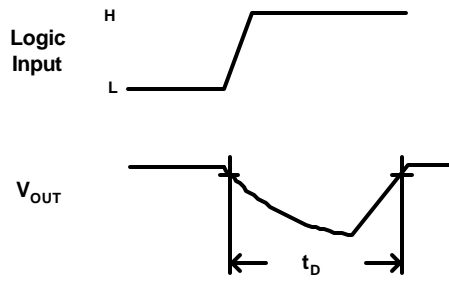
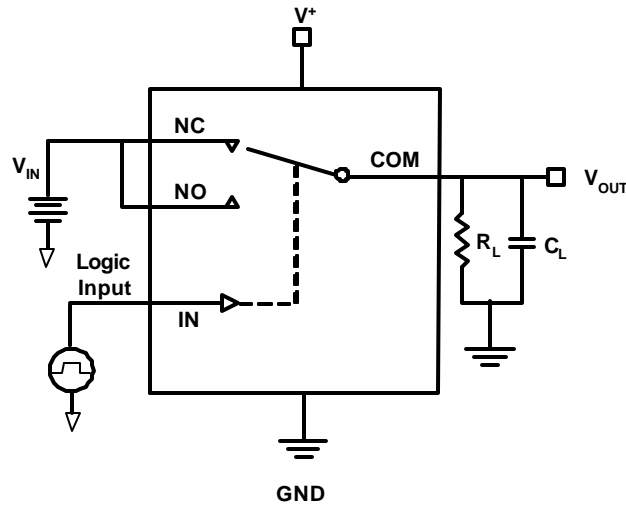



R_{on} vs. COM Voltage over Supply Voltage

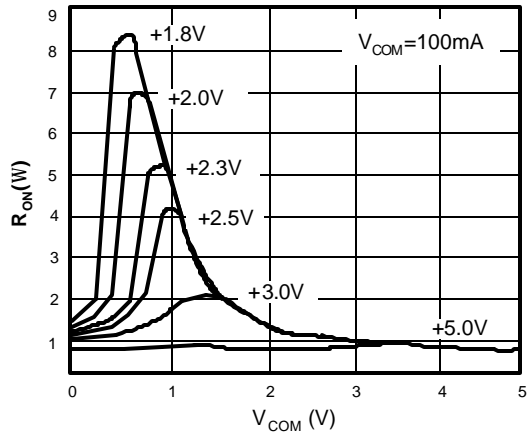

R_{on} vs. COM Voltage over Temperature

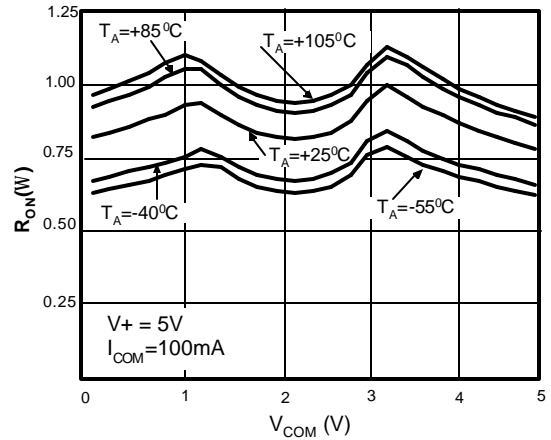

OFF Leakage vs. Temperature

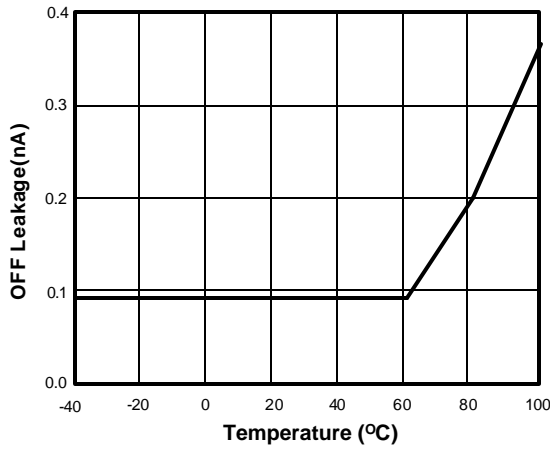

Charge Injection vs. COM Voltage

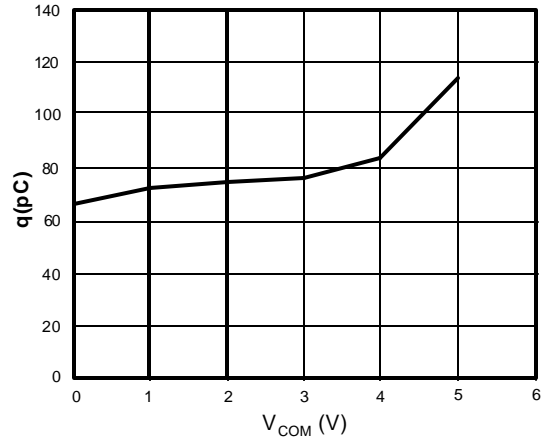

Logic Threshold Voltage vs. Supply Voltage

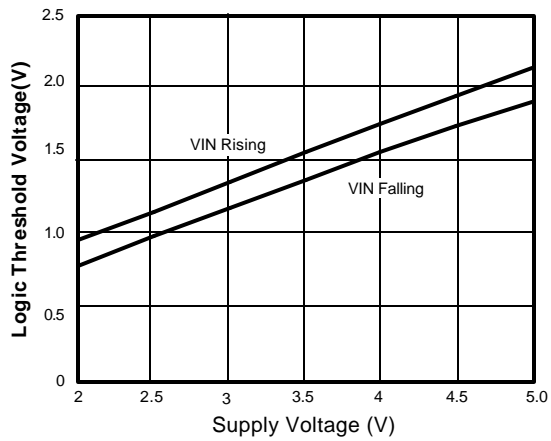

TURN-ON/OFF Times vs. Supply Voltage

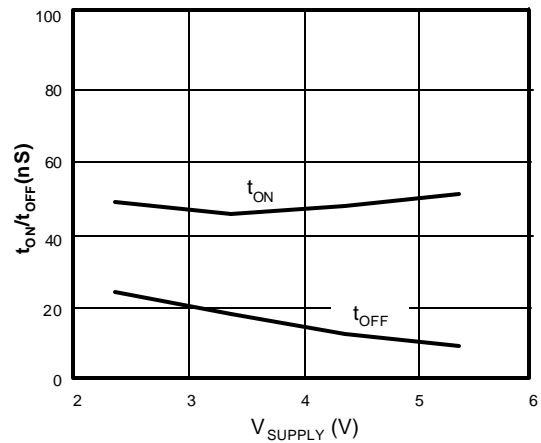



TURN-ON/OFF Times vs. Temperature

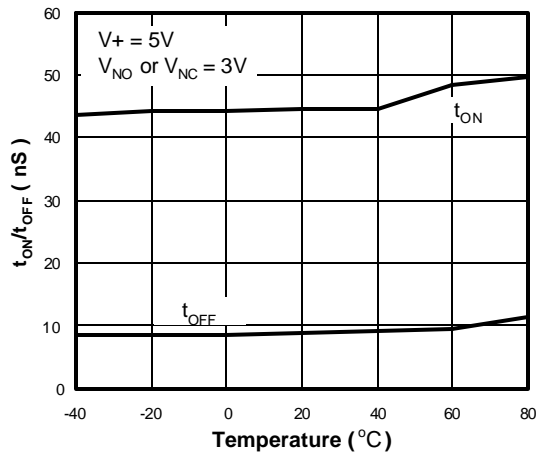

■ Date Code Rule
For SC70 Package Only

Marking			Date Code	Year
A	A	A	W	xxx0
A	A	A	<u>W</u>	xxx1
A	A	<u>A</u>	W	xxx2
A	A	<u>A</u>	<u>W</u>	xxx3
A	<u>A</u>	A	W	xxx4
A	<u>A</u>	A	<u>W</u>	xxx5
A	<u>A</u>	<u>A</u>	W	xxx6
A	<u>A</u>	<u>A</u>	<u>W</u>	xxx7
<u>A</u>	A	A	W	xxx8
<u>A</u>	A	A	<u>W</u>	xxx9

w: Work Week Code		
A: 01&02	K: 21&22	U: 41&42
B: 03&04	L: 23&24	V: 43&44
C: 05&06	M: 25&26	W: 45&46
D: 07&08	N: 27&28	X: 47&48
E: 09&10	O: 29&30	Y: 49&50
F: 11&12	P: 31&32	Z: 51&52
G: 13&14	Q: 33&34	
H: 15&16	R: 35&36	
I: 17&18	S: 37&38	
J: 19&20	T: 39&40	

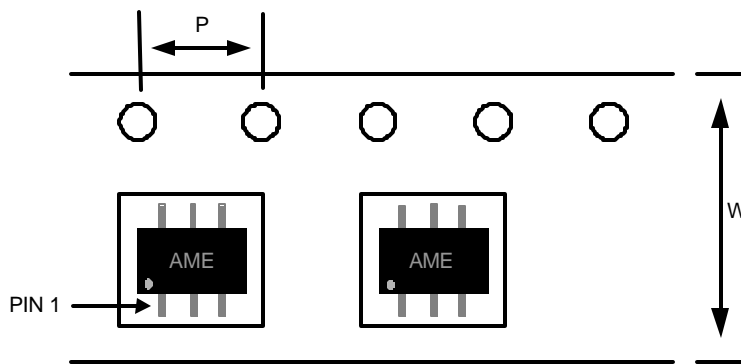
■ Tape and Reel Dimension
SC70-6

Carrier Tape, Number of Components Per Reel and Reel Size

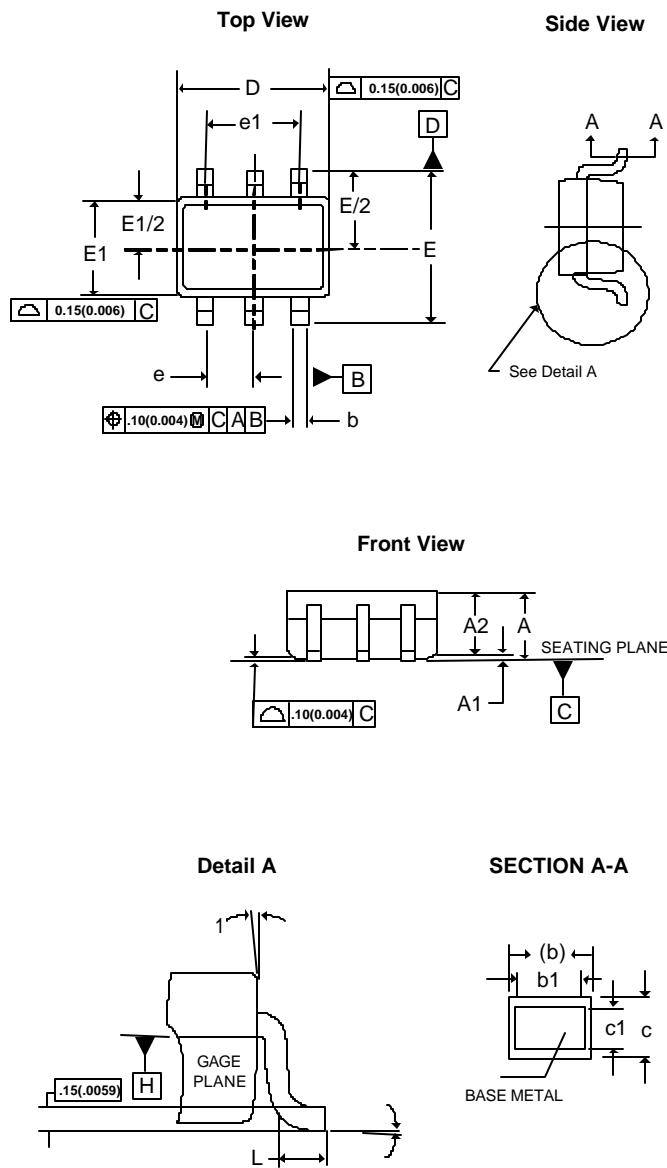
Package	Carrier Width (W)	Pitch (P)	Part Per Full Reel	Reel Size
SC-70-6L	8.0±0.1 mm	4.0±0.1 mm	3000pcs	180±1 mm

■ Package Dimension
SC70-6L

SYMBOLS	MILLIMETERS		INCHES	
	MIN	MAX	MIN	MAX
A	0.80	1.10	0.031	0.043
A1	0.00	0.10	0.000	0.004
A2	0.80	1.00	0.031	0.039
b	0.15	0.35	0.006	0.014
b1	0.15	0.25	0.006	0.010
c	0.08	0.25	0.003	0.010
c1	0.08	0.20	0.003	0.008
D	1.90	2.20	0.075	0.087
E	2.00	2.45	0.079	0.096
E1	1.15	1.35	0.045	0.053
e	0.65BSC		0.0255BSC	
e1	1.30BSC		0.0512BSC	
L	0.26	0.46	0.010	0.018
q1	0°	8°	0°	8°
q2	4°	10°	4°	10°



www.ame.com.tw
E-Mail: sales@ame.com.tw

Life Support Policy:

These products of AME, Inc. are not authorized for use as critical components in life-support devices or systems, without the express written approval of the president of AME, Inc.

AME, Inc. reserves the right to make changes in the circuitry and specifications of its devices and advises its customers to obtain the latest version of relevant information.

© AME, Inc. , November 2005

Document: 2105-DS4620-A

Corporate Headquarter

AME, Inc.

2F, 302 Rui-Guang Road, Nei-Hu District

Taipei 114, Taiwan .

Tel: 886 2 2627-8687

Fax: 886 2 2659-2989

U.S.A.(Subsidiary)

Analog Microelectronics, Inc.

3100 De La Cruz Blvd., Suite 201

Santa Clara, CA. 95054-2046

Tel : (408) 988-2388

Fax: (408) 988-2489